

重复精度  
Repeat Accuracy  
±0.02  
mm

此图仅供参考, 出货规格详见尺寸图面  
This picture for reference only, specs details according with the drawing.

最大行程  
Max Stroke 400mm

最高速度  
Max Speed 100mm/s

电机额定功率  
Rated power of motor 100W

滚珠螺杆  
Ball screw Ø10mm

型号表达方式 Ordering method

TPA-ESR-25-1002C-L200-M-FA-W-P10B-J3-C3-F

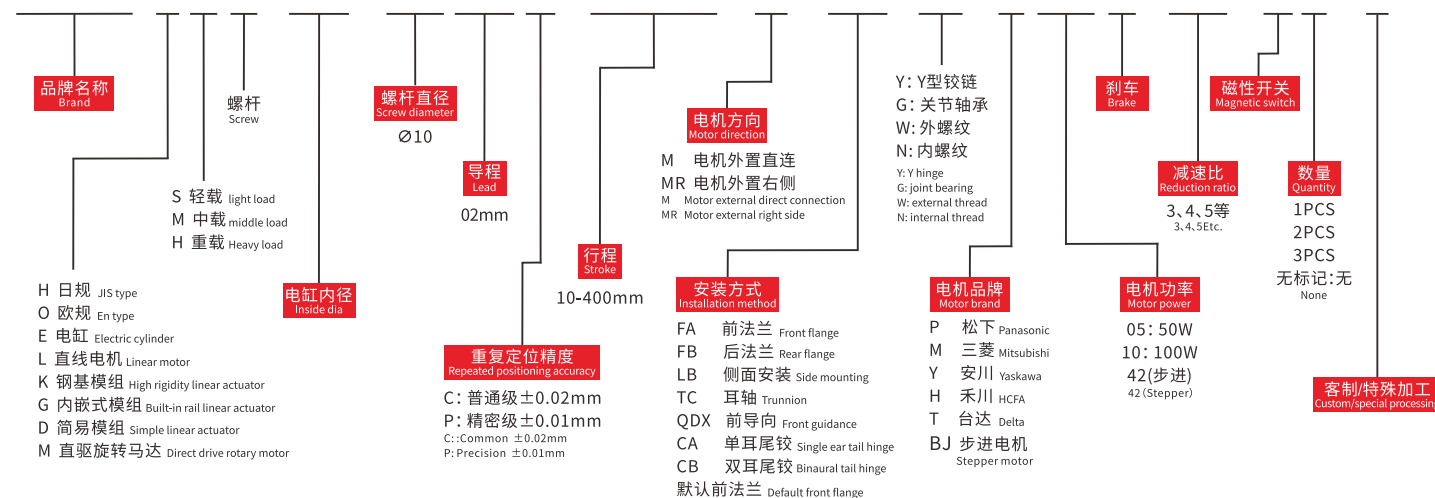

产品性能参数如下 Product performance parameters are as follows

|  |   |      |
|--|---|------|
| 电机功率 (W) Motor power (W)                       | 50  | 100  |
| 额定扭矩 (N.m) Rated torque (N.m)                  | 0.16  | 0.32 |
| 重复定位精度 (mm) Repeated positioning accuracy (mm) | ±0.02   |      |
| 滚珠螺杆导程 (mm) Ball screw lead (mm)               | 2   | 2    |
| 最高速度 (mm/s) Max speed (mm/s)                   | 100   | 100  |
| 电机额定转速 (RPM) Rated speed of motor (RPM)        | 3000  |      |
| 最大可搬重量 (KG) Maximum Payload (kg)               | 40kg  |      |
| 传动方式 Drive method                              | 滚珠螺杆C7转造/C5研磨(默认C7)<br>Ball screw C7 conversion /C5 grinding (default C7) |      |
| 额定推力 (N) Rated thrust (N)                      | 425   | 950  |
| 有效行程 (mm) Valid stroke (mm)                    | 10~400mm  |      |
| 滚珠螺杆外径 (mm) Ball screw Ø (mm)                  | Ø10   |      |
| 外部材质 External material                         | 铝型材 Aluminium profile   |      |
| 开关 Switch                                      | 磁感应开关 Magnetic switch   |      |
| 使用环境 Operating environment                     | -10~70°C, 85%RH(无凝结) No condensation                                      |      |

※注1: 电缸内螺杆可承受40kg。  
Note 1: The screw rod in the electric cylinder can bear 40kg.

感应器连接图<原点及端点> Sensor layout

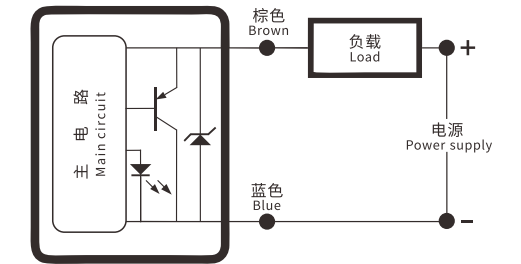

搭配伺服马达一览表 Suitable motor brand

|              |                  | 伺服电机外形尺寸 servo motor size                               |       |                     |    |     |     |    |    |    |     |     |    |     |      |       |    |    |
|--------------|------------------|---|-------|---------------------|----|-----|-----|----|----|----|-----|-----|----|-----|------|-------|----|----|
| 功率 Power (w) | 品牌 Brand         | 型号 Model  | LL    | LL(刹车)<br>LL(Brake) | LA | LE  | LZ  | LC | LG | LW | RH  | W   | LR | S   | LB   | M     | QK | QL |
| 100W         | 三菱<br>Mitsubishi | HC-KFS12□K<br>B:带刹车 □:无刹车<br>B:With brake □:No brake    | 86.5  | 124.5               | 46 | 2.5 | 4.5 | 42 | 5  | -  | -   | -   | 25 | 8h6 | 30h7 | -     | -  | -  |
|              | 松下<br>Panasonic  | MSMD012G1□<br>V:带刹车 U:无刹车<br>V:With brake U:No brake    | 92    | 122                 | 45 | 3   | 3.4 | 38 | 6  | 14 | 6.2 | 3h9 | 25 | 8h6 | 30h7 | M3x6L | -  | -  |
|              | 台达<br>Delta      | ECMA-C20401□S<br>S:带刹车 R:无刹车<br>S:With brake R:No brake | 100.6 | 136.6               | 46 | 2.5 | 4.5 | 40 | 5  | 16 | 6.2 | 3   | 25 | 8h6 | 30h7 | M3x8L | -  | -  |

前端连接方式 Front end connection mode

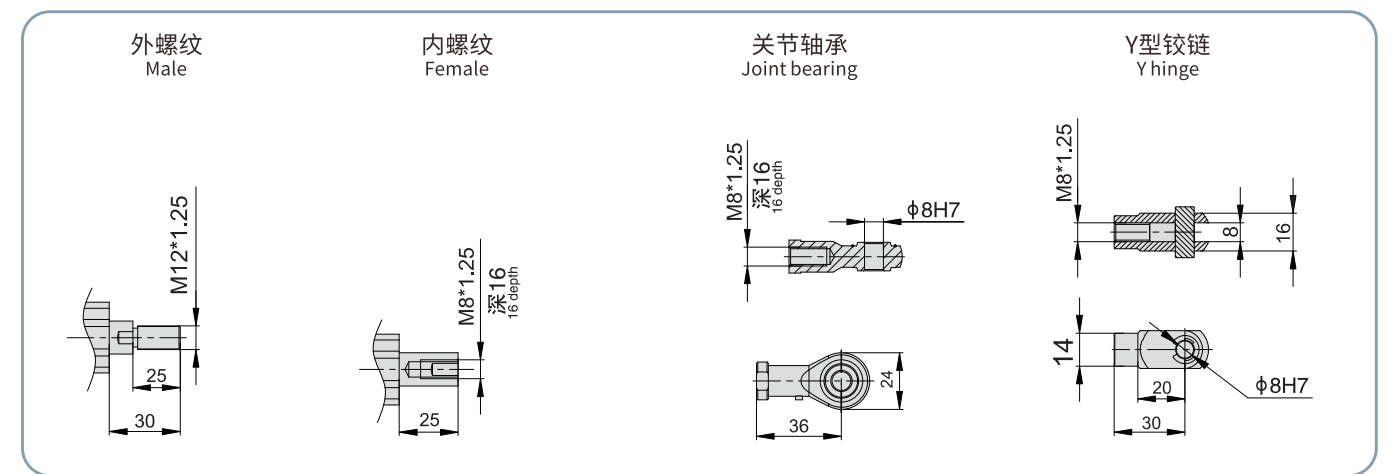

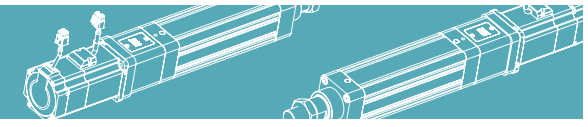

电机外置直连/电机外置右侧  
Motor external direct connection/Motor external right side

M 电机外置直连 Motor external direct connection

单位:Unit: mm

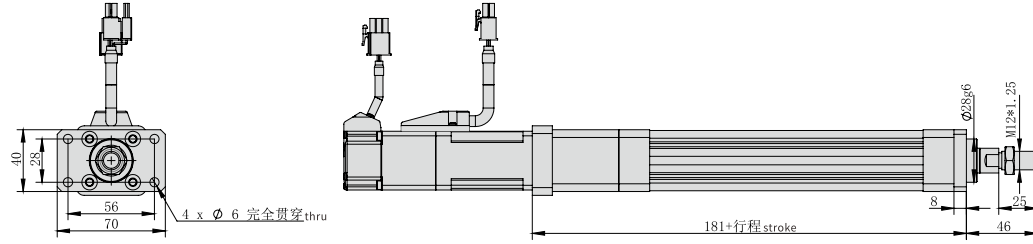

| FA 前法兰<br>Front flange | 有效行程<br>Valid stroke | 50   | 100 | 150  | 200 | 250  | 300 | 350  | 400 |
|------------------------|----------------------|------|-----|------|-----|------|-----|------|-----|
|                        | KG                   | 1.35 | 1.5 | 1.65 | 1.8 | 1.95 | 2.1 | 2.25 | 2.4 |

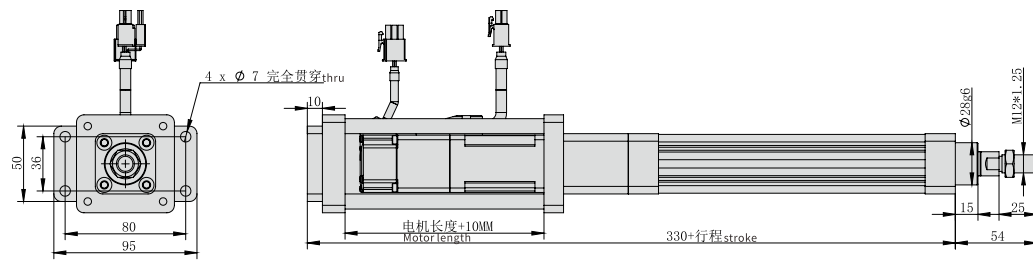

| FB 后法兰<br>Rear flange | 有效行程<br>Valid stroke | 50   | 100  | 150  | 200  | 250  | 300  | 350  | 400  |
|-----------------------|----------------------|------|------|------|------|------|------|------|------|
|                       | KG                   | 1.88 | 2.03 | 2.18 | 2.33 | 2.48 | 2.63 | 2.78 | 2.93 |

备注:每增加10行程,重量增加0.03kg。Note: for each additional 10 strokes, the weight will increase by 0.03kg.

M 电机外置直连 Motor external direct connection

单位:Unit: mm

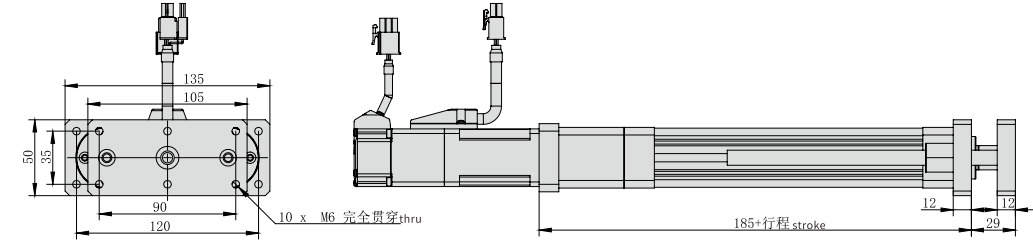

| QDX 前导向<br>Front guidance | 有效行程<br>Valid stroke | 50   | 100  | 150  | 200  | 250  | 300  | 350  | 400  |
|---------------------------|----------------------|------|------|------|------|------|------|------|------|
|                           | KG                   | 1.89 | 2.04 | 2.19 | 2.34 | 2.49 | 2.64 | 2.79 | 2.94 |

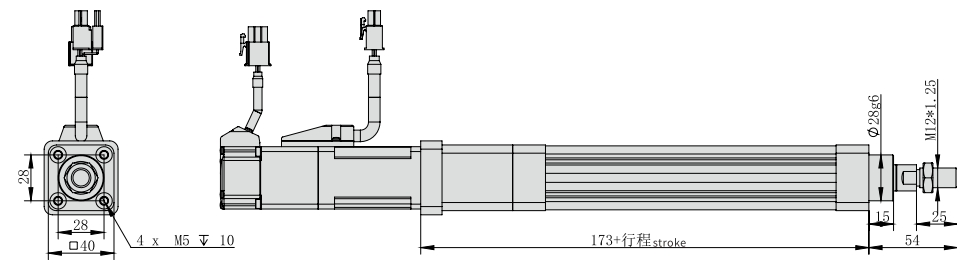

| 前端盖<br>Front end cover | 有效行程<br>Valid stroke | 50   | 100  | 150  | 200  | 250  | 300  | 350  | 400  |
|------------------------|----------------------|------|------|------|------|------|------|------|------|
|                        | KG                   | 1.33 | 1.48 | 1.63 | 1.78 | 1.93 | 2.08 | 2.23 | 2.38 |

备注:每增加10行程,重量增加0.03kg。Note: for each additional 10 strokes, the weight will increase by 0.03kg.

M 电机外置直连 Motor external direct connection

单位:Unit: mm

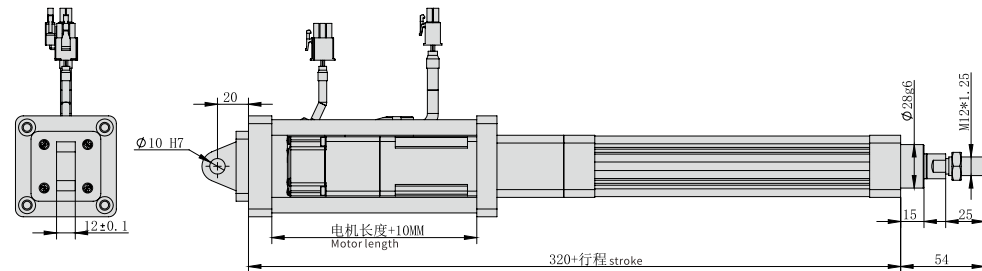

| CA 单耳尾铰<br>Single ear hinge | 有效行程<br>Valid stroke | 50   | 100  | 150  | 200  | 250  | 300  | 350  | 400  |
|-----------------------------|----------------------|------|------|------|------|------|------|------|------|
|                             | KG                   | 2.02 | 2.17 | 2.32 | 2.47 | 2.62 | 2.77 | 2.92 | 3.07 |

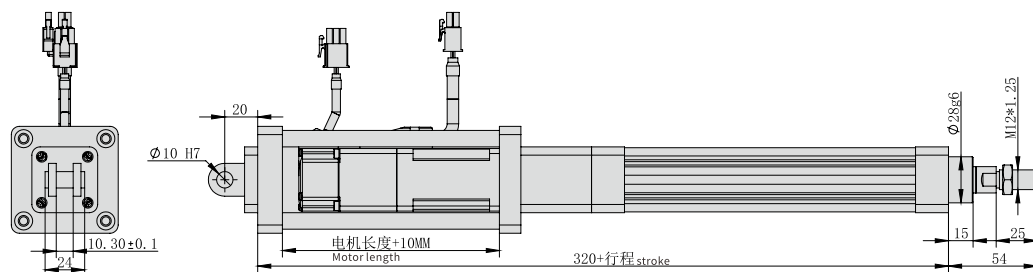

| CB 双耳尾铰<br>Ears end hinged | 有效行程<br>Valid stroke | 50   | 100  | 150  | 200  | 250  | 300  | 350  | 400  |
|----------------------------|----------------------|------|------|------|------|------|------|------|------|
|                            | KG                   | 2.01 | 2.16 | 2.31 | 2.46 | 2.61 | 2.76 | 2.91 | 3.06 |

备注:每增加10行程,重量增加0.03kg。Note: for each additional 10 strokes, the weight will increase by 0.03kg.

M 电机外置直连 Motor external direct connection

单位:Unit: mm

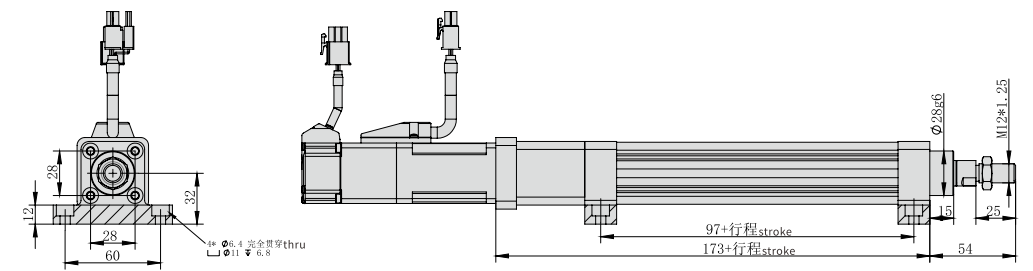

| LB 侧面安装<br>Single ear hinge | 有效行程<br>Valid stroke | 50   | 100  | 150  | 200  | 250  | 300  | 350  | 400  |
|-----------------------------|----------------------|------|------|------|------|------|------|------|------|
|                             | KG                   | 1.43 | 1.58 | 1.73 | 1.88 | 2.03 | 2.18 | 2.33 | 2.48 |

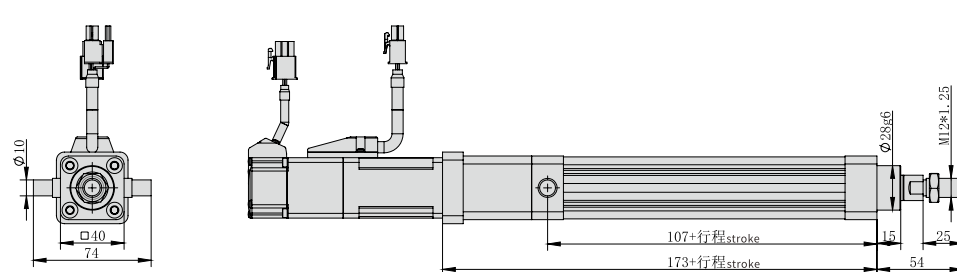

| TC 耳轴<br>Trunnion | 有效行程<br>Valid stroke | 50   | 100  | 150  | 200  | 250  | 300  | 350  | 400  |
|-------------------|----------------------|------|------|------|------|------|------|------|------|
|                   | KG                   | 1.34 | 1.49 | 1.64 | 1.79 | 1.94 | 2.09 | 2.24 | 2.39 |

备注:每增加10行程,重量增加0.03kg。Note: for each additional 10 strokes, the weight will increase by 0.03kg.

- HNR
- HCR
- HNB
- HCB
- HNT
- XYZ
- ONB
- OCB
- GCR
- GCB
- GCBS
- GCRS
- ESR**
- EMR**
- EHR**
- KSR
- LNP
- DDR
- 参考资料  
Reference data

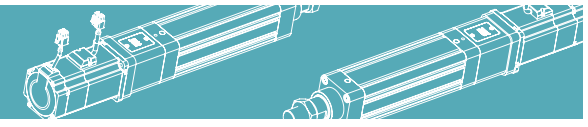

电机外置直连/电机外置右侧  
Motor external direct connection/Motor external right side

MR 电机外置右侧 Motor external right side

单位:Unit: mm

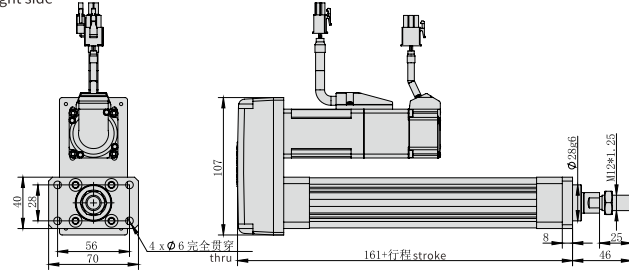

| FA 前法兰<br>Front flange | 有效行程<br>Valid stroke | 50   | 100 | 150  | 200 | 250  | 300 | 350  | 400 |
|------------------------|----------------------|------|-----|------|-----|------|-----|------|-----|
|                        | KG                   | 1.55 | 1.7 | 1.85 | 2   | 2.15 | 2.3 | 2.45 | 2.6 |

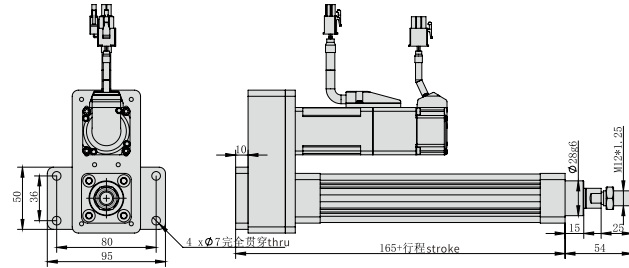

| FB 后法兰<br>Rear flange | 有效行程<br>Valid stroke | 50   | 100  | 150  | 200  | 250  | 300  | 350  | 400  |
|-----------------------|----------------------|------|------|------|------|------|------|------|------|
|                       | KG                   | 2.08 | 2.23 | 2.38 | 2.53 | 2.68 | 2.83 | 2.98 | 3.13 |

备注:每增加10行程,重量增加0.03kg。 Note: for each additional 10 strokes, the weight will increase by 0.03kg.

MR 电机外置右侧 Motor external right side

单位:Unit: mm

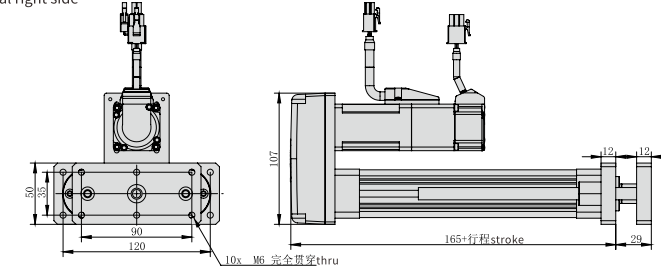

| QDX 前导向<br>Front guidance | 有效行程<br>Valid stroke | 50   | 100  | 150  | 200  | 250  | 300  | 350  | 400  |
|---------------------------|----------------------|------|------|------|------|------|------|------|------|
|                           | KG                   | 2.09 | 2.24 | 2.39 | 2.54 | 2.69 | 2.84 | 2.99 | 3.14 |

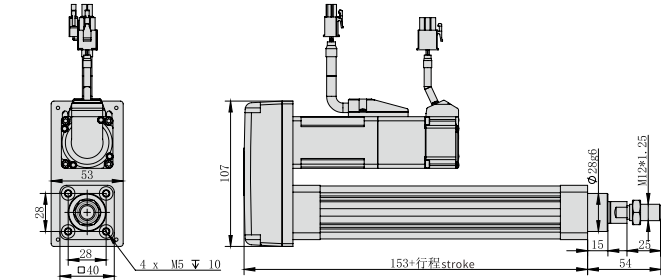

| 前端盖<br>Front end cover | 有效行程<br>Valid stroke | 50   | 100  | 150  | 200  | 250  | 300  | 350  | 400  |
|------------------------|----------------------|------|------|------|------|------|------|------|------|
|                        | KG                   | 1.53 | 1.68 | 1.83 | 1.98 | 2.13 | 2.28 | 2.43 | 2.58 |

备注:每增加10行程,重量增加0.03kg。 Note: for each additional 10 strokes, the weight will increase by 0.03kg.

MR 电机外置右侧 Motor external right side

单位:Unit: mm

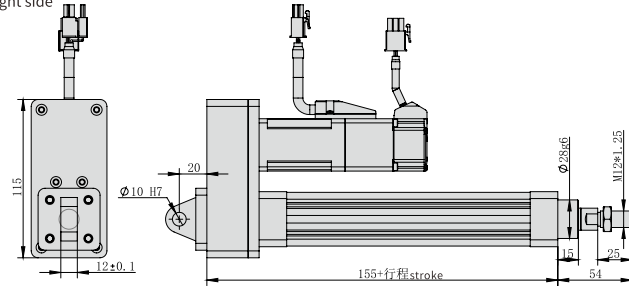

| CA 单耳尾铰<br>Single ear hinge | 有效行程<br>Valid stroke | 50   | 100  | 150  | 200  | 250  | 300  | 350  | 400  |
|-----------------------------|----------------------|------|------|------|------|------|------|------|------|
|                             | KG                   | 2.22 | 2.37 | 2.52 | 2.67 | 2.82 | 2.97 | 3.12 | 3.27 |

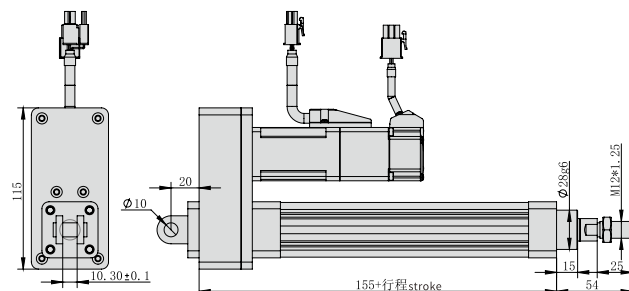

| CB 双耳尾铰<br>Ears end hinged | 有效行程<br>Valid stroke | 50   | 100  | 150  | 200  | 250  | 300  | 350  | 400  |
|----------------------------|----------------------|------|------|------|------|------|------|------|------|
|                            | KG                   | 2.21 | 2.36 | 2.51 | 2.66 | 2.81 | 2.96 | 3.11 | 3.26 |

备注:每增加10行程,重量增加0.03kg。 Note: for each additional 10 strokes, the weight will increase by 0.03kg.

MR 电机外置右侧 Motor external right side

单位:Unit: mm

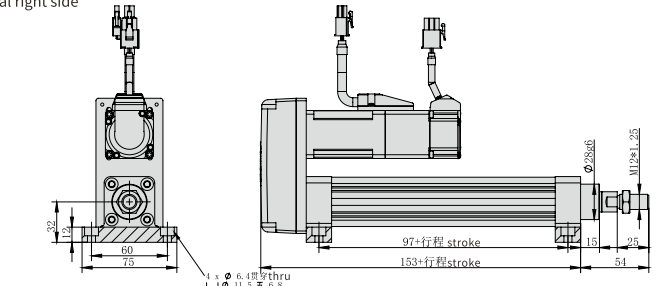

| LB 侧面安装<br>Single ear hinge | 有效行程<br>Valid stroke | 50   | 100  | 150  | 200  | 250  | 300  | 350  | 400  |
|-----------------------------|----------------------|------|------|------|------|------|------|------|------|
|                             | KG                   | 1.63 | 1.78 | 1.93 | 2.08 | 2.23 | 2.38 | 2.53 | 2.68 |

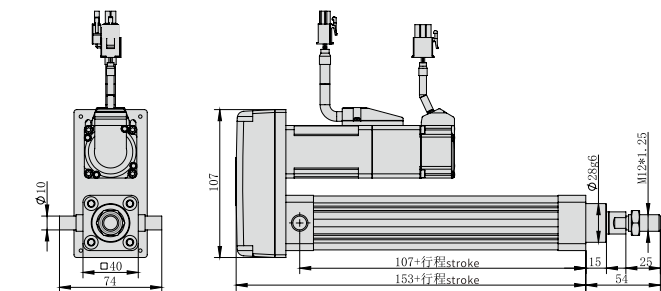

| TC 耳轴<br>Trunnion | 有效行程<br>Valid stroke | 50   | 100  | 150  | 200  | 250  | 300  | 350  | 400  |
|-------------------|----------------------|------|------|------|------|------|------|------|------|
|                   | KG                   | 1.54 | 1.69 | 1.84 | 1.99 | 2.14 | 2.29 | 2.44 | 2.59 |

备注:每增加10行程,重量增加0.03kg。 Note: for each additional 10 strokes, the weight will increase by 0.03kg.

- HNR
- HCR
- HNB
- HCB
- HNT
- XYZ
- ONB
- OCB
- GCR
- GCB
- GCBS
- GCRS
- ESR**
- EMR**
- EHR**
- KSR
- LNP
- DDR
- 参考资料  
Reference data

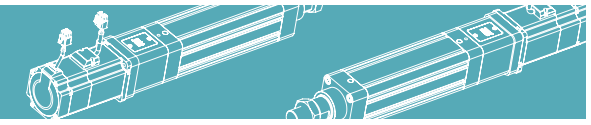

重复精度  
Repeat Accuracy  
±0.02  
mm

此图仅供参考, 出货规格详见尺寸图面  
This picture for reference only, specs details according with the drawing.

最大行程  
Max Stroke 600mm

最高速度  
Max Speed 500mm/s

电机额定功率  
Rated power of motor 400W

滚珠螺杆  
Ball screw Ø12mm

型号表达方式 Ordering method

TPA-ESR-40-1205C-L200-M-FA-W-P20B-J3-C3-F

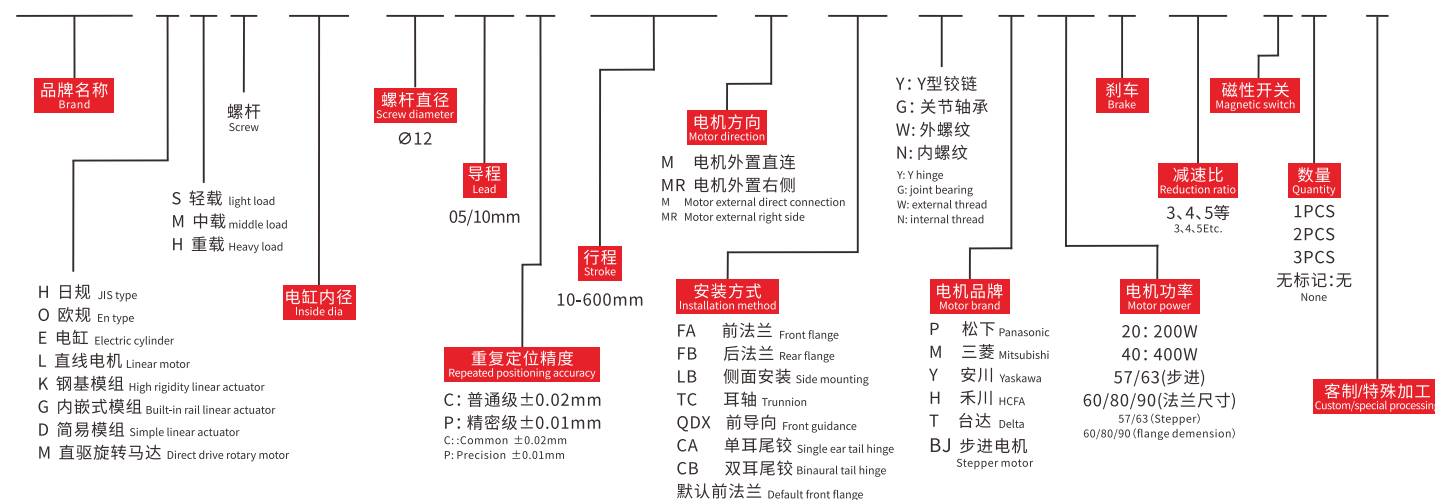

产品性能参数如下 Product performance parameters are as follows

|                   |  |                                       |      |
|-------------------|--|---------------------------------------|------|
| 规格<br>Spec        | 电机功率 (W) Motor power (W)   | 200                                   | 400  |
|                   | 额定扭矩 (N.m) Rated torque (N.m)  | 0.64                                  | 1.27 |
|                   | 重复定位精度 (mm) Repeated positioning accuracy (mm)                             | ±0.02                                 |      |
|                   | 滚珠螺杆导程 (mm) Ball screw lead (mm)   | 5                                     | 10   |
|                   | 最高速度 (mm/s) Max speed (mm/s)   | 250                                   | 500  |
|                   | 电机额定转速 (RPM) Rated speed of motor (RPM)                                    | 3000                                  |      |
|                   | 最大可搬重量 (KG) Maximum Payload (kg)   | 150kg                                 |      |
| 传动方式 Drive method | 滚珠螺杆C7转造/C5研磨 (默认C7)<br>Ball screw C7 conversion /C5 grinding (default C7) |                                       |      |
|                   | 额定推力 (N) Rated thrust (N)  | 680                                   | 340  |
|                   | 有效行程 (mm) Valid stroke (mm)  | 10~600mm                              |      |
|                   | 滚珠螺杆外径 (mm) Ball screw Ø (mm)  | Ø12                                   |      |
| 部品<br>Parts       | 外部材质 External material   | 铝型材 Aluminium profile                 |      |
|                   | 开关 Switch  | 磁感应开关 Magnetic switch                 |      |
|                   | 使用环境 Operating environment   | -10~70°C, 85%RH (无凝露) No condensation |      |

传感器连接图<原点及端点> Sensor layout

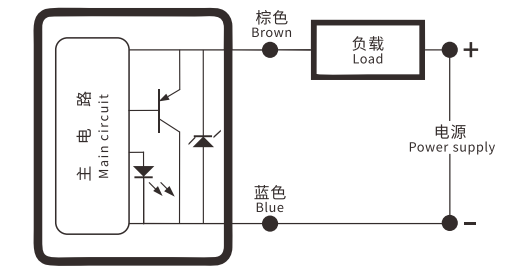

搭配伺服马达一览表 Suitable motor brand

| 伺服电机外形尺寸 servo motor size |                  |               |  |                     |       |    |    |     |    |     |    |    |     |    |      |      |        |    |   |
|---------------------------|------------------|---------------|--|---------------------|-------|----|----|-----|----|-----|----|----|-----|----|------|------|--------|----|---|
| 功率 Power (w)              | 品牌 Brand         | 型号 Model      | LL                                       | LL(刹车)<br>LL(Brake) | LA    | LE | LZ | LC  | LG | LW  | RH | W  | LR  | S  | LB   | M    | QK     | QL |   |
| 400W                      | 三菱<br>Mitsubishi | HC-KFS43□K    | B:带刹车 □:无刹车<br>B: With brake □: No brake | 124.5               | 165.5 | 70 | 3  | 5.8 | 62 | 7   | -  | -  | -   | 30 | 14h6 | 50h7 | -      | -  | - |
|                           | 松下<br>Panasonic  | MSMJ042G1□    | V:带刹车 U:无刹车<br>V: With brake U: No brake | 99                  | 135   | 70 | 3  | 4.5 | 60 | 6.5 | 20 | 11 | 5h9 | 30 | 14h6 | 50h7 | M5x10L | -  | - |
|                           | 台达<br>Delta      | ECMA-C20604□S | S:带刹车 R:无刹车<br>S: With brake R: No brake | 130.7               | 166.6 | 70 | 3  | 5.5 | 60 | 7.5 | 20 | 11 | 5   | 30 | 14h6 | 70h7 | M4x15L | -  | - |
|                           | 台达<br>Delta      | ECMA-C20804□S | S:带刹车 R:无刹车<br>S: With brake R: No brake | 112.3               | 152.8 | 90 | 3  | 6.6 | 80 | 8   | 20 | 11 | 5   | 35 | 14h6 | 50h7 | M4x15L | -  | - |

前端连接方式 Front end connection mode

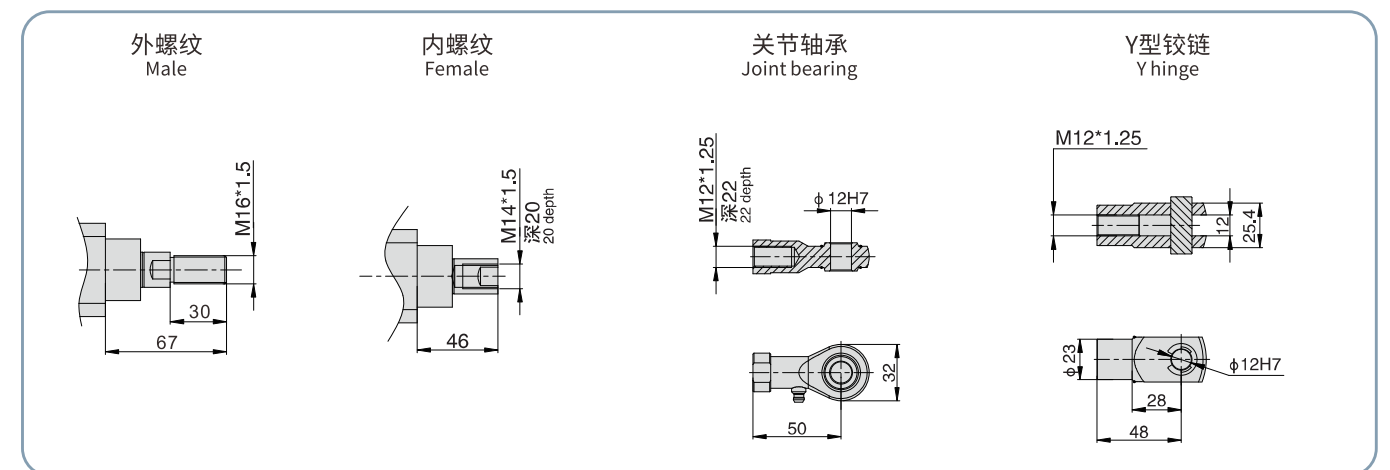

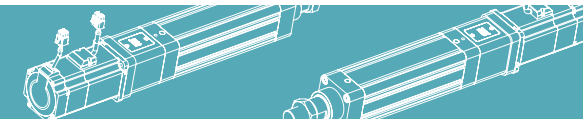

电机外置直连/电机外置右侧  
Motor external direct connection/Motor external right side

M 电机外置直连 Motor external direct connection 单位:Unit: mm

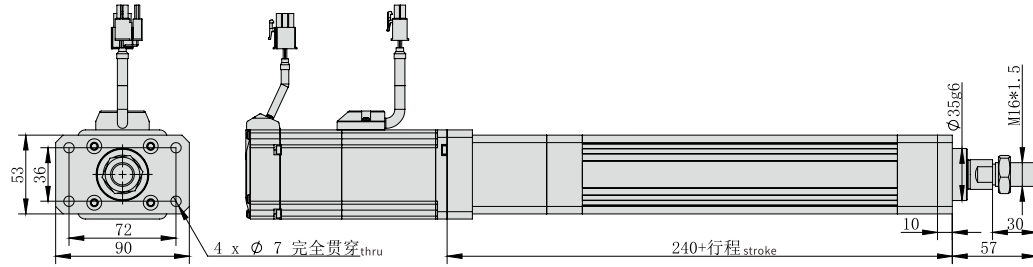

| FA 前法兰<br>Front flange | 有效行程<br>Valid stroke | 50   | 100  | 150  | 200 | 250  | 300  | 350  | 400 | 450  | 500  | 550  | 600 |
|------------------------|----------------------|------|------|------|-----|------|------|------|-----|------|------|------|-----|
|                        | KG                   | 2.75 | 3.00 | 3.25 | 3.5 | 3.75 | 4.00 | 4.25 | 4.5 | 4.75 | 5.00 | 5.25 | 5.5 |

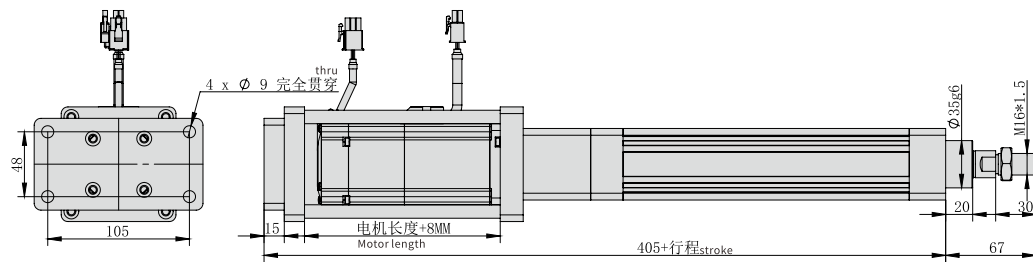

| FB 后法兰<br>Rear flange | 有效行程<br>Valid stroke | 50   | 100  | 150  | 200  | 250  | 300  | 350  | 400  | 450  | 500  | 550  | 600  |
|-----------------------|----------------------|------|------|------|------|------|------|------|------|------|------|------|------|
|                       | KG                   | 3.68 | 3.93 | 4.18 | 4.43 | 4.68 | 4.93 | 5.18 | 5.43 | 5.68 | 5.93 | 6.18 | 6.43 |

备注:每增加10行程,重量增加0.03kg。 Note: for each additional 10 strokes, the weight will increase by 0.03kg.

M 电机外置直连 Motor external direct connection 单位:Unit: mm

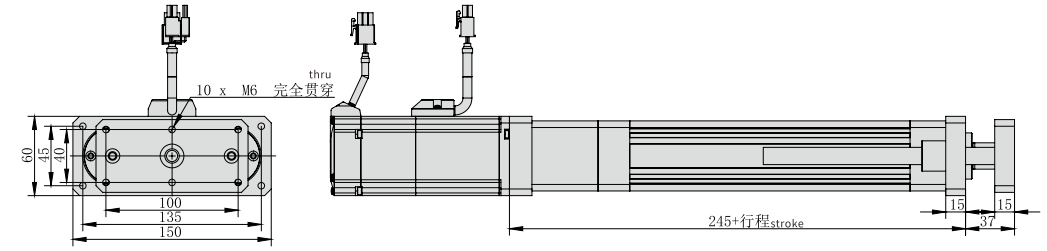

| QDX 前导向<br>Front guidance | 有效行程<br>Valid stroke | 50   | 100  | 150  | 200  | 250  | 300  | 350  | 400  | 450  | 500  | 550  | 600  |
|---------------------------|----------------------|------|------|------|------|------|------|------|------|------|------|------|------|
|                           | KG                   | 3.92 | 4.17 | 4.42 | 4.67 | 4.92 | 5.17 | 5.42 | 5.67 | 5.92 | 6.17 | 6.42 | 6.67 |

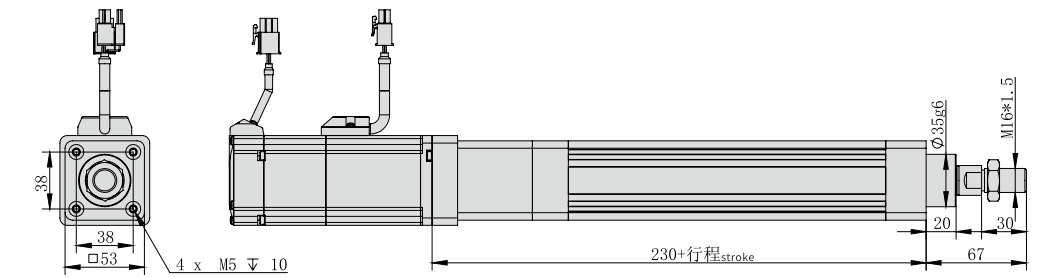

| 前端盖<br>Front end cover | 有效行程<br>Valid stroke | 50   | 100  | 150  | 200  | 250  | 300  | 350  | 400  | 450  | 500  | 550  | 600  |
|------------------------|----------------------|------|------|------|------|------|------|------|------|------|------|------|------|
|                        | KG                   | 2.72 | 2.97 | 3.22 | 3.47 | 3.72 | 3.97 | 4.22 | 4.47 | 4.72 | 4.97 | 5.22 | 5.47 |

备注:每增加10行程,重量增加0.03kg。 Note: for each additional 10 strokes, the weight will increase by 0.03kg.

M 电机外置直连 Motor external direct connection 单位:Unit: mm

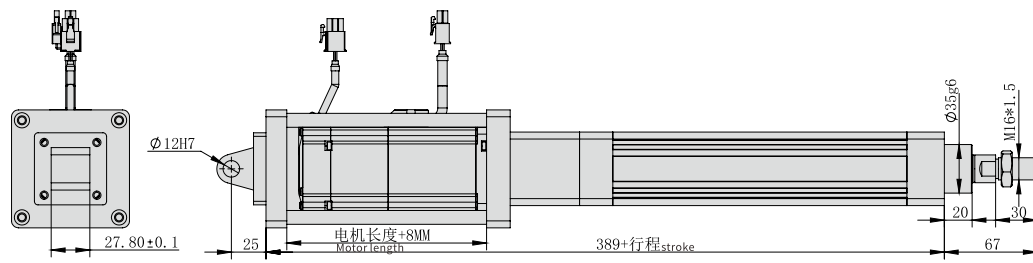

| CA 单耳尾铰<br>Single ear hinge | 有效行程<br>Valid stroke | 50   | 100  | 150  | 200  | 250  | 300  | 350  | 400  | 450  | 500  | 550  | 600  |
|-----------------------------|----------------------|------|------|------|------|------|------|------|------|------|------|------|------|
|                             | KG                   | 3.86 | 4.11 | 4.36 | 4.61 | 4.86 | 5.11 | 5.36 | 5.61 | 5.86 | 6.11 | 6.36 | 6.61 |

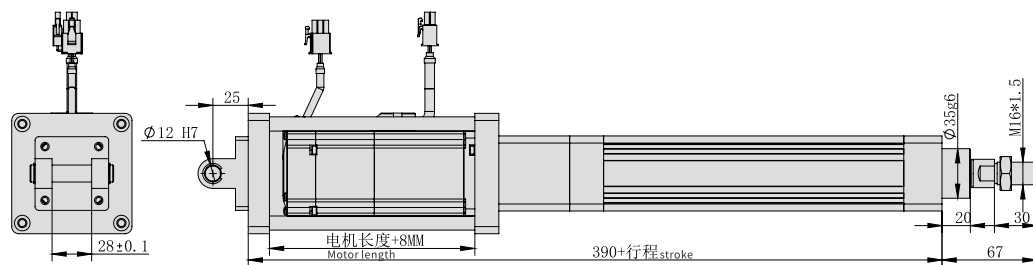

| CB 双耳尾铰<br>Ears end hinged | 有效行程<br>Valid stroke | 50  | 100  | 150 | 200  | 250 | 300  | 350 | 400  | 450 | 500  | 550 | 600  |
|----------------------------|----------------------|-----|------|-----|------|-----|------|-----|------|-----|------|-----|------|
|                            | KG                   | 3.8 | 4.05 | 4.3 | 4.55 | 4.8 | 5.05 | 5.3 | 5.55 | 5.8 | 6.05 | 6.3 | 6.55 |

备注:每增加10行程,重量增加0.03kg。 Note: for each additional 10 strokes, the weight will increase by 0.03kg.

M 电机外置直连 Motor external direct connection 单位:Unit: mm

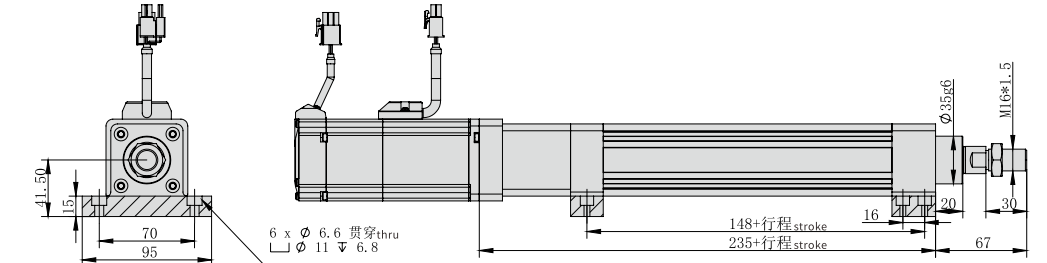

| LB 侧面安装<br>Single ear hinge | 有效行程<br>Valid stroke | 50   | 100  | 150  | 200  | 250  | 300  | 350  | 400  | 450  | 500  | 550  | 600  |
|-----------------------------|----------------------|------|------|------|------|------|------|------|------|------|------|------|------|
|                             | KG                   | 2.94 | 3.19 | 3.44 | 3.69 | 3.94 | 4.19 | 4.44 | 4.69 | 4.94 | 5.19 | 5.44 | 5.69 |

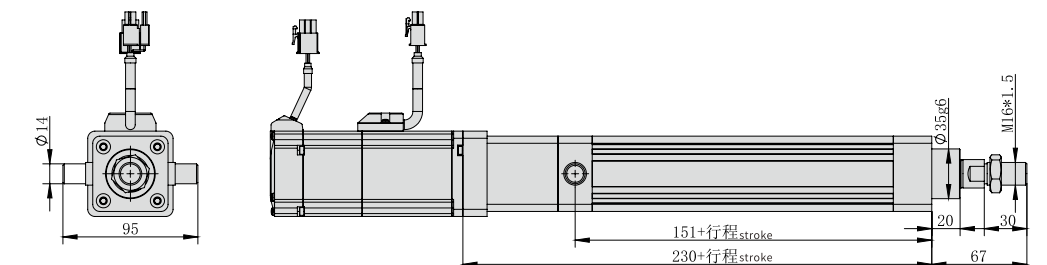

| TC 耳轴<br>Trunnion | 有效行程<br>Valid stroke | 50   | 100  | 150  | 200  | 250  | 300  | 350  | 400  | 450  | 500  | 550  | 600  |
|-------------------|----------------------|------|------|------|------|------|------|------|------|------|------|------|------|
|                   | KG                   | 2.74 | 2.99 | 3.24 | 3.49 | 3.74 | 3.99 | 4.24 | 4.49 | 4.74 | 4.99 | 5.24 | 5.49 |

备注:每增加10行程,重量增加0.03kg。 Note: for each additional 10 strokes, the weight will increase by 0.03kg.

- HNR
- HCR
- HNB
- HCB
- HNT
- XYZ
- ONB
- OCB
- GCR
- GCB
- GCBS
- GCRS
- ESR**
- EMR
- EHR
- KSR
- LNP
- DDR
- 参考资料  
Reference data

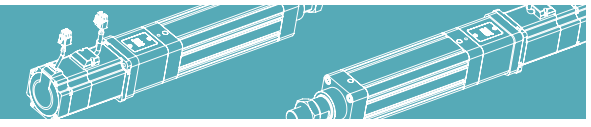

电机外置直连/电机外置右侧  
Motor external direct connection/Motor external right side

MR 电机外置右侧 Motor external right side

单位:Unit: mm

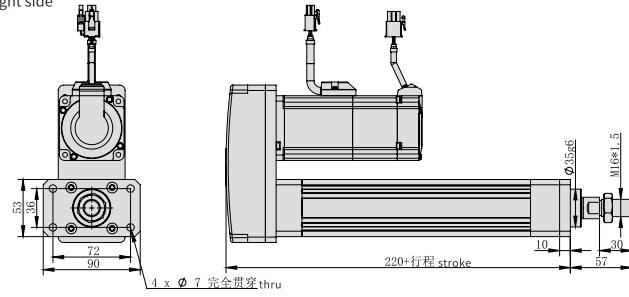

| FA 前法兰<br>Front flange | 有效行程<br>Valid stroke | 50 | 100  | 150  | 200  | 250  | 300  | 350  | 400  | 450  | 500  | 550  | 600  |
|------------------------|----------------------|----|------|------|------|------|------|------|------|------|------|------|------|
|                        |                      | KG | 2.80 | 3.30 | 3.80 | 4.30 | 4.80 | 5.30 | 4.30 | 4.55 | 4.80 | 5.05 | 5.30 |

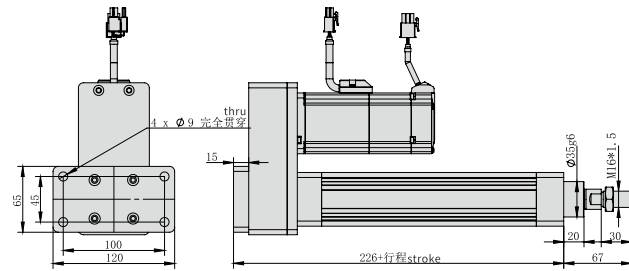

| FB 后法兰<br>Rear flange | 有效行程<br>Valid stroke | 50 | 100  | 150  | 200  | 250  | 300  | 350  | 400  | 450  | 500  | 550  | 600  |
|-----------------------|----------------------|----|------|------|------|------|------|------|------|------|------|------|------|
|                       |                      | KG | 3.72 | 3.97 | 4.22 | 4.47 | 4.72 | 4.97 | 5.22 | 5.47 | 5.72 | 5.97 | 6.22 |

备注:每增加10行程,重量增加0.03kg。 Note: for each additional 10 strokes, the weight will increase by 0.03kg.

MR 电机外置右侧 Motor external right side

单位:Unit: mm

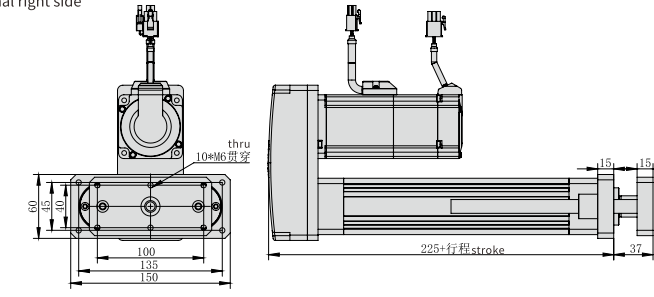

| QDX 前导向<br>Front guidance | 有效行程<br>Valid stroke | 50 | 100  | 150  | 200  | 250  | 300  | 350  | 400  | 450  | 500  | 550  | 600  |
|---------------------------|----------------------|----|------|------|------|------|------|------|------|------|------|------|------|
|                           |                      | KG | 3.97 | 4.22 | 4.47 | 4.72 | 4.97 | 5.22 | 5.47 | 5.72 | 5.97 | 6.22 | 6.47 |

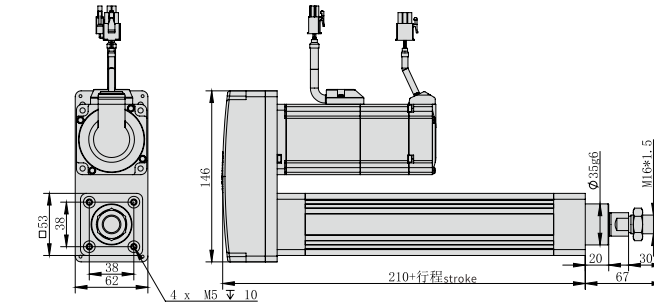

| 前端盖<br>Front end cover | 有效行程<br>Valid stroke | 50 | 100  | 150  | 200  | 250  | 300  | 350  | 400  | 450  | 500  | 550  | 600  |
|------------------------|----------------------|----|------|------|------|------|------|------|------|------|------|------|------|
|                        |                      | KG | 2.77 | 3.02 | 3.27 | 3.52 | 3.77 | 4.02 | 4.27 | 4.52 | 4.77 | 5.02 | 5.27 |

备注:每增加10行程,重量增加0.03kg。 Note: for each additional 10 strokes, the weight will increase by 0.03kg.

MR 电机外置右侧 Motor external right side

单位:Unit: mm

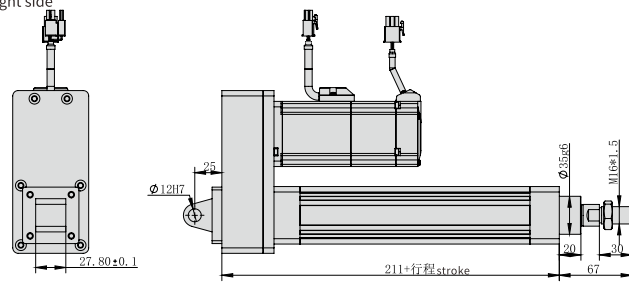

| CA 单耳尾铰<br>Single ear hinge | 有效行程<br>Valid stroke | 50 | 100  | 150  | 200  | 250  | 300  | 350  | 400  | 450  | 500  | 550  | 600  |
|-----------------------------|----------------------|----|------|------|------|------|------|------|------|------|------|------|------|
|                             |                      | KG | 3.91 | 4.16 | 4.41 | 4.66 | 4.91 | 5.16 | 5.41 | 5.66 | 5.91 | 6.16 | 6.41 |

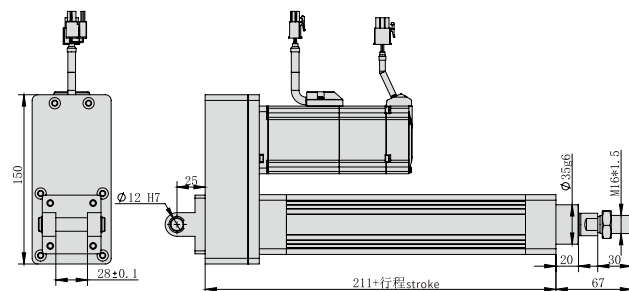

| CB 双耳尾铰<br>Ears end hinged | 有效行程<br>Valid stroke | 50 | 100  | 150 | 200  | 250 | 300  | 350 | 400  | 450 | 500  | 550 | 600  |
|----------------------------|----------------------|----|------|-----|------|-----|------|-----|------|-----|------|-----|------|
|                            |                      | KG | 3.85 | 4.1 | 4.35 | 4.6 | 4.85 | 5.1 | 5.35 | 5.6 | 5.85 | 6.1 | 6.35 |

备注:每增加10行程,重量增加0.03kg。 Note: for each additional 10 strokes, the weight will increase by 0.03kg.

MR 电机外置右侧 Motor external right side

单位:Unit: mm

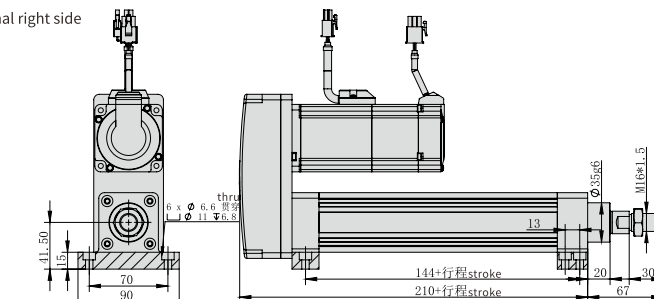

| LB 侧面安装<br>Single ear hinge | 有效行程<br>Valid stroke | 50 | 100  | 150  | 200  | 250  | 300  | 350  | 400  | 450  | 500  | 550  | 600  |
|-----------------------------|----------------------|----|------|------|------|------|------|------|------|------|------|------|------|
|                             |                      | KG | 2.99 | 3.24 | 3.49 | 3.74 | 3.99 | 4.24 | 4.49 | 4.74 | 4.99 | 5.24 | 5.49 |

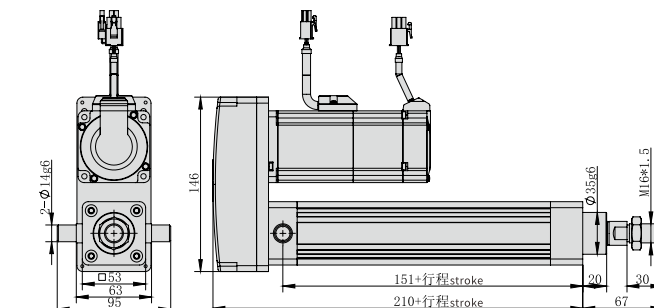

| TC 耳轴<br>Trunnion | 有效行程<br>Valid stroke | 50 | 100  | 150  | 200  | 250  | 300  | 350  | 400  | 450  | 500  | 550  | 600  |
|-------------------|----------------------|----|------|------|------|------|------|------|------|------|------|------|------|
|                   |                      | KG | 2.79 | 3.04 | 3.29 | 3.54 | 3.79 | 4.04 | 4.29 | 4.54 | 4.79 | 5.04 | 5.29 |

备注:每增加10行程,重量增加0.03kg。 Note: for each additional 10 strokes, the weight will increase by 0.03kg.

- HNR
- HCR
- HNB
- HCB
- HNT
- XYZ
- ONB
- OCB
- GCR
- GCB
- GCBS
- GCRS
- ESR**
- EMR**
- EHR**
- KSR
- LNP
- DDR
- 参考资料  
Reference data

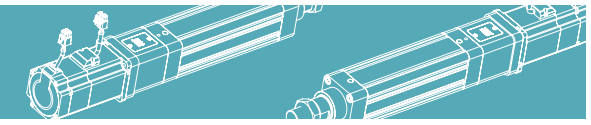

重复精度  
Repeat Accuracy  
±0.02  
mm

此图仅供参考, 出货规格详见尺寸图面  
This picture for reference only, specs details according with the drawing.

最大行程  
Max Stroke 800mm

最高速度  
Max Speed 500mm/s

电机额定功率  
Rated power of motor 400W

滚珠螺杆  
Ball screw Ø16mm

型号表达方式 Ordering method

TPA-ESR-50-1605C-L200-M-FA-W-P20B-J3-C3-F

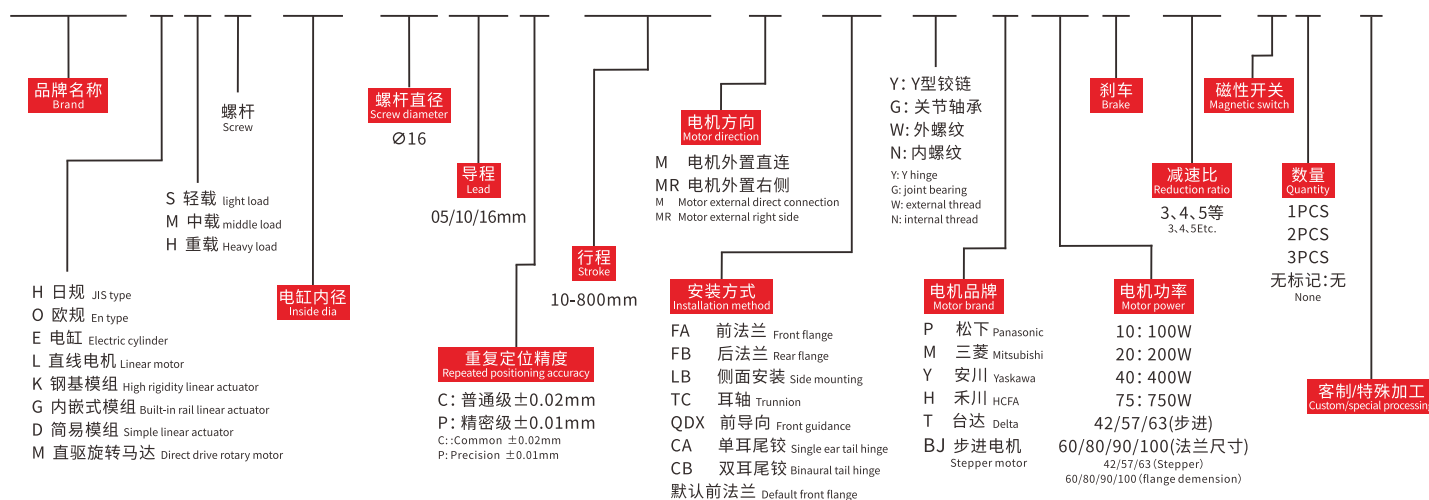

产品性能参数如下 Product performance parameters are as follows

|                            |  |   |      |
|----------------------------|--|---|------|
| 规格<br>Spec                 | 电机功率 (W) Motor power (W)                       | 400   | 750  |
|                            | 额定扭矩 (N.m) Rated torque (N.m)                  | 1.27  | 2.39 |
|                            | 重复定位精度 (mm) Repeated positioning accuracy (mm) | ±0.02   |      |
|                            | 滚珠螺杆导程 (mm) Ball screw lead (mm)               | 5   | 10   |
|                            | 最高速度 (mm/s) Max speed (mm/s)                   | 250   | 500  |
|                            | 电机额定转速 (RPM) Rated speed of motor (RPM)        | 3000  |      |
|                            | 最大可搬重量 (KG) Maximum Payload (kg)               | 300kg   |      |
| 部<br>品<br>Parts            | 传动方式 Drive method                              | 滚珠螺杆C7转造/C5研磨(默认C7)<br>Ball screw C7 conversion /C5 grinding (default C7) |      |
|                            | 额定推力 (N) Rated thrust (N)                      | 1360  | 680  |
|                            | 有效行程 (mm) Valid stroke (mm)                    | 10~800mm  |      |
|                            | 滚珠螺杆外径 (mm) Ball screw Ø (mm)                  | Ø16   |      |
|                            | 外部材质 External material                         | 铝型材 Aluminium profile   |      |
| 开关 Switch                  | 磁感应开关 Magnetic switch                          |   |      |
| 使用环境 Operating environment | -10~70°C, 85%RH(无凝结) No condensation           |   |      |

传感器连接图<原点及端点> Sensor layout

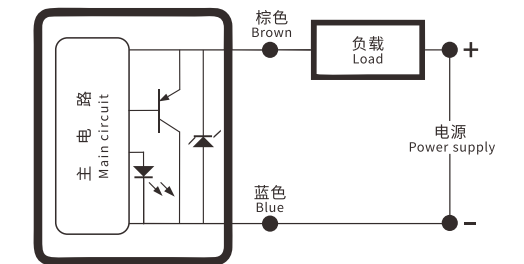

搭配伺服马达一览表 Suitable motor brand

| 伺服电机外形尺寸 servo motor size |               |               |  |                  |       |    |    |     |    |     |    |    |     |    |      |      |        |    |
|---------------------------|---------------|---------------|--|------------------|-------|----|----|-----|----|-----|----|----|-----|----|------|------|--------|----|
| 功率 Power (w)              | 品牌 Brand      | 型号 Model      | LL                                       | LL(刹车) LL(Brake) | LA    | LE | LZ | LC  | LG | LW  | RH | W  | LR  | S  | LB   | M    | QK     | QL |
| 400W                      | 三菱 Mitsubishi | HC-KFS43□K    | B:带刹车 □:无刹车<br>B: With brake □: No brake | 124.5            | 165.5 | 70 | 3  | 5.8 | 62 | 7   | -  | -  | -   | 30 | 14h6 | 50h7 | -      | -  |
|                           | 松下 Panasonic  | MSMJ042G1□    | V:带刹车 U:无刹车<br>V: With brake U: No brake | 99               | 135   | 70 | 3  | 4.5 | 60 | 6.5 | 20 | 11 | 5h9 | 30 | 14h6 | 50h7 | M5x10L | -  |
|                           | 台达 Delta      | ECMA-C20604□S | S:带刹车 R:无刹车<br>S: With brake R: No brake | 130.7            | 166.6 | 70 | 3  | 5.5 | 60 | 7.5 | 20 | 11 | 5   | 30 | 14h6 | 70h7 | M4x15L | -  |
|                           | 台达 Delta      | ECMA-C20804□S | S:带刹车 R:无刹车<br>S: With brake R: No brake | 112.3            | 152.8 | 90 | 3  | 6.6 | 80 | 8   | 20 | 11 | 5   | 35 | 14h6 | 50h7 | M4x15L | -  |

前端连接方式 Front end connection mode

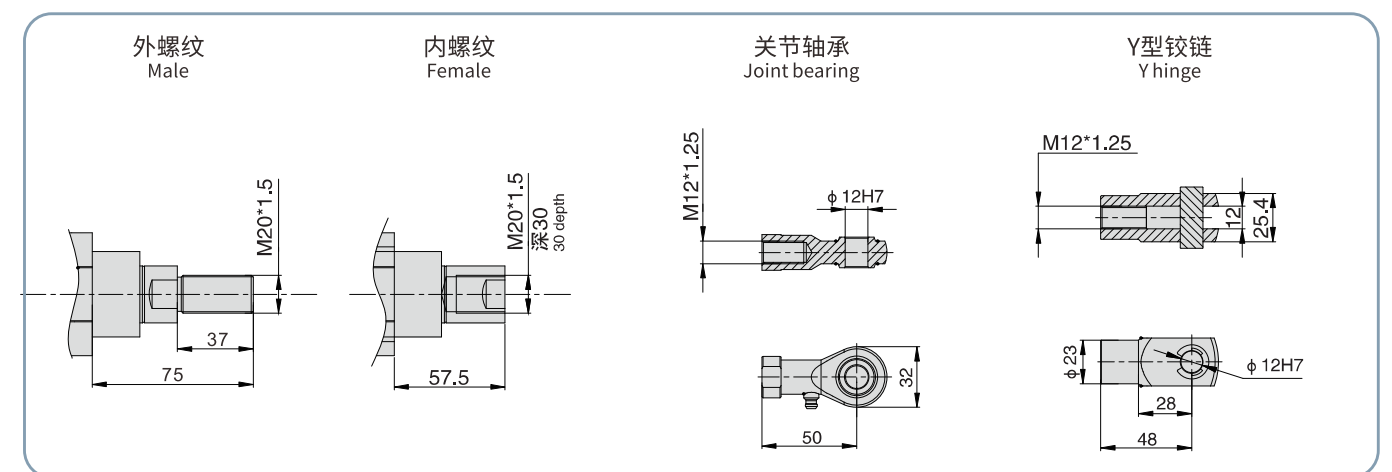

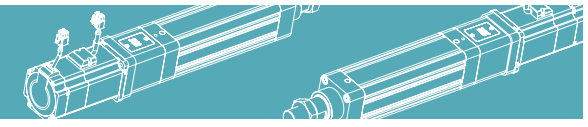

电机外置直连/电机外置右侧  
Motor external direct connection/Motor external right side

M 电机外置直连 Motor external direct connection 单位:Unit: mm

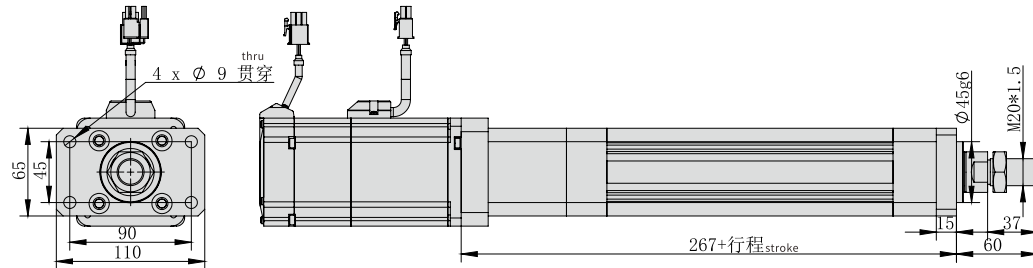

| FA 前法兰<br>Front flange | 有效行程<br>Valid stroke | 50   | 100  | 150  | 200  | 250  | 300  | 350  | 400  | 450  | 500  | 550  | 600  | 650   | 700   | 750   | 800   |
|------------------------|----------------------|------|------|------|------|------|------|------|------|------|------|------|------|-------|-------|-------|-------|
|                        | KG                   | 4.02 | 4.52 | 5.02 | 5.52 | 6.02 | 6.52 | 7.02 | 7.52 | 8.02 | 8.52 | 9.02 | 9.52 | 10.02 | 10.52 | 11.02 | 11.52 |

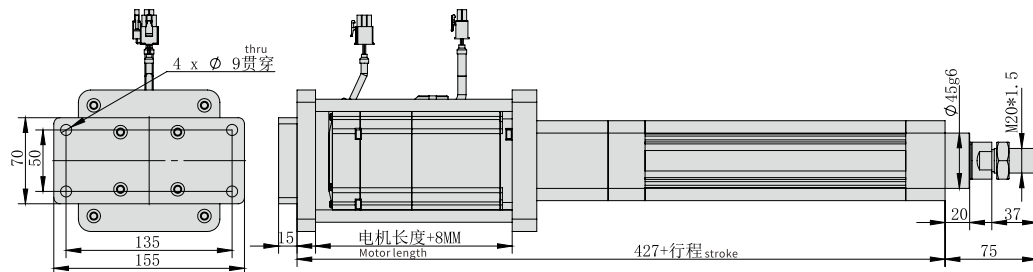

| FB 后法兰<br>Rear flange | 有效行程<br>Valid stroke | 50   | 100  | 150  | 200  | 250  | 300  | 350  | 400  | 450  | 500   | 550   | 600   | 650   | 700   | 750   | 800   |
|-----------------------|----------------------|------|------|------|------|------|------|------|------|------|-------|-------|-------|-------|-------|-------|-------|
|                       | KG                   | 5.59 | 6.09 | 6.59 | 7.09 | 7.59 | 8.09 | 8.59 | 9.09 | 9.59 | 10.09 | 10.59 | 11.09 | 11.59 | 12.09 | 12.59 | 13.09 |

备注:每增加10行程,重量增加0.03kg。 Note: for each additional 10 strokes, the weight will increase by 0.03kg.

M 电机外置直连 Motor external direct connection 单位:Unit: mm

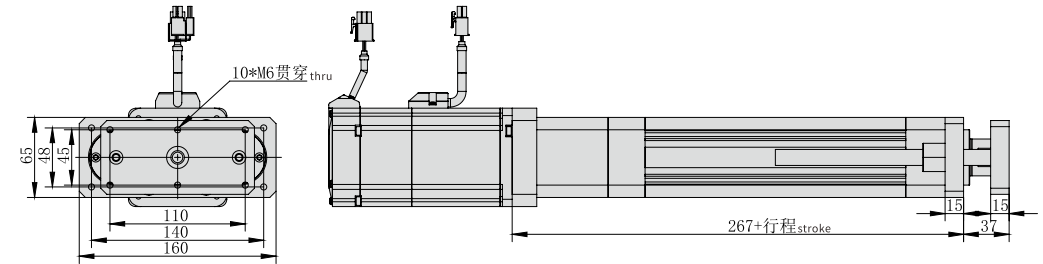

| QDX 前导向<br>Front guidance | 有效行程<br>Valid stroke | 50   | 100  | 150  | 200  | 250  | 300  | 350  | 400  | 450  | 500   | 550   | 600   | 650   | 700   | 750   | 800   |
|---------------------------|----------------------|------|------|------|------|------|------|------|------|------|-------|-------|-------|-------|-------|-------|-------|
|                           | KG                   | 5.50 | 6.00 | 6.50 | 7.00 | 7.50 | 8.00 | 8.50 | 9.00 | 9.50 | 10.00 | 10.50 | 11.00 | 11.50 | 12.00 | 12.50 | 13.00 |

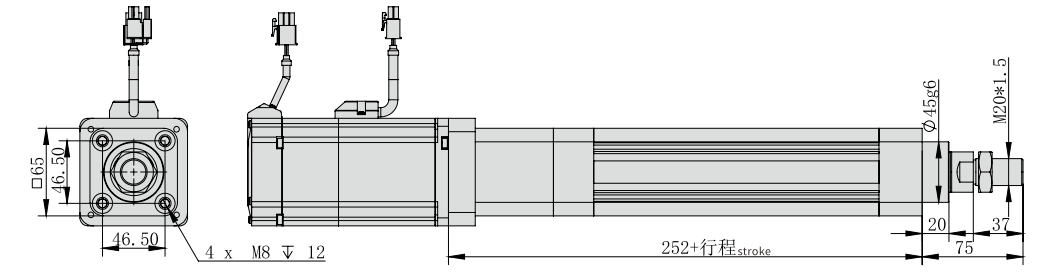

| 前端盖<br>Front end cover | 有效行程<br>Valid stroke | 50   | 100  | 150  | 200  | 250  | 300  | 350  | 400  | 450  | 500  | 550  | 600  | 650  | 700   | 750   | 800   |
|------------------------|----------------------|------|------|------|------|------|------|------|------|------|------|------|------|------|-------|-------|-------|
|                        | KG                   | 3.98 | 4.48 | 4.98 | 5.48 | 5.98 | 6.48 | 6.98 | 7.48 | 7.98 | 8.48 | 8.98 | 9.48 | 9.98 | 10.48 | 10.98 | 11.48 |

备注:每增加10行程,重量增加0.03kg。 Note: for each additional 10 strokes, the weight will increase by 0.03kg.

M 电机外置直连 Motor external direct connection 单位:Unit: mm

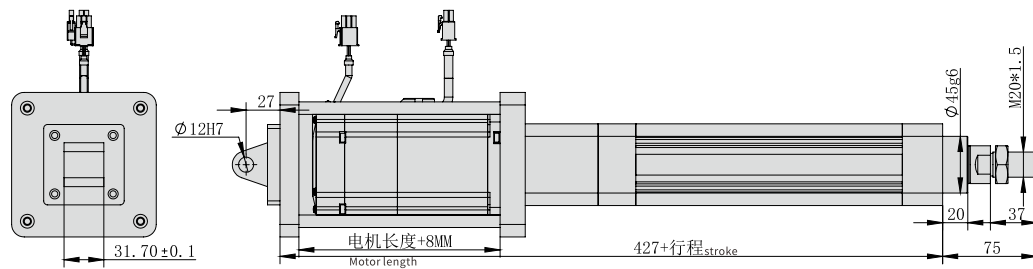

| CA 单耳尾铰<br>Single ear hinge | 有效行程<br>Valid stroke | 50   | 100  | 150  | 200  | 250  | 300  | 350  | 400  | 450  | 500   | 550   | 600   | 650   | 700   | 750   | 800   |
|-----------------------------|----------------------|------|------|------|------|------|------|------|------|------|-------|-------|-------|-------|-------|-------|-------|
|                             | KG                   | 5.65 | 6.15 | 6.65 | 7.15 | 7.65 | 8.15 | 8.65 | 9.15 | 9.65 | 10.15 | 10.65 | 11.15 | 11.65 | 12.15 | 12.65 | 13.15 |

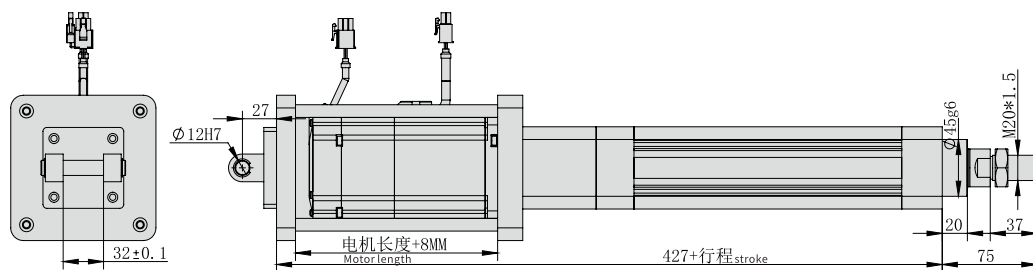

| CB 双耳尾铰<br>Ears end hinged | 有效行程<br>Valid stroke | 50   | 100  | 150  | 200  | 250  | 300  | 350  | 400  | 450  | 500   | 550   | 600   | 650   | 700   | 750   | 800   |
|----------------------------|----------------------|------|------|------|------|------|------|------|------|------|-------|-------|-------|-------|-------|-------|-------|
|                            | KG                   | 5.61 | 6.11 | 6.61 | 7.11 | 7.61 | 8.11 | 8.61 | 9.11 | 9.61 | 10.11 | 10.61 | 11.11 | 11.61 | 12.11 | 12.61 | 13.11 |

备注:每增加10行程,重量增加0.03kg。 Note: for each additional 10 strokes, the weight will increase by 0.03kg.

M 电机外置直连 Motor external direct connection 单位:Unit: mm

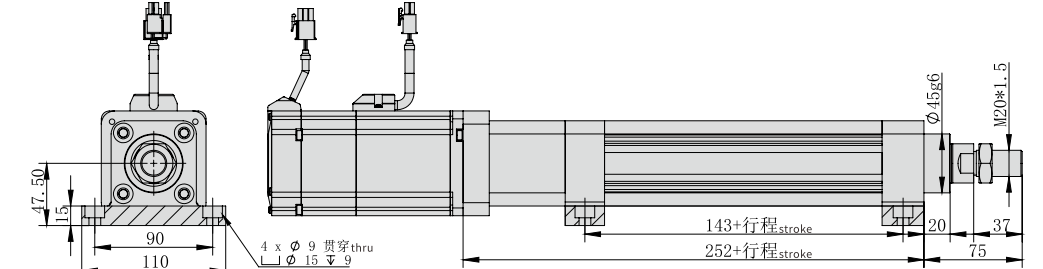

| LB 侧面安装<br>Single ear hinge | 有效行程<br>Valid stroke | 50   | 100  | 150  | 200  | 250  | 300  | 350  | 400  | 450  | 500  | 550  | 600  | 650   | 700   | 750   | 800   |
|-----------------------------|----------------------|------|------|------|------|------|------|------|------|------|------|------|------|-------|-------|-------|-------|
|                             | KG                   | 4.23 | 4.73 | 5.23 | 5.73 | 6.23 | 6.73 | 7.23 | 7.73 | 8.23 | 8.73 | 9.23 | 9.73 | 10.23 | 10.73 | 11.23 | 11.73 |

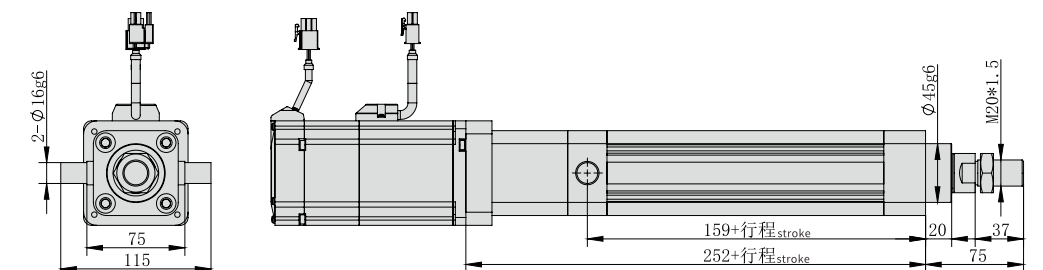

| TC 耳轴<br>Trunnion | 有效行程<br>Valid stroke | 50   | 100  | 150  | 200  | 250  | 300  | 350  | 400  | 450  | 500  | 550  | 600  | 650   | 700   | 750   | 800   |
|-------------------|----------------------|------|------|------|------|------|------|------|------|------|------|------|------|-------|-------|-------|-------|
|                   | KG                   | 4.01 | 4.51 | 5.01 | 5.51 | 6.01 | 6.51 | 7.01 | 7.51 | 8.01 | 8.51 | 9.01 | 9.51 | 10.01 | 10.51 | 11.01 | 11.51 |

备注:每增加10行程,重量增加0.03kg。 Note: for each additional 10 strokes, the weight will increase by 0.03kg.

- HNR
- HCR
- HNB
- HCB
- HNT
- XYZ
- ONB
- OCB
- GCR
- GCB
- GCBS
- GCRS
- ESR**
- EMR
- EHR
- KSR
- LNP
- DDR
- 参考资料  
Reference data



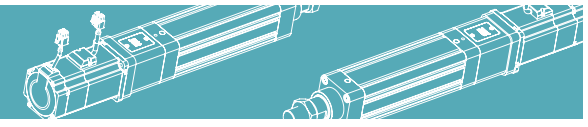

电机外置直连/电机外置右侧  
Motor external direct connection/Motor external right side

MR 电机外置右侧 Motor external right side

单位:Unit: mm

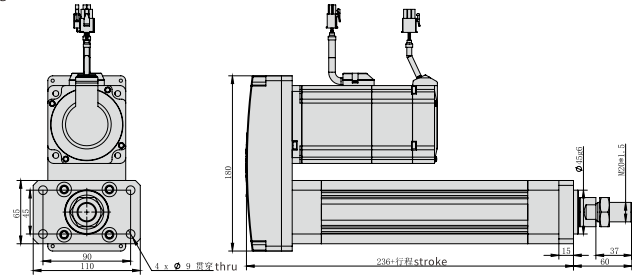

| FA 前法兰<br>Front flange | 有效行程<br>Valid stroke | 50 | 100  | 150  | 200  | 250  | 300  | 350  | 400  | 450  | 500  | 550  | 600  | 650  | 700   | 750   | 800   |
|------------------------|----------------------|----|------|------|------|------|------|------|------|------|------|------|------|------|-------|-------|-------|
|                        |                      | KG | 4.32 | 4.82 | 5.32 | 5.82 | 6.32 | 6.82 | 7.32 | 7.82 | 8.32 | 8.82 | 9.32 | 9.82 | 10.32 | 10.82 | 11.32 |

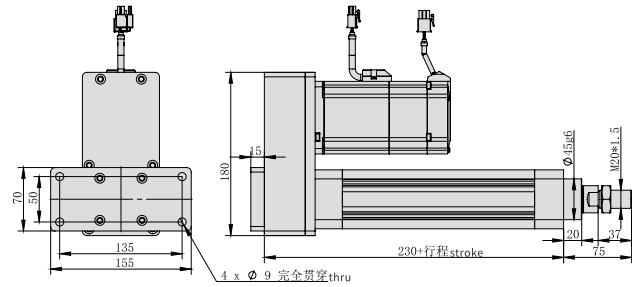

| FB 后法兰<br>Rear flange | 有效行程<br>Valid stroke | 50 | 100  | 150  | 200  | 250  | 300  | 350  | 400  | 450  | 500  | 550   | 600   | 650   | 700   | 750   | 800   |
|-----------------------|----------------------|----|------|------|------|------|------|------|------|------|------|-------|-------|-------|-------|-------|-------|
|                       |                      | KG | 5.89 | 6.39 | 6.89 | 7.39 | 7.89 | 8.39 | 8.89 | 9.39 | 9.89 | 10.39 | 10.89 | 11.39 | 11.89 | 12.39 | 12.89 |

备注:每增加10行程,重量增加0.03kg。 Note: for each additional 10 strokes, the weight will increase by 0.03kg.

MR 电机外置右侧 Motor external right side

单位:Unit: mm

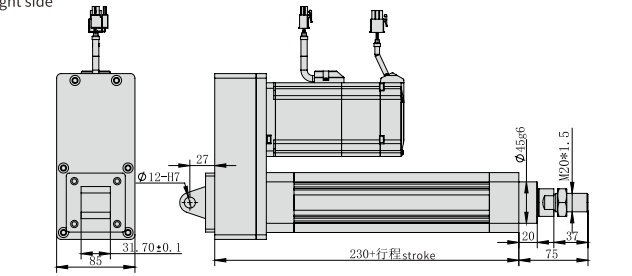

| CA 单耳尾铰<br>Single ear hinge | 有效行程<br>Valid stroke | 50 | 100  | 150  | 200  | 250  | 300  | 350  | 400  | 450  | 500  | 550   | 600   | 650   | 700   | 750   | 800   |
|-----------------------------|----------------------|----|------|------|------|------|------|------|------|------|------|-------|-------|-------|-------|-------|-------|
|                             |                      | KG | 5.95 | 6.45 | 6.95 | 7.45 | 7.95 | 8.45 | 8.95 | 9.45 | 9.95 | 10.45 | 10.95 | 11.45 | 11.95 | 12.45 | 12.95 |

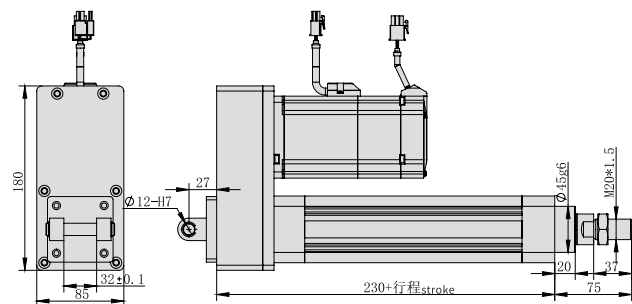

| CB 双耳尾铰<br>Ears end hinged | 有效行程<br>Valid stroke | 50 | 100  | 150  | 200  | 250  | 300  | 350  | 400  | 450  | 500  | 550   | 600   | 650   | 700   | 750   | 800   |
|----------------------------|----------------------|----|------|------|------|------|------|------|------|------|------|-------|-------|-------|-------|-------|-------|
|                            |                      | KG | 5.91 | 6.41 | 6.91 | 7.41 | 7.91 | 8.41 | 8.91 | 9.41 | 9.91 | 10.41 | 10.91 | 11.41 | 11.91 | 12.41 | 12.91 |

备注:每增加10行程,重量增加0.03kg。 Note: for each additional 10 strokes, the weight will increase by 0.03kg.

MR 电机外置右侧 Motor external right side

单位:Unit: mm

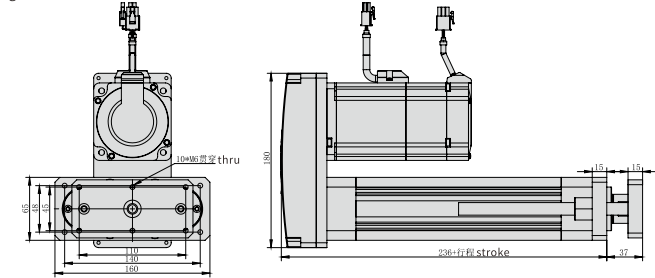

| QDX 前导向<br>Front guidance | 有效行程<br>Valid stroke | 50 | 100  | 150  | 200  | 250  | 300  | 350  | 400  | 450  | 500  | 550   | 600   | 650   | 700   | 750   | 800   |
|---------------------------|----------------------|----|------|------|------|------|------|------|------|------|------|-------|-------|-------|-------|-------|-------|
|                           |                      | KG | 5.80 | 6.30 | 6.80 | 7.30 | 7.80 | 8.30 | 8.80 | 9.30 | 9.80 | 10.30 | 10.80 | 11.30 | 11.80 | 12.30 | 12.80 |

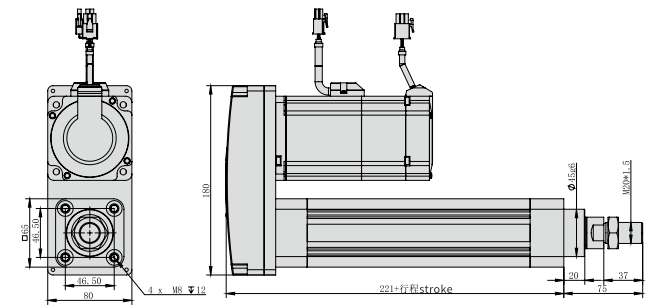

| 前端盖<br>Front end cover | 有效行程<br>Valid stroke | 50 | 100  | 150  | 200  | 250  | 300  | 350  | 400  | 450  | 500  | 550  | 600  | 650  | 700   | 750   | 800   |
|------------------------|----------------------|----|------|------|------|------|------|------|------|------|------|------|------|------|-------|-------|-------|
|                        |                      | KG | 4.28 | 4.78 | 5.28 | 5.78 | 6.28 | 6.78 | 7.28 | 7.78 | 8.28 | 8.78 | 9.28 | 9.78 | 10.28 | 10.78 | 11.28 |

备注:每增加10行程,重量增加0.03kg。 Note: for each additional 10 strokes, the weight will increase by 0.03kg.

MR 电机外置右侧 Motor external right side

单位:Unit: mm

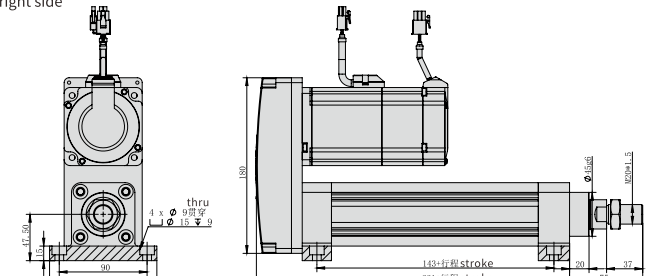

| LB 侧面安装<br>Single ear hinge | 有效行程<br>Valid stroke | 50 | 100  | 150  | 200  | 250  | 300  | 350  | 400  | 450  | 500  | 550  | 600  | 650   | 700   | 750   | 800   |
|-----------------------------|----------------------|----|------|------|------|------|------|------|------|------|------|------|------|-------|-------|-------|-------|
|                             |                      | KG | 4.53 | 5.03 | 5.53 | 6.03 | 6.53 | 7.03 | 7.53 | 8.03 | 8.53 | 9.03 | 9.53 | 10.03 | 10.53 | 11.03 | 11.53 |

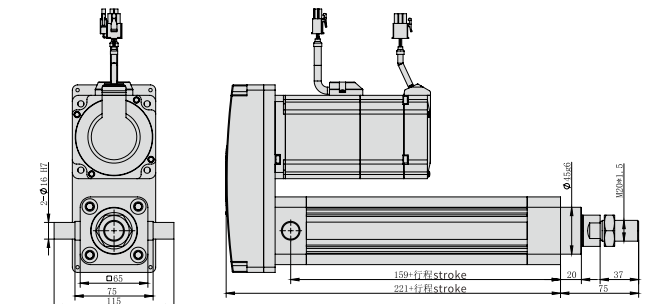

| TC 耳轴<br>Trunnion | 有效行程<br>Valid stroke | 50 | 100  | 150  | 200  | 250  | 300  | 350  | 400  | 450  | 500  | 550  | 600  | 650  | 700   | 750   | 800   |
|-------------------|----------------------|----|------|------|------|------|------|------|------|------|------|------|------|------|-------|-------|-------|
|                   |                      | KG | 4.31 | 4.81 | 5.31 | 5.81 | 6.31 | 6.81 | 7.31 | 7.81 | 8.31 | 8.81 | 9.31 | 9.81 | 10.31 | 10.81 | 11.31 |

备注:每增加10行程,重量增加0.03kg。 Note: for each additional 10 strokes, the weight will increase by 0.03kg.

- HNR
- HCR
- HNB
- HCB
- HNT
- XYZ
- ONB
- OCB
- GCR
- GCB
- GCBS
- GCRS
- ESR**
- EMR**
- EHR**
- KSR
- LNP
- DDR
- 参考资料  
Reference data

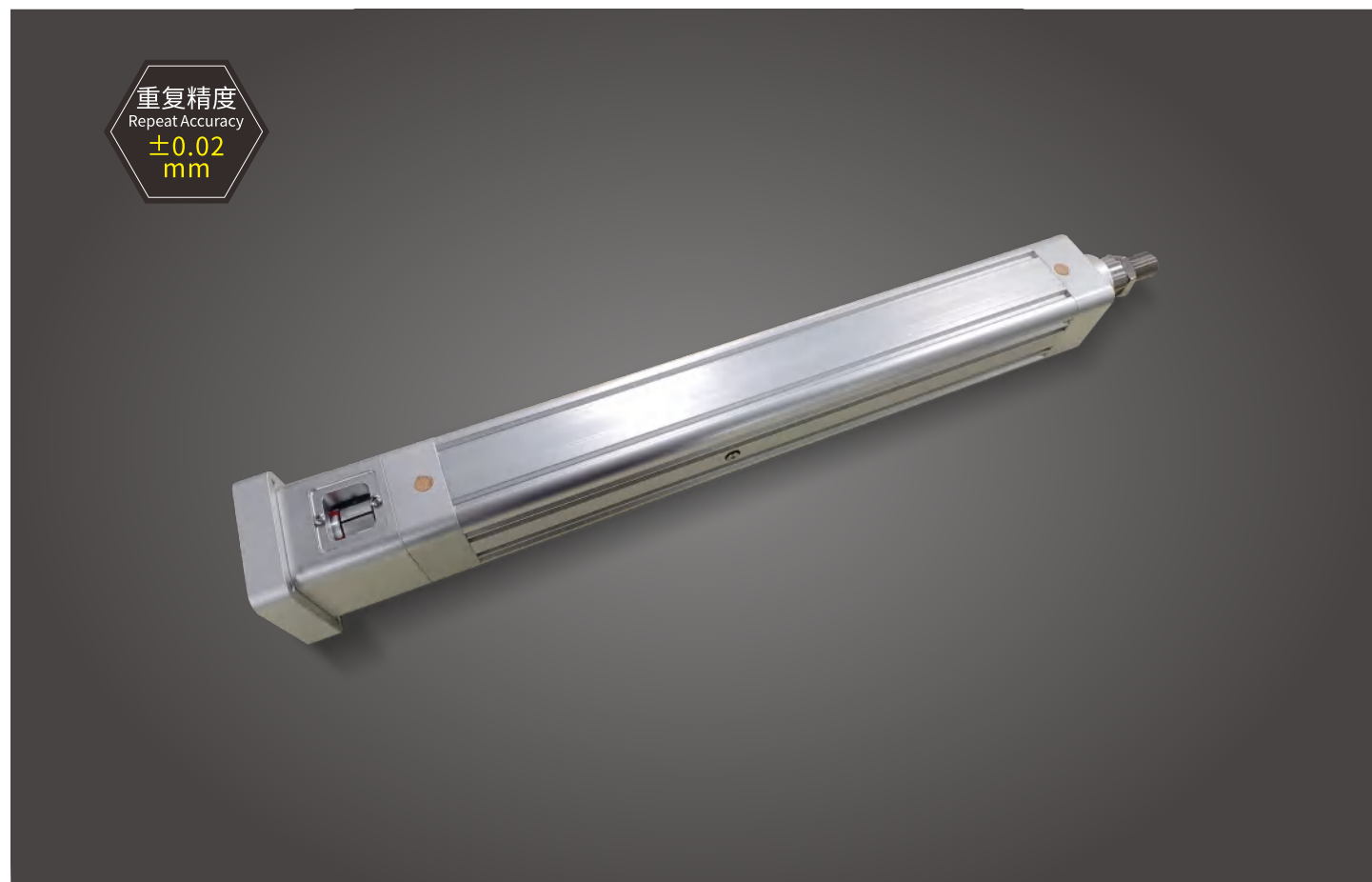

重复精度  
Repeat Accuracy  
±0.02  
mm

此图仅供参考, 出货规格详见尺寸图面  
This picture for reference only, specs details according with the drawing.

最大行程  
Max Stroke 1000mm

最高速度  
Max Speed 500mm/s

电机额定功率  
Rated power of motor 750W

滚珠螺杆  
Ball screw Ø20mm

型号表达方式 Ordering method

TPA-ESR-63-2010C-L650-M-FA-W-P40B-J3-C3-F

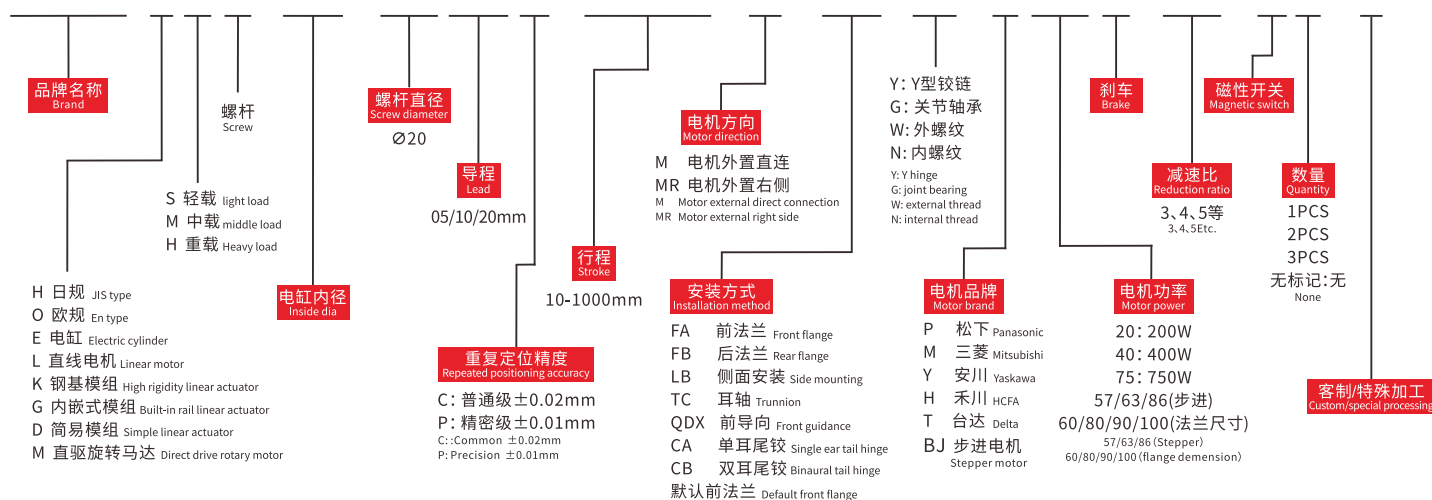

产品性能参数如下 Product performance parameters are as follows

|  |  |      |      |      |
|--|--|------|------|------|
| 电机功率 (W) Motor power (W)                       | 400  | 750  | 1000 | 1500 |
| 额定扭矩 (N.m) Rated torque (N.m)                  | 1.27   | 2.39 | 3.18 | 4.78 |
| 重复定位精度 (mm) Repeated positioning accuracy (mm) | ±0.02  |      |      |      |
| 滚珠螺杆导程 (mm) Ball screw lead (mm)               | 5  | 10   | 5    | 10   |
| 最高速度 (mm/s) Max speed (mm/s)                   | 250  | 500  | 250  | 500  |
| 电机额定转速 (RPM) Rated speed of motor (RPM)        | 3000   |      |      |      |
| 最大可搬重量 (KG) Maximum Payload (kg)               | 500kg  |      |      |      |
| 传动方式 Drive method                              | 滚珠螺杆C7转造/C5研磨 (默认C7)<br>Ball screw C7 conversion /C5 grinding (default C7) |      |      |      |
| 额定推力 (N) Rated thrust (N)                      | 1360   | 680  | 2550 | 1275 |
| 有效行程 (mm) Valid stroke (mm)                    | 10~1000mm  |      |      |      |
| 滚珠螺杆外径 (mm) Ball screw Ø (mm)                  | Ø20  |      |      |      |
| 减速机 Reducer                                    | 速比3/4/5/6/7/8/10..... Speed ratio  |      |      |      |
| 外部材质 External material                         | 铝型材 Aluminium profile  |      |      |      |
| 开关 Switch                                      | 磁感应开关 Magnetic switch  |      |      |      |
| 使用环境 Operating environment                     | -10~70°C, 85%RH (无凝露) No condensation                                      |      |      |      |

※注1: 如需增加减速机, 电缸推力, 请咨询TPA.  
Note 1: If you need to increase the thrust of reducer and electric cylinder, please consult TPA.

感应器连接图<原点及端点> Sensor layout

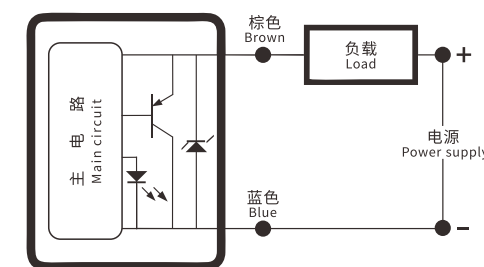

搭配伺服马达一览表 Suitable motor brand

| 伺服电机外形尺寸 servo motor size |               |               |  |  |       |     |    |     |     |     |     |    |    |     |      |      |        |        |   |
|---------------------------|---------------|---------------|--|--|-------|-----|----|-----|-----|-----|-----|----|----|-----|------|------|--------|--------|---|
| 功率 Power (w)              | 品牌 Brand      | 型号 Model      | LL   | LL(刹车) LL(Brake)                           | LA    | LE  | LZ | LC  | LG  | LW  | RH  | W  | LR | S   | LB   | M    | QK     | QL     |   |
| 400W                      | 三菱 Mitsubishi | HC-KFS43□K    | B: 带刹车 □: 无刹车<br>B: With brake □: No brake | 124.5                                      | 165.5 | 70  | 3  | 5.8 | 62  | 7   | -   | -  | -  | 30  | 14h6 | 50h7 | -      | -      | - |
|                           |               | 松下 Panasonic  | MSMJ042G1□                                 | V: 带刹车 U: 无刹车<br>V: With brake U: No brake | 99    | 135 | 70 | 3   | 4.5 | 60  | 6.5 | 20 | 11 | 5h9 | 30   | 14h6 | 50h7   | M5x10L | - |
|                           | 台达 Delta      | ECMA-C20604□S | S: 带刹车 R: 无刹车<br>S: With brake R: No brake | 130.7                                      | 166.6 | 70  | 3  | 5.5 | 60  | 7.5 | 20  | 11 | 5  | 30  | 14h6 | 70h7 | M4x15L | -      | - |
|                           |               | ECMA-C20804□S | S: 带刹车 R: 无刹车<br>S: With brake R: No brake | 112.3                                      | 152.8 | 90  | 3  | 6.6 | 80  | 8   | 20  | 11 | 5  | 35  | 14h6 | 50h7 | M4x15L | -      | - |

前端连接方式 Front end connection mode

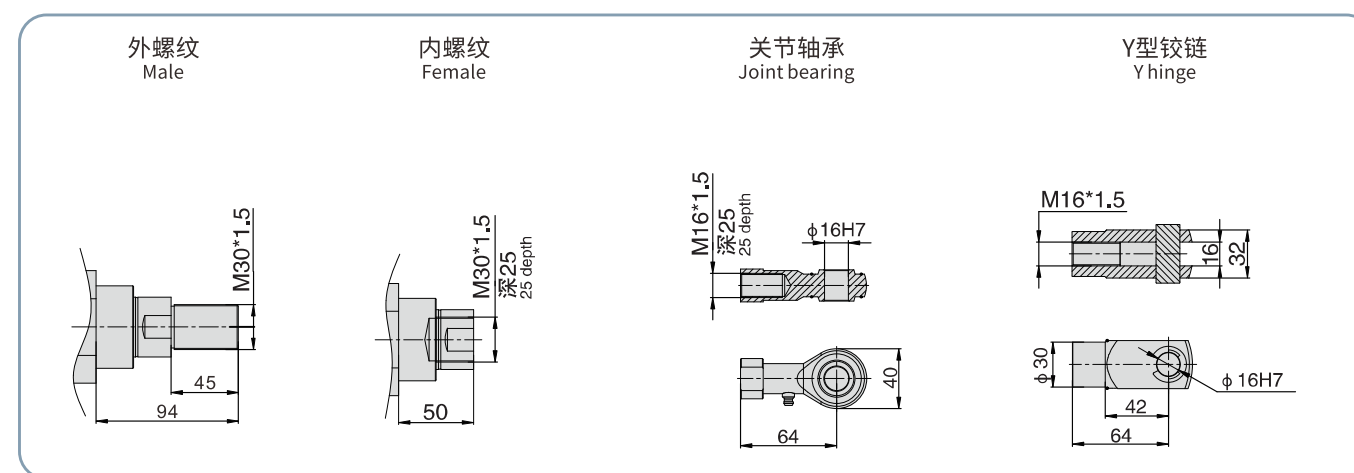

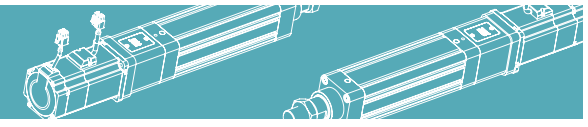

电机外置直连/电机外置右侧  
Motor external direct connection/Motor external right side

M 电机外置直连 Motor external direct connection 单位:Unit: mm

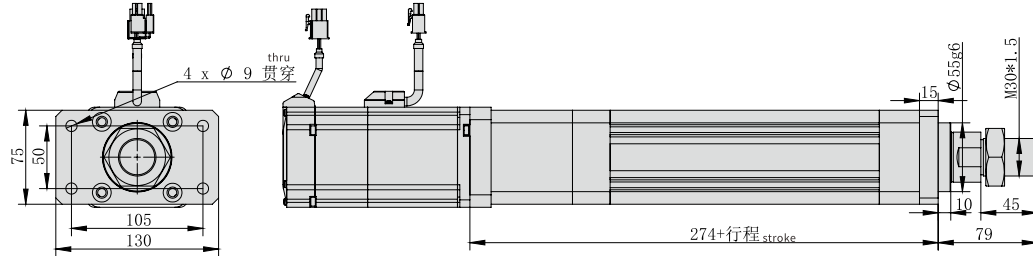

| FA 前法兰<br>Front flange | 有效行程<br>Valid stroke | 100  | 200  | 300  | 400   | 500   | 600   | 700   | 800   | 900   | 1000  |
|------------------------|----------------------|------|------|------|-------|-------|-------|-------|-------|-------|-------|
|                        | KG                   | 7.56 | 8.76 | 9.96 | 11.16 | 12.36 | 13.56 | 14.76 | 15.96 | 17.16 | 18.36 |

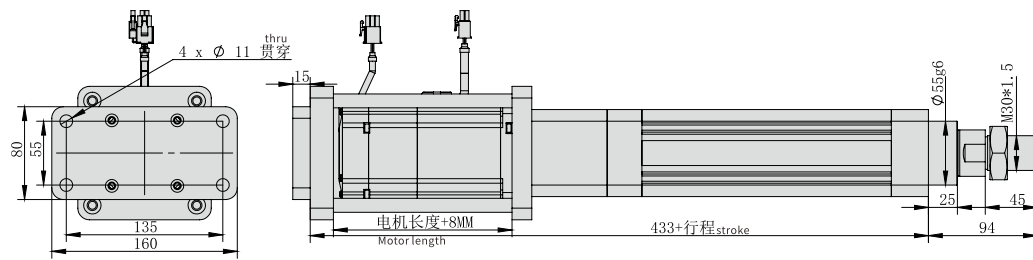

| FB 后法兰<br>Rear flange | 有效行程<br>Valid stroke | 100  | 200  | 300   | 400   | 500   | 600   | 700   | 800   | 900   | 1000  |
|-----------------------|----------------------|------|------|-------|-------|-------|-------|-------|-------|-------|-------|
|                       | KG                   | 8.52 | 9.72 | 10.92 | 12.12 | 13.32 | 14.52 | 15.72 | 16.92 | 18.12 | 19.32 |

备注:每增加10行程,重量增加0.03kg。 Note: for each additional 10 strokes, the weight will increase by 0.03kg.

M 电机外置直连 Motor external direct connection 单位:Unit: mm

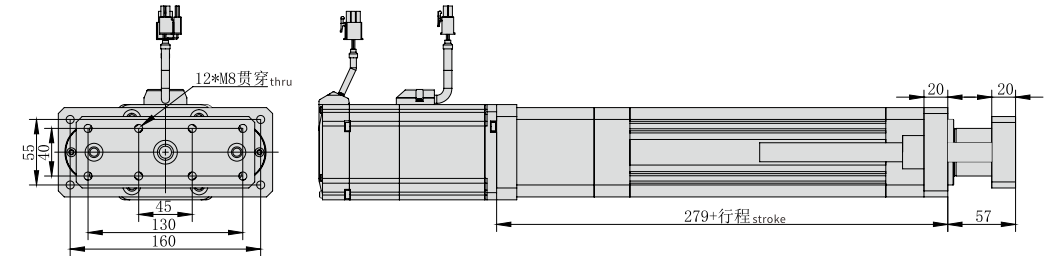

| QDX 前导向<br>Front guidance | 有效行程<br>Valid stroke | 100  | 200  | 300   | 400   | 500   | 600   | 700   | 800   | 900   | 1000  |
|---------------------------|----------------------|------|------|-------|-------|-------|-------|-------|-------|-------|-------|
|                           | KG                   | 8.24 | 9.44 | 10.64 | 11.84 | 13.04 | 14.24 | 15.44 | 16.64 | 17.84 | 19.04 |

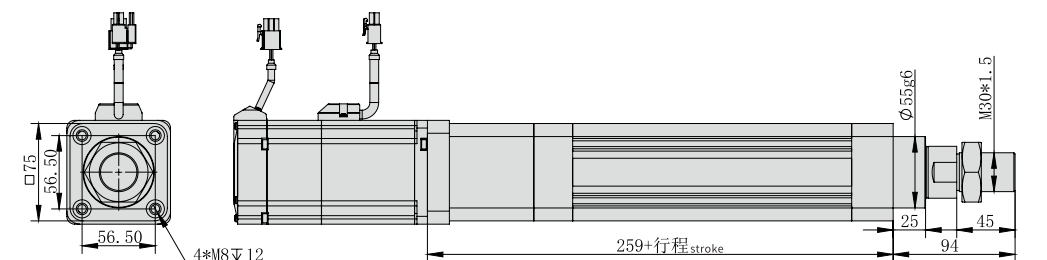

| 前端盖<br>Front end cover | 有效行程<br>Valid stroke | 100  | 200  | 300  | 400   | 500   | 600   | 700   | 800   | 900   | 1000  |
|------------------------|----------------------|------|------|------|-------|-------|-------|-------|-------|-------|-------|
|                        | KG                   | 7.30 | 8.50 | 9.70 | 10.90 | 12.10 | 13.30 | 14.50 | 15.70 | 16.90 | 18.10 |

备注:每增加10行程,重量增加0.03kg。 Note: for each additional 10 strokes, the weight will increase by 0.03kg.

M 电机外置直连 Motor external direct connection 单位:Unit: mm

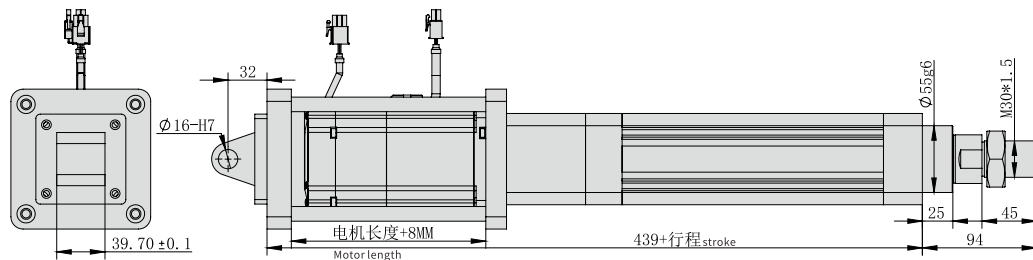

| CA 单耳尾铰<br>Single ear hinge | 有效行程<br>Valid stroke | 100  | 200   | 300   | 400   | 500   | 600   | 700   | 800   | 900   | 1000  |
|-----------------------------|----------------------|------|-------|-------|-------|-------|-------|-------|-------|-------|-------|
|                             | KG                   | 8.91 | 10.11 | 11.31 | 12.51 | 13.71 | 14.91 | 16.11 | 17.31 | 18.51 | 19.71 |

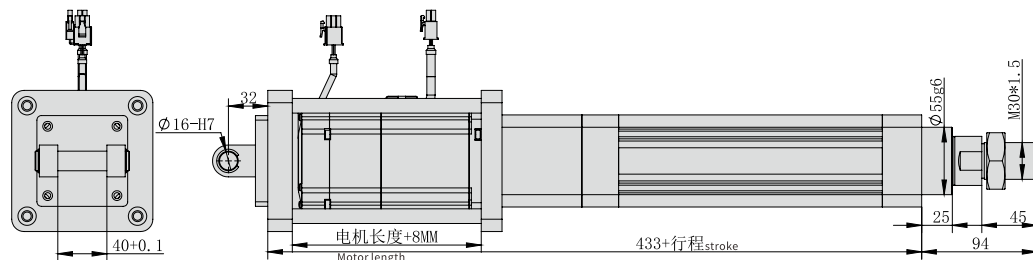

| CB 双耳尾铰<br>Ears end hinged | 有效行程<br>Valid stroke | 100  | 200   | 300   | 400   | 500   | 600   | 700   | 800   | 900   | 1000  |
|----------------------------|----------------------|------|-------|-------|-------|-------|-------|-------|-------|-------|-------|
|                            | KG                   | 8.89 | 10.09 | 11.29 | 12.49 | 13.69 | 14.89 | 16.09 | 17.29 | 18.49 | 19.69 |

备注:每增加10行程,重量增加0.03kg。 Note: for each additional 10 strokes, the weight will increase by 0.03kg.

M 电机外置直连 Motor external direct connection 单位:Unit: mm

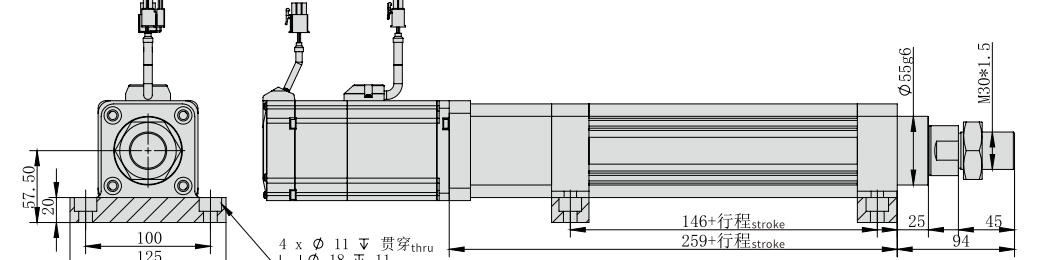

| LB 侧面安装<br>Single ear hinge | 有效行程<br>Valid stroke | 100  | 200  | 300   | 400   | 500   | 600   | 700   | 800   | 900   | 1000  |
|-----------------------------|----------------------|------|------|-------|-------|-------|-------|-------|-------|-------|-------|
|                             | KG                   | 7.68 | 8.88 | 10.08 | 11.28 | 12.48 | 13.68 | 14.88 | 16.08 | 17.28 | 18.48 |

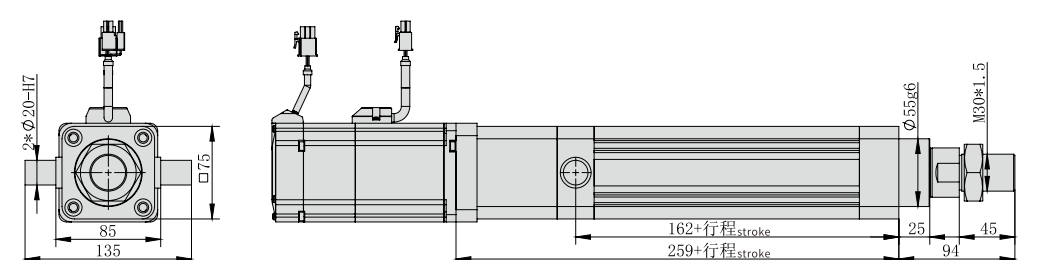

| TC 耳轴<br>Trunnion | 有效行程<br>Valid stroke | 100  | 200  | 300  | 400   | 500   | 600   | 700   | 800   | 900   | 1000  |
|-------------------|----------------------|------|------|------|-------|-------|-------|-------|-------|-------|-------|
|                   | KG                   | 7.52 | 8.72 | 9.92 | 11.12 | 12.32 | 13.52 | 14.72 | 15.92 | 17.12 | 18.32 |

备注:每增加10行程,重量增加0.03kg。 Note: for each additional 10 strokes, the weight will increase by 0.03kg.

- HNR
- HCR
- HNB
- HCB
- HNT
- XYZ
- ONB
- OCB
- GCR
- GCB
- GCBS
- GCRS
- ESR**
- EMR
- EHR
- KSR
- LNP
- DDR
- 参考资料  
Reference data

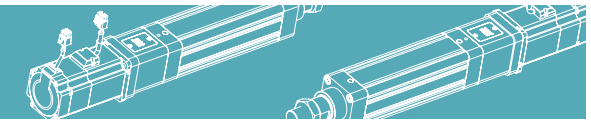

电机外置直连/电机外置右侧  
Motor external direct connection/Motor external right side

MR 电机外置右侧 Motor external right side

单位:Unit: mm

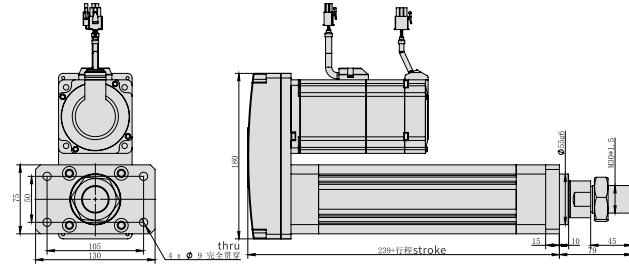

| FA 前法兰<br>Front flange | 有效行程<br>Valid stroke | 100 | 200  | 300  | 400   | 500   | 600   | 700   | 800   | 900   | 1000  |
|------------------------|----------------------|-----|------|------|-------|-------|-------|-------|-------|-------|-------|
|                        | KG                   |     | 8.76 | 9.96 | 11.16 | 12.36 | 13.56 | 14.76 | 15.96 | 17.16 | 18.36 |

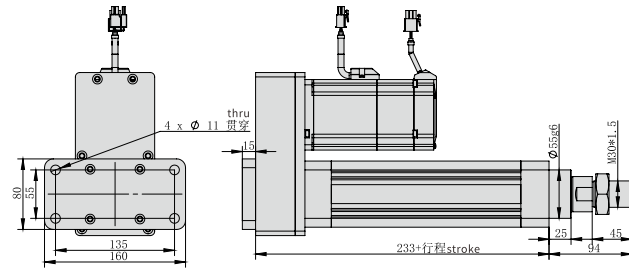

| FB 后法兰<br>Rear flange | 有效行程<br>Valid stroke | 100 | 200  | 300   | 400   | 500   | 600   | 700   | 800   | 900   | 1000  |
|-----------------------|----------------------|-----|------|-------|-------|-------|-------|-------|-------|-------|-------|
|                       | KG                   |     | 8.80 | 10.00 | 11.20 | 12.40 | 13.60 | 14.80 | 16.00 | 17.20 | 18.40 |

备注:每增加10行程,重量增加0.03kg。 Note: for each additional 10 strokes, the weight will increase by 0.03kg.

MR 电机外置右侧 Motor external right side

单位:Unit: mm

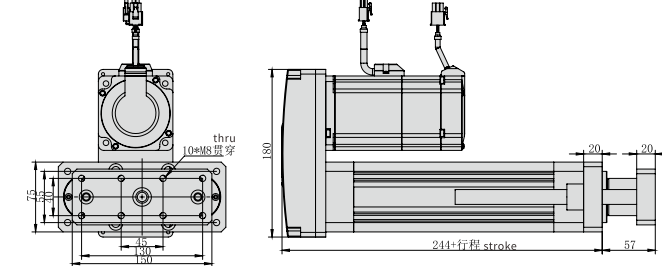

| QDX 前导向<br>Front guidance | 有效行程<br>Valid stroke | 100 | 200  | 300   | 400   | 500   | 600   | 700   | 800   | 900   | 1000  |
|---------------------------|----------------------|-----|------|-------|-------|-------|-------|-------|-------|-------|-------|
|                           | KG                   |     | 9.54 | 10.74 | 11.94 | 13.14 | 14.34 | 15.54 | 16.74 | 17.94 | 19.14 |

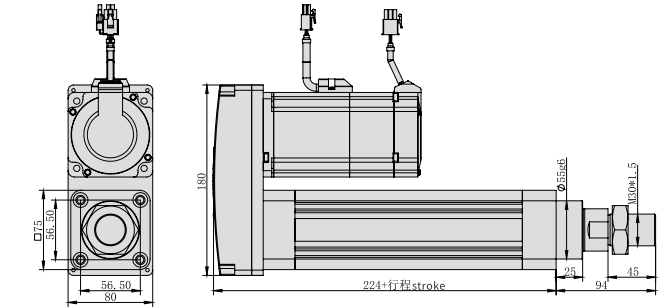

| 前端盖<br>Front cover | 有效行程<br>Valid stroke | 100 | 200  | 300  | 400   | 500   | 600   | 700   | 800   | 900   | 1000  |
|--------------------|----------------------|-----|------|------|-------|-------|-------|-------|-------|-------|-------|
|                    | KG                   |     | 8.50 | 9.70 | 10.90 | 12.10 | 13.30 | 14.50 | 15.70 | 16.90 | 18.10 |

备注:每增加10行程,重量增加0.03kg。 Note: for each additional 10 strokes, the weight will increase by 0.03kg.

MR 电机外置右侧 Motor external right side

单位:Unit: mm

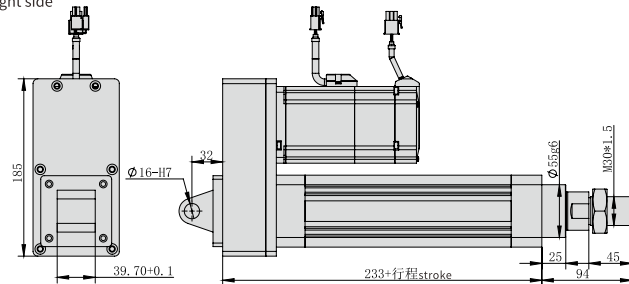

| CA 单耳尾铰<br>Single ear hinge | 有效行程<br>Valid stroke | 100 | 200  | 300   | 400   | 500   | 600   | 700   | 800   | 900   | 1000  |
|-----------------------------|----------------------|-----|------|-------|-------|-------|-------|-------|-------|-------|-------|
|                             | KG                   |     | 9.10 | 10.30 | 11.50 | 12.70 | 13.90 | 15.10 | 16.30 | 17.50 | 18.70 |

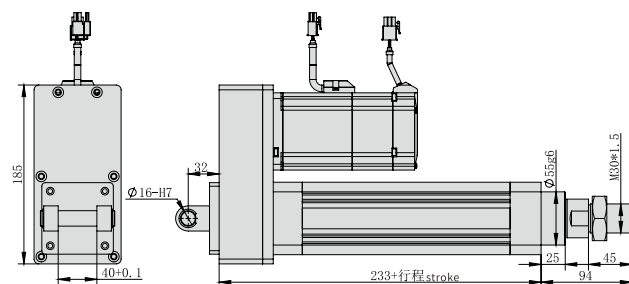

| CB 双耳尾铰<br>Ears end hinged | 有效行程<br>Valid stroke | 100 | 200  | 300   | 400   | 500   | 600   | 700   | 800   | 900   | 1000  |
|----------------------------|----------------------|-----|------|-------|-------|-------|-------|-------|-------|-------|-------|
|                            | KG                   |     | 9.00 | 10.20 | 11.40 | 12.60 | 13.80 | 15.00 | 16.20 | 17.40 | 18.60 |

备注:每增加10行程,重量增加0.03kg。 Note: for each additional 10 strokes, the weight will increase by 0.03kg.

MR 电机外置右侧 Motor external right side

单位:Unit: mm

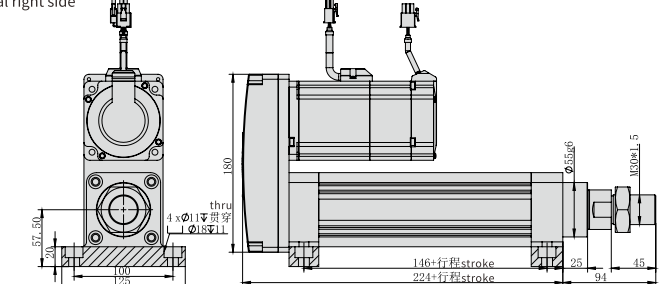

| LB 侧面安装<br>Single ear hinge | 有效行程<br>Valid stroke | 100 | 200  | 300   | 400   | 500   | 600   | 700   | 800   | 900   | 1000  |
|-----------------------------|----------------------|-----|------|-------|-------|-------|-------|-------|-------|-------|-------|
|                             | KG                   |     | 8.88 | 10.08 | 11.28 | 12.48 | 13.68 | 14.88 | 16.08 | 17.28 | 18.48 |

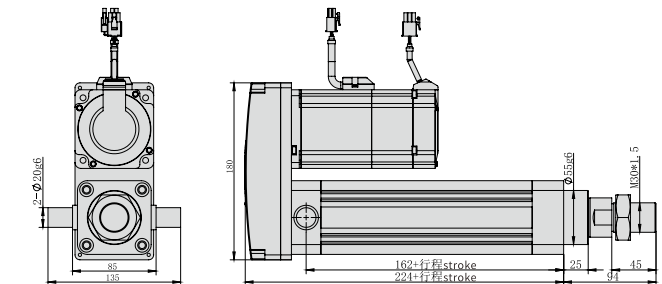

| TC 耳轴<br>Trunnion | 有效行程<br>Valid stroke | 100 | 200  | 300  | 400   | 500   | 600   | 700   | 800   | 900   | 1000  |
|-------------------|----------------------|-----|------|------|-------|-------|-------|-------|-------|-------|-------|
|                   | KG                   |     | 8.72 | 9.92 | 11.12 | 12.32 | 13.52 | 14.72 | 15.92 | 17.12 | 18.32 |

备注:每增加10行程,重量增加0.03kg。 Note: for each additional 10 strokes, the weight will increase by 0.03kg.

- HNR
- HCR
- HNB
- HCB
- HNT
- XYZ
- ONB
- OCB
- GCR
- GCB
- GCBS
- GCRS
- ESR**
- EMR
- EHR
- KSR
- LNP
- DDR
- 参考资料  
Reference data

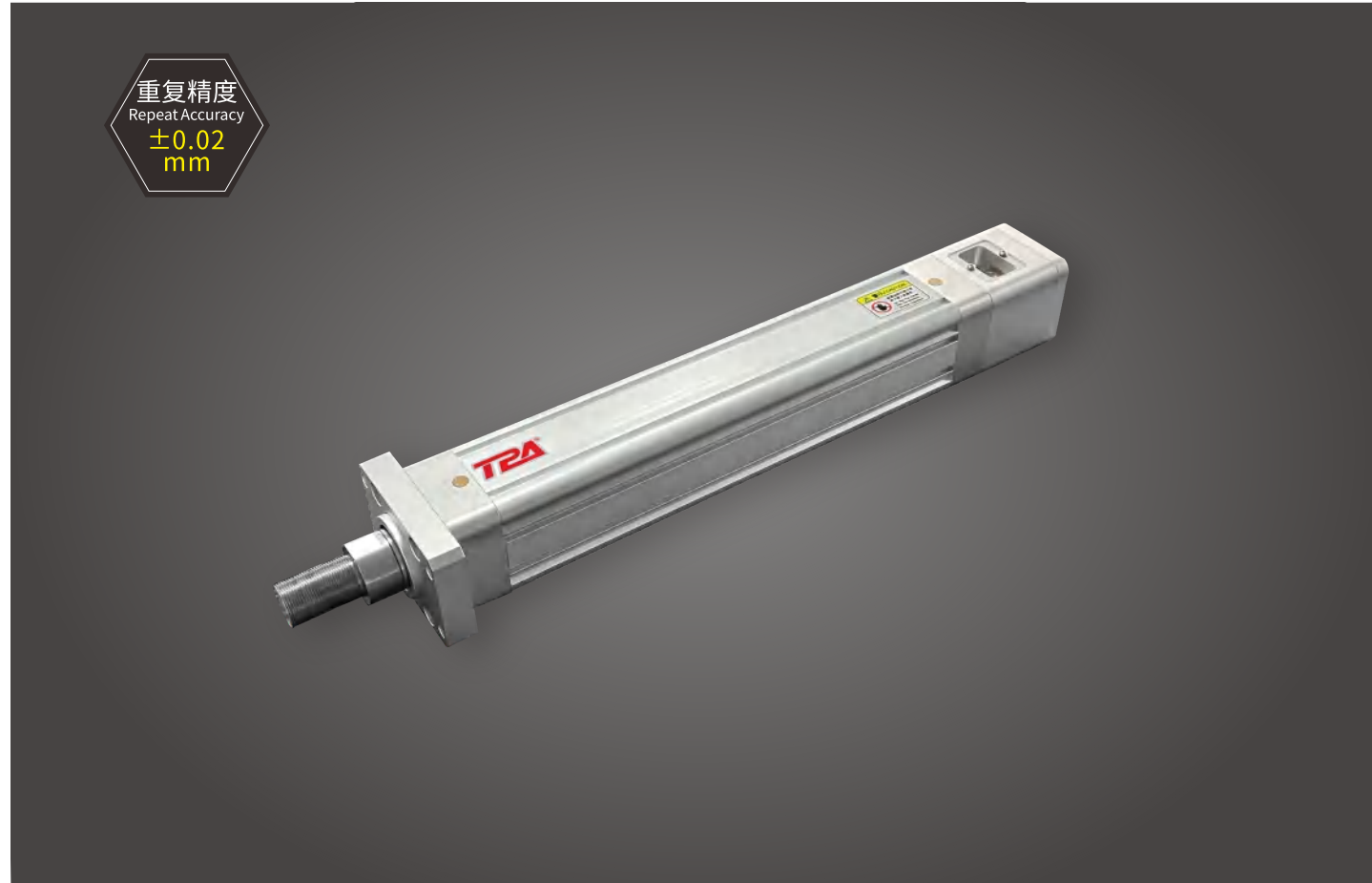
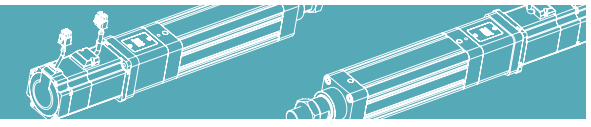

重复精度  
Repeat Accuracy  
±0.02  
mm

此图仅供参考, 出货规格详见尺寸图面  
This picture for reference only, specs details according with the drawing.

最大行程  
Max Stroke 1500mm

最高速度  
Max Speed 500mm/s

电机额定功率  
Rated power of motor 750W

滚珠螺杆  
Ball screw Ø25mm

型号表达方式 Ordering method

TPA-ESR-80-2505C-L200-M-FA-W-P75B-J3-C3-F

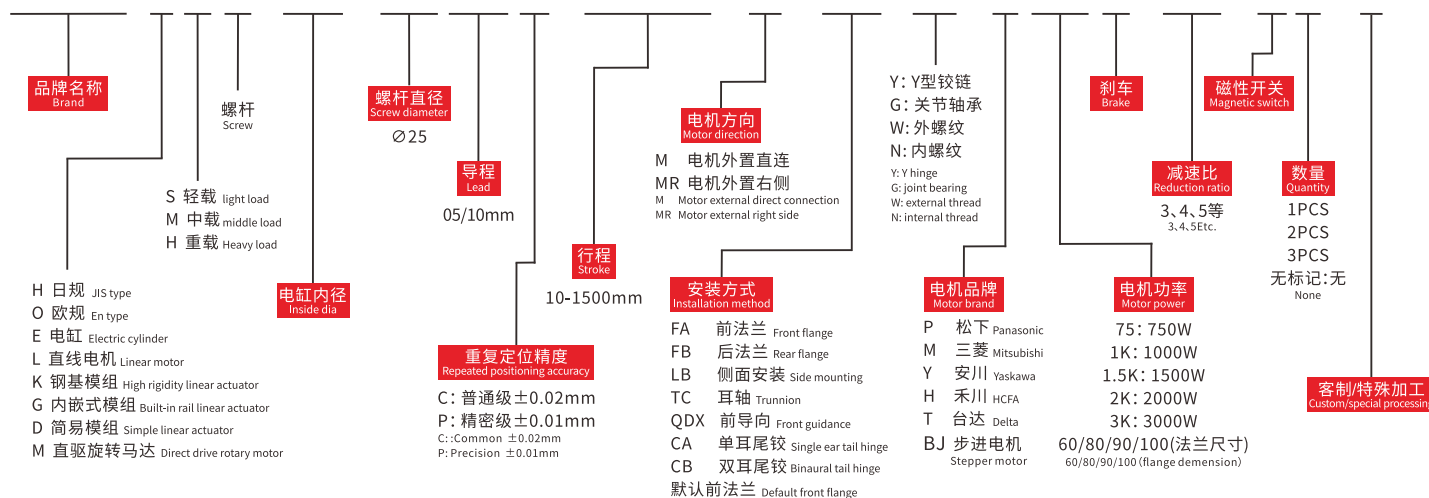

产品性能参数如下 Product performance parameters are as follows

|                            |  |  |      |      |      |
|----------------------------|--|--|------|------|------|
| 规格 Spec                    | 电机功率 (W) Motor power (W)                       | 750  | 1000 | 1500 | 2000 |
|                            | 额定扭矩 (N.m) Rated torque (N.m)                  | 2.39   | 3.18 | 4.78 | 6.37 |
|                            | 重复定位精度 (mm) Repeated positioning accuracy (mm) | ±0.02  |      |      |      |
|                            | 滚珠螺杆导程 (mm) Ball screw lead (mm)               | 5  | 10   | 5    | 10   |
|                            | 最高速度 (mm/s) Max speed (mm/s)                   | 250  | 500  | 250  | 500  |
|                            | 电机额定转速 (RPM) Rated speed of motor (RPM)        | 3000   |      |      |      |
|                            | 最大可搬重量 (KG) Maximum Payload (kg)               | 1T   |      |      |      |
|                            | 传动方式 Drive method                              | 滚珠螺杆C7转造/C5研磨 (默认C7)<br>Ball screw C7 conversion /C5 grinding (default C7) |      |      |      |
|                            | 额定推力 (N) Rated thrust (N)                      | 2550   | 1275 | 3400 | 1700 |
|                            | 有效行程 (mm) Valid stroke (mm)                    | 10~1500mm  |      |      |      |
| 部品 Parts                   | 滚珠螺杆外径 (mm) Ball screw Ø (mm)                  | Ø25  |      |      |      |
|                            | 减速机 Reducer                                    | 速比3/4/5/6/7/8/10..... Speed ratio  |      |      |      |
|                            | 外部材质 External material                         | 铝型材 Aluminium profile  |      |      |      |
|                            | 开关 Switch                                      | 磁感应开关 Magnetic switch  |      |      |      |
| 使用环境 Operating environment | -10~70°C, 85%RH (无凝露) No condensation          |  |      |      |      |

※注1: 如需增加减速机, 电缸推力, 请咨询TPA.  
Note 1: If you need to increase the thrust of reducer and electric cylinder, please consult TPA.

感应器连接图<原点及端点> Sensor layout

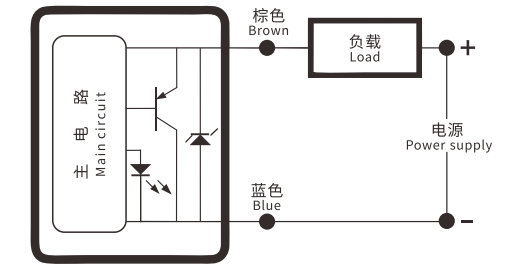

搭配伺服马达一览表 Suitable motor brand

| 伺服电机外形尺寸 servo motor size |               |               |  |                  |       |    |    |     |    |     |    |    |     |    |      |      |        |    |   |
|---------------------------|---------------|---------------|--|------------------|-------|----|----|-----|----|-----|----|----|-----|----|------|------|--------|----|---|
| 功率 Power (w)              | 品牌 Brand      | 型号 Model      | LL   | LL(刹车) LL(Brake) | LA    | LE | LZ | LC  | LG | LW  | RH | W  | LR  | S  | LB   | M    | QK     | QL |   |
| 400W                      | 三菱 Mitsubishi | HC-KFS43□K    | B: 带刹车 □: 无刹车<br>B: With brake □: No brake | 124.5            | 165.5 | 70 | 3  | 5.8 | 62 | 7   | -  | -  | -   | 30 | 14h6 | 50h7 | -      | -  | - |
|                           | 松下 Panasonic  | MSMJ042G1□    | V: 带刹车 U: 无刹车<br>V: With brake U: No brake | 99               | 135   | 70 | 3  | 4.5 | 60 | 6.5 | 20 | 11 | 5h9 | 30 | 14h6 | 50h7 | M5x10L | -  | - |
|                           | 台达 Delta      | ECMA-C20604□S | S: 带刹车 R: 无刹车<br>S: With brake R: No brake | 130.7            | 166.6 | 70 | 3  | 5.5 | 60 | 7.5 | 20 | 11 | 5   | 30 | 14h6 | 70h7 | M4x15L | -  | - |
|                           |               | ECMA-C20804□S | S: 带刹车 R: 无刹车<br>S: With brake R: No brake | 112.3            | 152.8 | 90 | 3  | 6.6 | 80 | 8   | 20 | 11 | 5   | 35 | 14h6 | 50h7 | M4x15L | -  | - |

前端连接方式 Front end connection mode

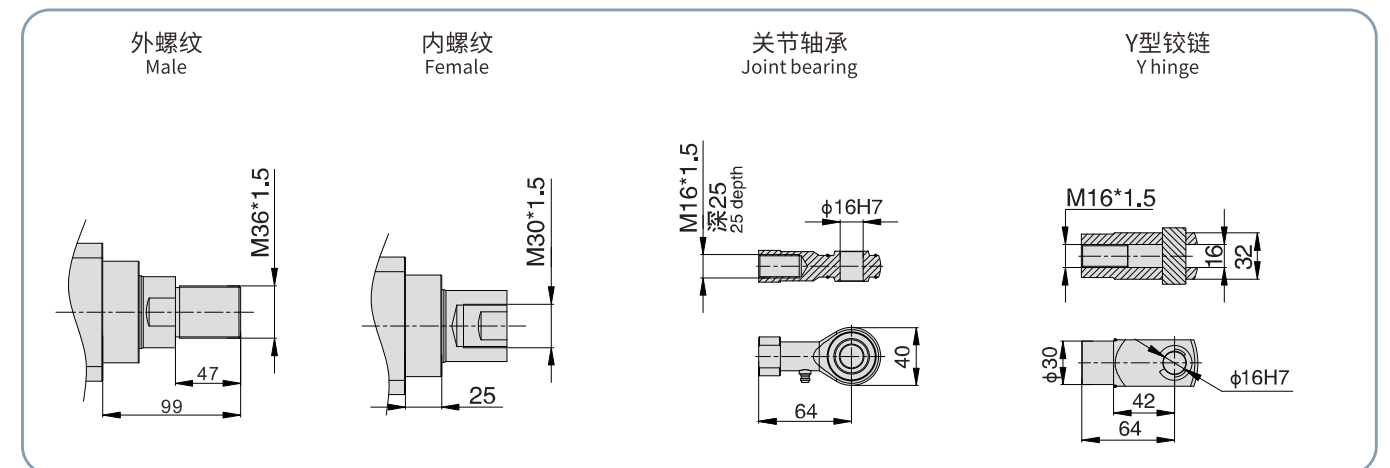

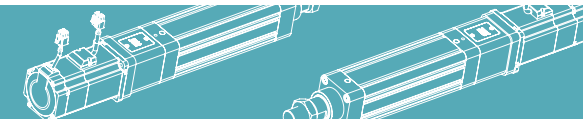

电机外置直连/电机外置右侧  
Motor external direct connection/Motor external right side

M 电机外置直连 Motor external direct connection

单位:Unit: mm

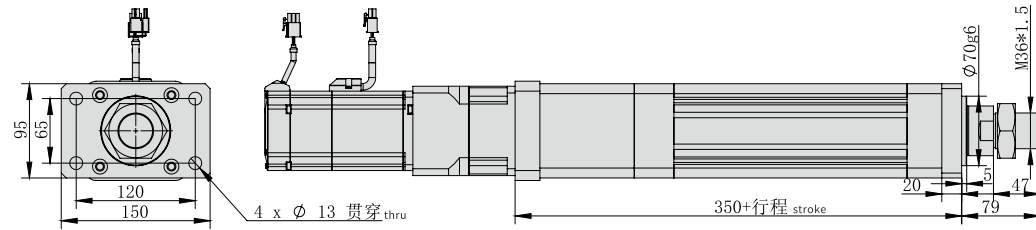

| FA 前法兰<br>Front flange | 有效行程<br>Valid stroke | 100   | 200   | 300   | 400   | 500   | 600   | 700   | 800   | 900   | 1000  | 1100  | 1200  | 1300  | 1400  | 1500  |
|------------------------|----------------------|-------|-------|-------|-------|-------|-------|-------|-------|-------|-------|-------|-------|-------|-------|-------|
|                        | KG                   | 13.67 | 15.57 | 17.47 | 19.37 | 21.27 | 23.17 | 25.07 | 26.97 | 28.87 | 30.77 | 32.67 | 34.57 | 36.47 | 38.37 | 40.27 |

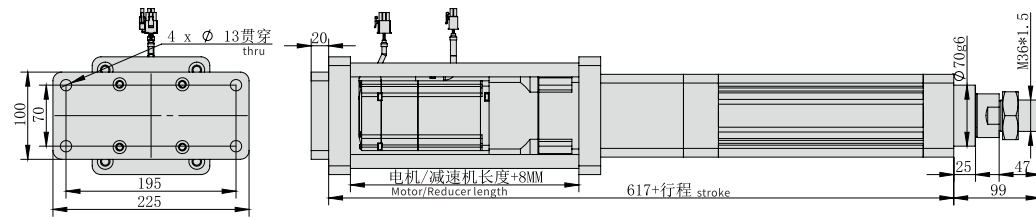

| FB 后法兰<br>Rear flange | 有效行程<br>Valid stroke | 100   | 200   | 300   | 400   | 500   | 600   | 700   | 800   | 900   | 1000  | 1100  | 1200  | 1300  | 1400  | 1500  |
|-----------------------|----------------------|-------|-------|-------|-------|-------|-------|-------|-------|-------|-------|-------|-------|-------|-------|-------|
|                       | KG                   | 16.80 | 18.70 | 20.60 | 22.50 | 24.40 | 26.30 | 28.20 | 30.10 | 32.00 | 33.90 | 35.80 | 37.70 | 39.60 | 41.50 | 43.40 |

备注:每增加10行程,重量增加0.03kg。 Note: for each additional 10 strokes, the weight will increase by 0.03kg.

M 电机外置直连 Motor external direct connection

单位:Unit: mm

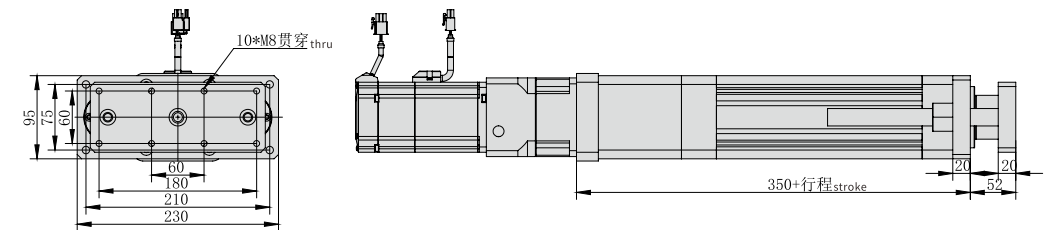

| QDX 前导向<br>Front guidance | 有效行程<br>Valid stroke | 100   | 200   | 300   | 400   | 500   | 600   | 700   | 800   | 900   | 1000  | 1100  | 1200  | 1300  | 1400  | 1500  |
|---------------------------|----------------------|-------|-------|-------|-------|-------|-------|-------|-------|-------|-------|-------|-------|-------|-------|-------|
|                           | KG                   | 15.01 | 16.91 | 18.81 | 20.71 | 22.61 | 24.51 | 26.41 | 28.31 | 30.21 | 32.11 | 34.01 | 35.91 | 37.81 | 39.71 | 41.61 |

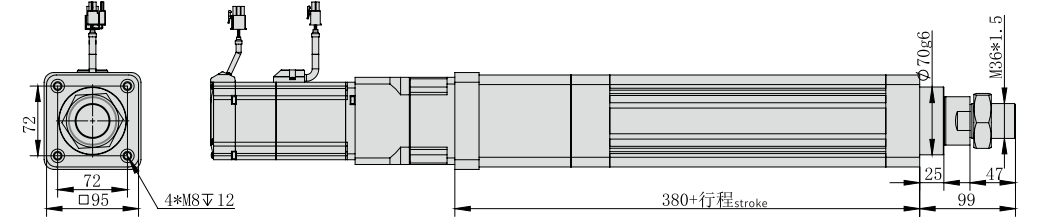

| 前端盖<br>Front end cover | 有效行程<br>Valid stroke | 100   | 200   | 300   | 400   | 500   | 600   | 700   | 800   | 900   | 1000  | 1100  | 1200  | 1300  | 1400  | 1500  |
|------------------------|----------------------|-------|-------|-------|-------|-------|-------|-------|-------|-------|-------|-------|-------|-------|-------|-------|
|                        | KG                   | 13.26 | 15.16 | 17.06 | 18.96 | 20.86 | 22.76 | 24.66 | 26.56 | 28.46 | 30.36 | 32.26 | 34.16 | 36.06 | 37.96 | 39.86 |

备注:每增加10行程,重量增加0.03kg。 Note: for each additional 10 strokes, the weight will increase by 0.03kg.

M 电机外置直连 Motor external direct connection

单位:Unit: mm

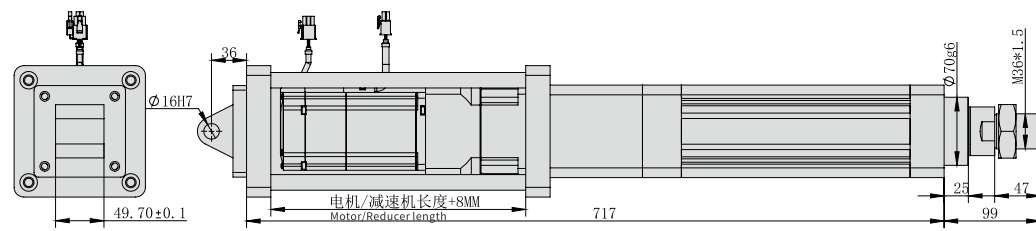

| CA 单耳尾铰<br>Single ear hinge | 有效行程<br>Valid stroke | 100   | 200   | 300   | 400   | 500   | 600   | 700   | 800   | 900   | 1000  | 1100  | 1200  | 1300  | 1400  | 1500  |
|-----------------------------|----------------------|-------|-------|-------|-------|-------|-------|-------|-------|-------|-------|-------|-------|-------|-------|-------|
|                             | KG                   | 17.54 | 19.44 | 21.34 | 23.24 | 25.14 | 27.04 | 28.94 | 30.84 | 32.74 | 34.64 | 36.54 | 38.44 | 40.34 | 42.24 | 44.14 |

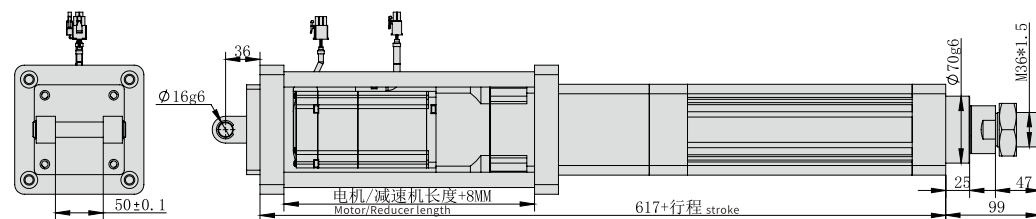

| CB 双耳尾铰<br>Ears end hinged | 有效行程<br>Valid stroke | 100   | 200   | 300   | 400   | 500   | 600   | 700   | 800   | 900   | 1000  | 1100  | 1200  | 1300  | 1400  | 1500  |
|----------------------------|----------------------|-------|-------|-------|-------|-------|-------|-------|-------|-------|-------|-------|-------|-------|-------|-------|
|                            | KG                   | 17.52 | 19.42 | 21.32 | 23.22 | 25.12 | 27.02 | 28.92 | 30.82 | 32.72 | 34.62 | 36.52 | 38.42 | 40.32 | 42.22 | 44.12 |

备注:每增加10行程,重量增加0.03kg。 Note: for each additional 10 strokes, the weight will increase by 0.03kg.

M 电机外置直连 Motor external direct connection

单位:Unit: mm

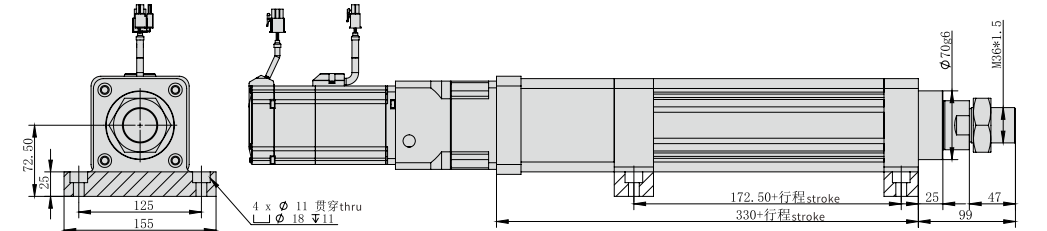

| LB 侧面安装<br>Single ear hinge | 有效行程<br>Valid stroke | 100   | 200   | 300   | 400   | 500   | 600   | 700   | 800   | 900   | 1000  | 1100  | 1200  | 1300  | 1400  | 1500  |
|-----------------------------|----------------------|-------|-------|-------|-------|-------|-------|-------|-------|-------|-------|-------|-------|-------|-------|-------|
|                             | KG                   | 13.59 | 15.49 | 17.39 | 19.29 | 21.19 | 23.09 | 24.99 | 26.89 | 28.79 | 30.69 | 32.59 | 34.49 | 36.39 | 38.29 | 40.19 |

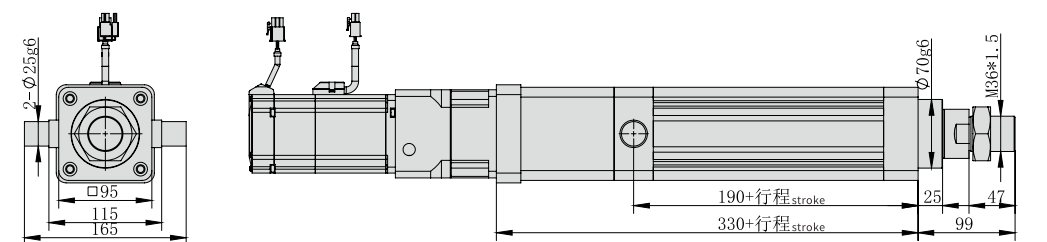

| TC 耳轴<br>Trunnion | 有效行程<br>Valid stroke | 100   | 200   | 300   | 400   | 500   | 600   | 700   | 800   | 900   | 1000  | 1100  | 1200  | 1300  | 1400  | 1500  |
|-------------------|----------------------|-------|-------|-------|-------|-------|-------|-------|-------|-------|-------|-------|-------|-------|-------|-------|
|                   | KG                   | 13.45 | 15.35 | 17.25 | 19.15 | 21.05 | 22.95 | 24.85 | 26.75 | 28.65 | 30.55 | 32.45 | 34.35 | 36.25 | 38.15 | 40.05 |

备注:每增加10行程,重量增加0.03kg。 Note: for each additional 10 strokes, the weight will increase by 0.03kg.

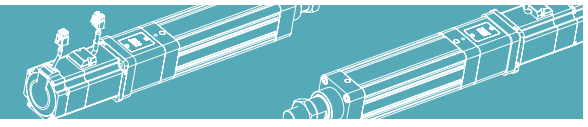

电机外置直连/电机外置右侧  
Motor external direct connection/Motor external right side

MR 电机外置右侧 Motor external right side

单位:Unit: mm

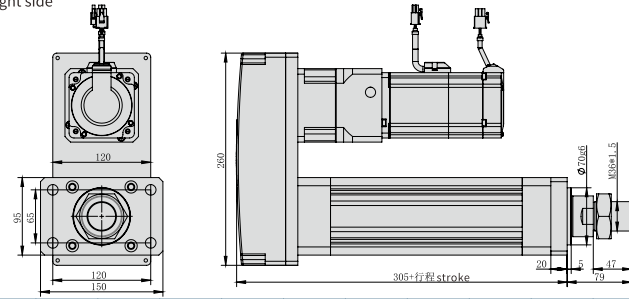

| FA 前法兰<br>Front flange | 有效行程<br>Valid stroke | 100 | 200   | 300   | 400   | 500   | 600   | 700   | 800   | 900   | 1000  | 1100  | 1200  | 1300  | 1400  | 1500  |
|------------------------|----------------------|-----|-------|-------|-------|-------|-------|-------|-------|-------|-------|-------|-------|-------|-------|-------|
|                        |                      | KG  | 14.98 | 16.88 | 18.78 | 20.68 | 22.58 | 24.48 | 26.38 | 28.28 | 30.18 | 32.08 | 33.98 | 35.88 | 37.78 | 39.68 |

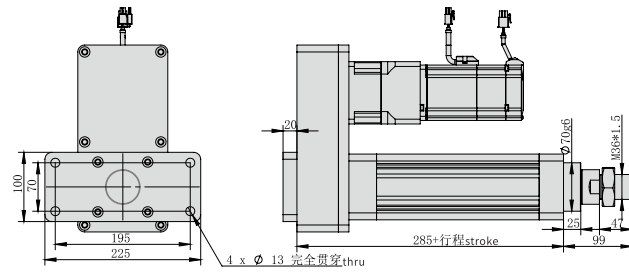

| FB 后法兰<br>Rear flange | 有效行程<br>Valid stroke | 100 | 200   | 300   | 400   | 500   | 600   | 700   | 800   | 900   | 1000  | 1100  | 1200  | 1300  | 1400  | 1500  |
|-----------------------|----------------------|-----|-------|-------|-------|-------|-------|-------|-------|-------|-------|-------|-------|-------|-------|-------|
|                       |                      | KG  | 15.00 | 16.90 | 18.80 | 20.70 | 22.60 | 24.50 | 26.40 | 28.30 | 30.20 | 32.10 | 34.00 | 35.90 | 37.80 | 39.70 |

备注:每增加10行程,重量增加0.03kg。 Note: for each additional 10 strokes, the weight will increase by 0.03kg.

MR 电机外置右侧 Motor external right side

单位:Unit: mm

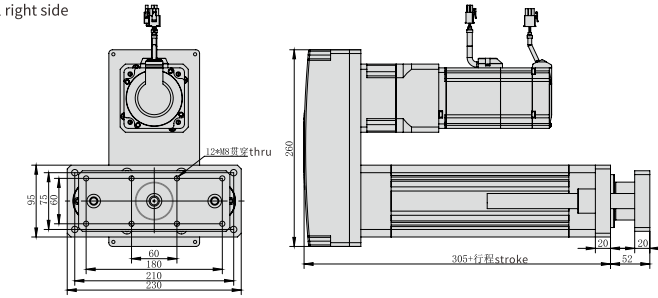

| QDX 前导向<br>Front guidance | 有效行程<br>Valid stroke | 100 | 200   | 300   | 400   | 500   | 600   | 700   | 800   | 900   | 1000  | 1100  | 1200  | 1300  | 1400  | 1500  |
|---------------------------|----------------------|-----|-------|-------|-------|-------|-------|-------|-------|-------|-------|-------|-------|-------|-------|-------|
|                           |                      | KG  | 16.30 | 18.20 | 20.10 | 22.00 | 23.90 | 25.80 | 27.70 | 29.60 | 31.50 | 33.40 | 35.30 | 37.20 | 39.10 | 41.00 |

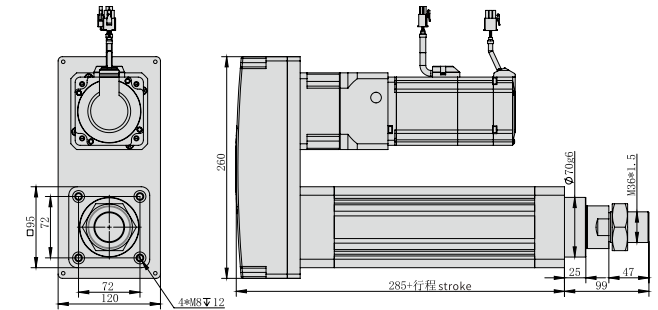

| 前端盖<br>Front end cover | 有效行程<br>Valid stroke | 100 | 200   | 300   | 400   | 500   | 600   | 700   | 800   | 900   | 1000  | 1100  | 1200  | 1300  | 1400  | 1500  |
|------------------------|----------------------|-----|-------|-------|-------|-------|-------|-------|-------|-------|-------|-------|-------|-------|-------|-------|
|                        |                      | KG  | 14.58 | 16.48 | 18.38 | 20.28 | 22.18 | 24.08 | 25.98 | 27.88 | 29.78 | 31.68 | 33.58 | 35.48 | 37.38 | 39.28 |

备注:每增加10行程,重量增加0.03kg。 Note: for each additional 10 strokes, the weight will increase by 0.03kg.

MR 电机外置右侧 Motor external right side

单位:Unit: mm

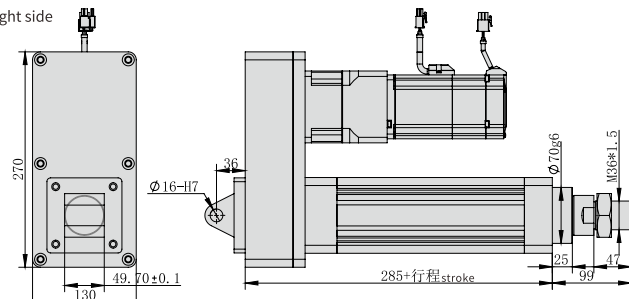

| CA 单耳尾铰<br>Single ear hinge | 有效行程<br>Valid stroke | 100 | 200   | 300   | 400   | 500   | 600   | 700   | 800   | 900   | 1000  | 1100  | 1200  | 1300  | 1400  | 1500  |
|-----------------------------|----------------------|-----|-------|-------|-------|-------|-------|-------|-------|-------|-------|-------|-------|-------|-------|-------|
|                             |                      | KG  | 15.16 | 17.06 | 18.96 | 20.86 | 22.76 | 24.66 | 26.56 | 28.46 | 30.36 | 32.26 | 34.16 | 36.06 | 37.96 | 39.86 |

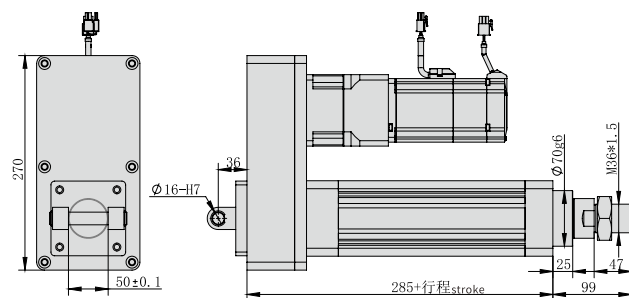

| CB 双耳尾铰<br>Ears end hinged | 有效行程<br>Valid stroke | 100 | 200   | 300   | 400   | 500   | 600   | 700   | 800   | 900   | 1000  | 1100  | 1200  | 1300  | 1400  | 1500  |
|----------------------------|----------------------|-----|-------|-------|-------|-------|-------|-------|-------|-------|-------|-------|-------|-------|-------|-------|
|                            |                      | KG  | 15.10 | 17.00 | 18.90 | 20.80 | 22.70 | 24.60 | 26.50 | 28.40 | 30.30 | 32.20 | 34.10 | 36.00 | 37.90 | 39.80 |

备注:每增加10行程,重量增加0.03kg。 Note: for each additional 10 strokes, the weight will increase by 0.03kg.

MR 电机外置右侧 Motor external right side

单位:Unit: mm

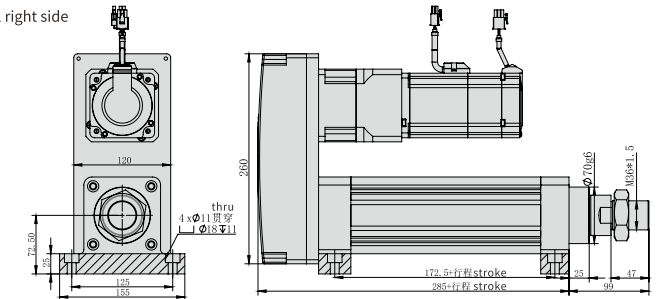

| LB 侧面安装<br>Single ear hinge | 有效行程<br>Valid stroke | 100 | 200   | 300   | 400   | 500   | 600   | 700   | 800   | 900   | 1000  | 1100  | 1200  | 1300  | 1400  | 1500  |
|-----------------------------|----------------------|-----|-------|-------|-------|-------|-------|-------|-------|-------|-------|-------|-------|-------|-------|-------|
|                             |                      | KG  | 14.90 | 16.80 | 18.70 | 20.60 | 22.50 | 24.40 | 26.30 | 28.20 | 30.10 | 32.00 | 33.90 | 35.80 | 37.70 | 39.60 |

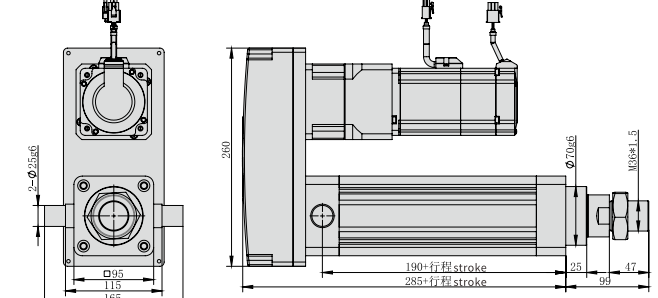

| TC 耳轴<br>Trunnion | 有效行程<br>Valid stroke | 100 | 200   | 300   | 400   | 500   | 600   | 700   | 800   | 900   | 1000  | 1100  | 1200  | 1300  | 1400  | 1500  |
|-------------------|----------------------|-----|-------|-------|-------|-------|-------|-------|-------|-------|-------|-------|-------|-------|-------|-------|
|                   |                      | KG  | 14.74 | 16.64 | 18.54 | 20.44 | 22.34 | 24.24 | 26.14 | 28.04 | 29.94 | 31.84 | 33.74 | 35.64 | 37.54 | 39.44 |

备注:每增加10行程,重量增加0.03kg。 Note: for each additional 10 strokes, the weight will increase by 0.03kg.

- HNR
- HCR
- HNB
- HCB
- HNT
- XYZ
- ONB
- OCB
- GCR
- GCB
- GCBS
- GCRS
- ESR**
- EMR
- EHR
- KSR
- LNP
- DDR
- 参考资料  
Reference data

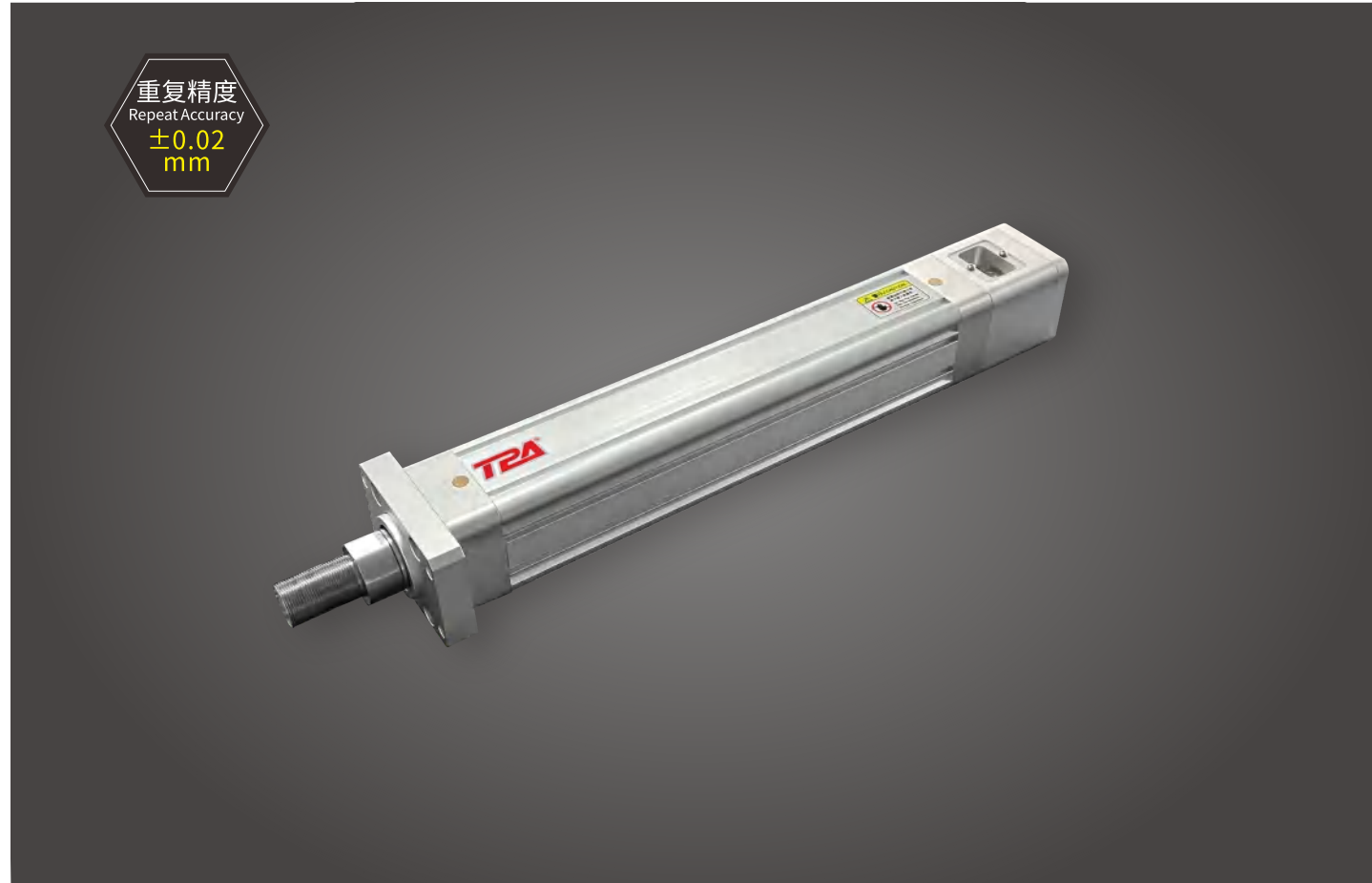
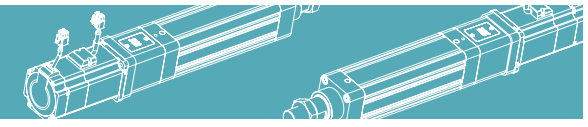

重复精度  
Repeat Accuracy  
±0.02  
mm

此图仅供参考, 出货规格详见尺寸图面  
This picture for reference only, specs details according with the drawing.

最大行程  
Max Stroke 2000mm

最高速度  
Max Speed 500mm/s

电机额定功率  
Rated power of motor 750W

滚珠螺杆  
Ball screw Ø32mm

型号表达方式 Ordering method

TPA-ESR-100-3205C-L200-M-FA-W-P10B-J3-C3-F

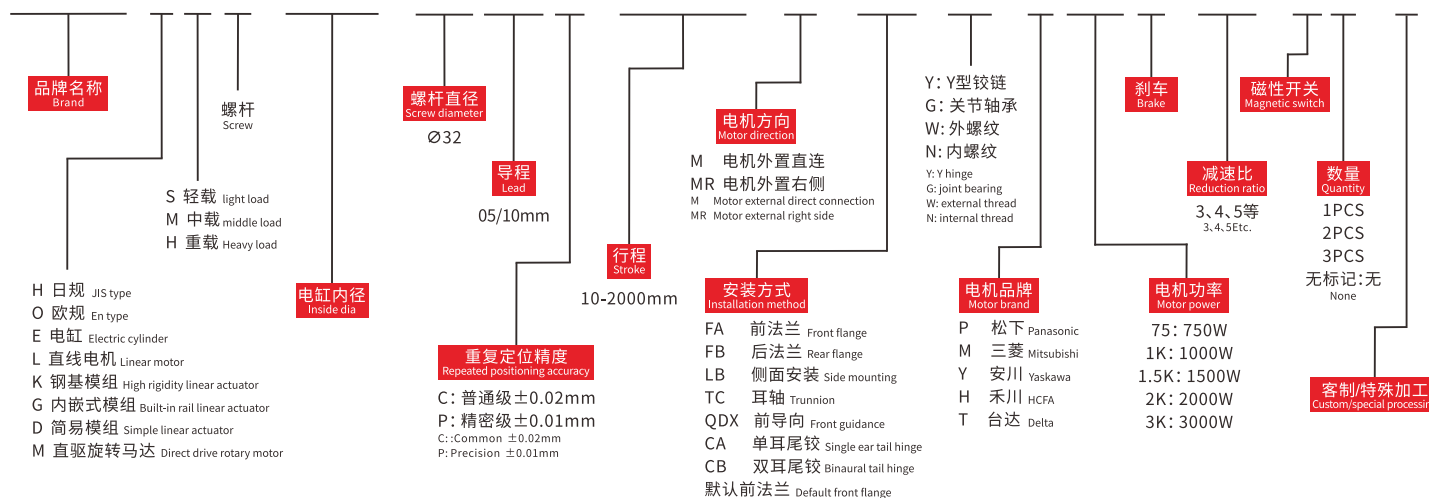

产品性能参数如下 Product performance parameters are as follows

|                            |  |  |      |      |      |
|----------------------------|--|--|------|------|------|
| 规格 Spec                    | 电机功率 (W) Motor power (W)                       | 750  | 1000 | 1500 | 2000 |
|                            | 额定扭矩 (N.m) Rated torque (N.m)                  | 2.39   | 3.18 | 4.78 | 6.37 |
|                            | 重复定位精度 (mm) Repeated positioning accuracy (mm) | ±0.02  |      |      |      |
|                            | 滚珠螺杆导程 (mm) Ball screw lead (mm)               | 5  | 10   | 5    | 10   |
|                            | 最高速度 (mm/s) Max speed (mm/s)                   | 250  | 500  | 250  | 500  |
|                            | 电机额定转速 (RPM) Rated speed of motor (RPM)        | 3000   |      |      |      |
|                            | 最大可搬重量 (KG) Maximum Payload (kg)               | 1.5T   |      |      |      |
|                            | 传动方式 Drive method                              | 滚珠螺杆C7转磨/C5研磨 (默认C7)<br>Ball screw C7 conversion /C5 grinding (default C7) |      |      |      |
|                            | 额定推力 (N) Rated thrust (N)                      | 2550   | 1275 | 3400 | 1700 |
|                            | 有效行程 (mm) Valid stroke (mm)                    | 10~2000mm  |      |      |      |
| 部品 Parts                   | 滚珠螺杆外径 (mm) Ball screw Ø (mm)                  | Ø32  |      |      |      |
|                            | 减速机 Reducer                                    | 速比3/4/5/6/7/8/10..... Speed ratio  |      |      |      |
|                            | 外部材质 External material                         | 铝型材 Aluminium profile  |      |      |      |
|                            | 开关 Switch                                      | 磁感应开关 Magnetic switch  |      |      |      |
| 使用环境 Operating environment | -10~70°C, 85%RH (无凝露) No condensation          |  |      |      |      |

※注1: 如需增加减速机, 电缸推力, 请咨询TPA.  
Note 1: If you need to increase the thrust of reducer and electric cylinder, please consult TPA.

感应器连接图<原点及端点> Sensor layout

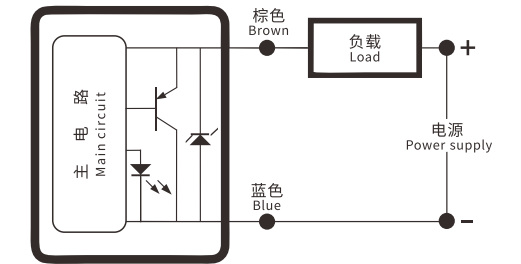

搭配伺服马达一览表 Suitable motor brand

| 伺服电机外形尺寸 servo motor size |               |               |  |                  |       |    |    |     |    |     |    |    |     |    |      |      |        |    |   |
|---------------------------|---------------|---------------|--|------------------|-------|----|----|-----|----|-----|----|----|-----|----|------|------|--------|----|---|
| 功率 Power (w)              | 品牌 Brand      | 型号 Model      | LL   | LL(刹车) LL(Brake) | LA    | LE | LZ | LC  | LG | LW  | RH | W  | LR  | S  | LB   | M    | QK     | QL |   |
| 400W                      | 三菱 Mitsubishi | HC-KFS43□K    | B: 带刹车 □: 无刹车<br>B: With brake □: No brake | 124.5            | 165.5 | 70 | 3  | 5.8 | 62 | 7   | -  | -  | -   | 30 | 14h6 | 50h7 | -      | -  | - |
|                           | 松下 Panasonic  | MSMJ042G1□    | V: 带刹车 U: 无刹车<br>V: With brake U: No brake | 99               | 135   | 70 | 3  | 4.5 | 60 | 6.5 | 20 | 11 | 5h9 | 30 | 14h6 | 50h7 | M5x10L | -  | - |
|                           | 台达 Delta      | ECMA-C20604□S | S: 带刹车 R: 无刹车<br>S: With brake R: No brake | 130.7            | 166.6 | 70 | 3  | 5.5 | 60 | 7.5 | 20 | 11 | 5   | 30 | 14h6 | 70h7 | M4x15L | -  | - |
|                           |               | ECMA-C20804□S | S: 带刹车 R: 无刹车<br>S: With brake R: No brake | 112.3            | 152.8 | 90 | 3  | 6.6 | 80 | 8   | 20 | 11 | 5   | 35 | 14h6 | 50h7 | M4x15L | -  | - |

前端连接方式 Front end connection mode

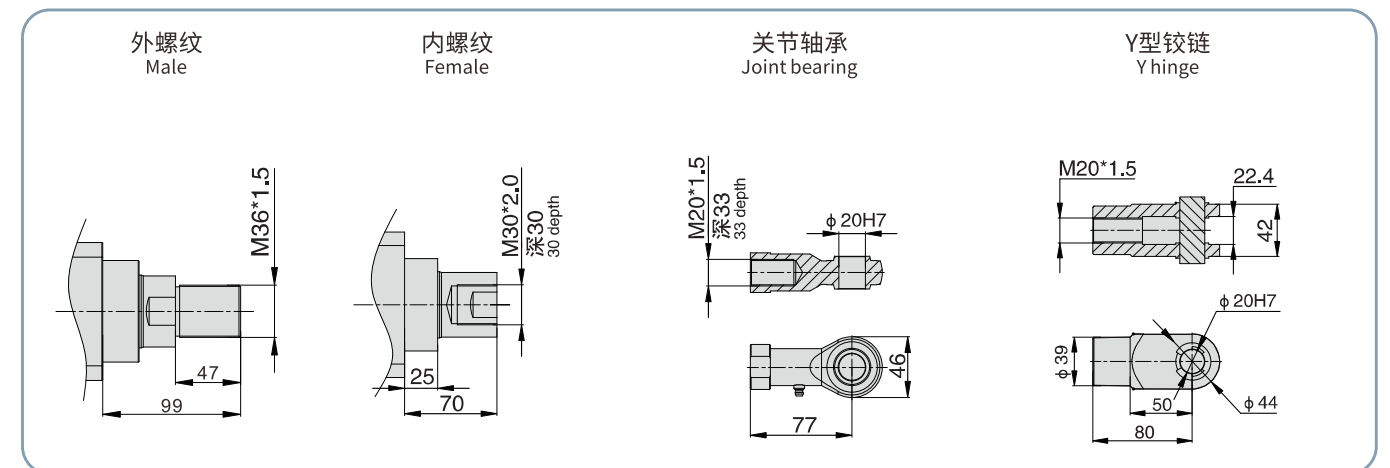



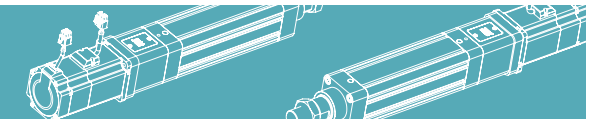

电机外置直连/电机外置右侧  
Motor external direct connection/Motor external right side

M 电机外置直连 Motor external direct connection

单位:Unit: mm

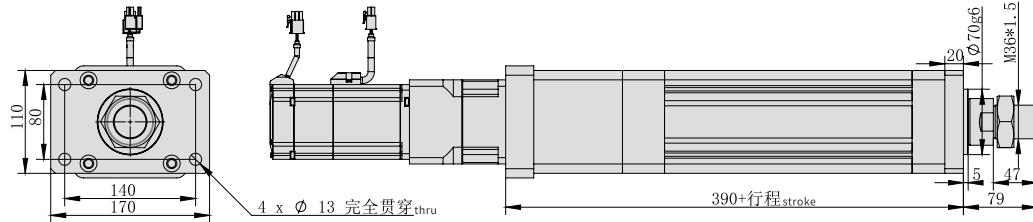

| FA 前法兰<br>Front flange | 有效行程<br>Valid stroke | 100   | 200   | 300   | 400   | 500   | 600   | 700   | 800   | 900   | 1000  | 1100  | 1200  | 1300  | 1400  | 1500  | 1600  | 1700  | 1800  | 1900  | 2000  |
|------------------------|----------------------|-------|-------|-------|-------|-------|-------|-------|-------|-------|-------|-------|-------|-------|-------|-------|-------|-------|-------|-------|-------|
| KG                     |                      | 18.40 | 20.40 | 22.40 | 24.40 | 26.40 | 28.40 | 30.40 | 32.40 | 34.40 | 36.40 | 38.40 | 40.40 | 42.40 | 44.40 | 46.40 | 48.40 | 50.40 | 52.40 | 54.40 | 56.40 |

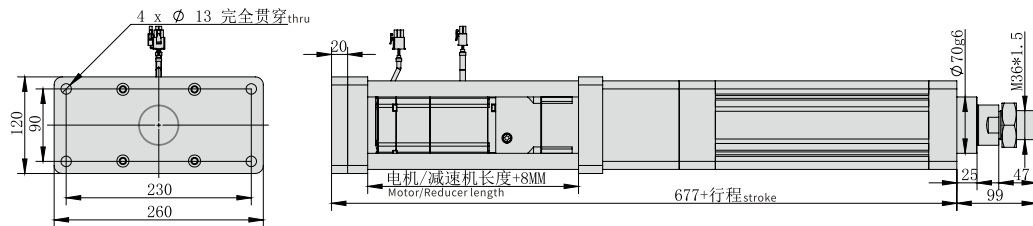

| FB 后法兰<br>Rear flange | 有效行程<br>Valid stroke | 100   | 200   | 300   | 400   | 500   | 600   | 700   | 800   | 900   | 1000  | 1100  | 1200  | 1300  | 1400  | 1500  | 1600  | 1700  | 1800  | 1900  | 2000  |
|-----------------------|----------------------|-------|-------|-------|-------|-------|-------|-------|-------|-------|-------|-------|-------|-------|-------|-------|-------|-------|-------|-------|-------|
| KG                    |                      | 21.65 | 23.65 | 25.65 | 27.65 | 29.65 | 31.65 | 33.65 | 35.65 | 37.65 | 39.65 | 41.65 | 43.65 | 45.65 | 47.65 | 49.65 | 51.65 | 53.65 | 55.65 | 57.65 | 59.65 |

备注:每增加10行程,重量增加0.03kg。 Note: for each additional 10 strokes, the weight will increase by 0.03kg.

M 电机外置直连 Motor external direct connection

单位:Unit: mm

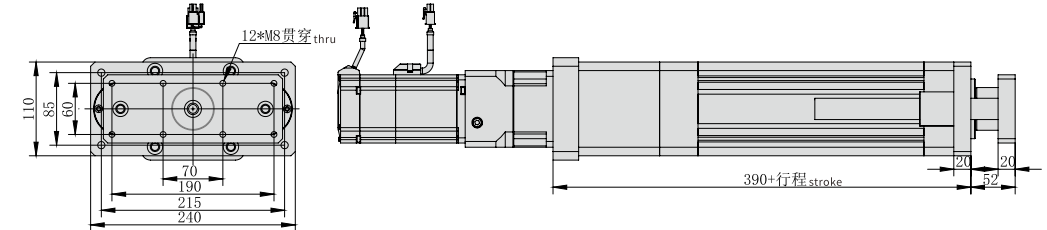

| QDX 前导向<br>Front guidance | 有效行程<br>Valid stroke | 100   | 200   | 300   | 400   | 500   | 600   | 700   | 800   | 900   | 1000  | 1100  | 1200  | 1300  | 1400  | 1500  | 1600  | 1700  | 1800  | 1900  | 2000  |
|---------------------------|----------------------|-------|-------|-------|-------|-------|-------|-------|-------|-------|-------|-------|-------|-------|-------|-------|-------|-------|-------|-------|-------|
| KG                        |                      | 18.96 | 20.96 | 22.96 | 24.96 | 26.96 | 28.96 | 30.96 | 32.96 | 34.96 | 36.96 | 38.96 | 40.96 | 42.96 | 44.96 | 46.96 | 48.96 | 50.96 | 52.96 | 54.96 | 56.96 |

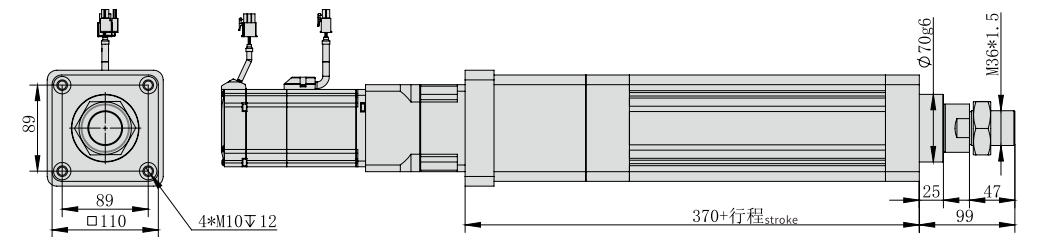

| 前端盖<br>Front end cover | 有效行程<br>Valid stroke | 100   | 200   | 300   | 400   | 500   | 600   | 700   | 800   | 900   | 1000  | 1100  | 1200  | 1300  | 1400  | 1500  | 1600  | 1700  | 1800  | 1900  | 2000  |
|------------------------|----------------------|-------|-------|-------|-------|-------|-------|-------|-------|-------|-------|-------|-------|-------|-------|-------|-------|-------|-------|-------|-------|
| KG                     |                      | 18.34 | 20.34 | 22.34 | 24.34 | 26.34 | 28.34 | 30.34 | 32.34 | 34.34 | 36.34 | 38.34 | 40.34 | 42.34 | 44.34 | 46.34 | 48.34 | 50.34 | 52.34 | 54.34 | 56.34 |

备注:每增加10行程,重量增加0.03kg。 Note: for each additional 10 strokes, the weight will increase by 0.03kg.

M 电机外置直连 Motor external direct connection

单位:Unit: mm

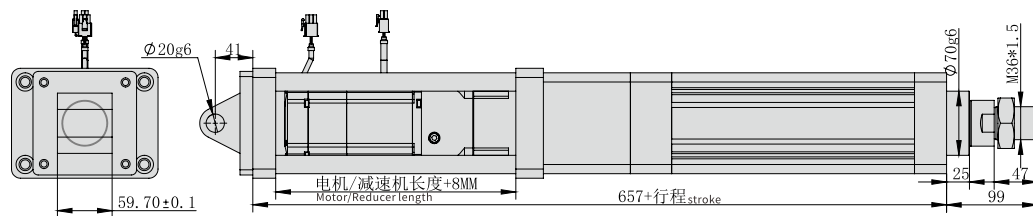

| CA 单耳尾铰<br>Single ear hinge | 有效行程<br>Valid stroke | 100   | 200   | 300   | 400   | 500   | 600   | 700   | 800   | 900   | 1000  | 1100  | 1200  | 1300  | 1400  | 1500  | 1600  | 1700  | 1800  | 1900  | 2000  |
|-----------------------------|----------------------|-------|-------|-------|-------|-------|-------|-------|-------|-------|-------|-------|-------|-------|-------|-------|-------|-------|-------|-------|-------|
| KG                          |                      | 21.54 | 23.54 | 25.54 | 27.54 | 29.54 | 31.54 | 33.54 | 35.54 | 37.54 | 39.54 | 41.54 | 43.54 | 45.54 | 47.54 | 49.54 | 51.54 | 53.54 | 55.54 | 57.54 | 59.54 |

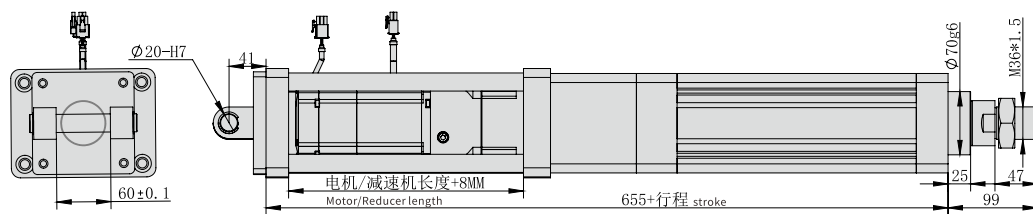

| CB 双耳尾铰<br>Ears end hinged | 有效行程<br>Valid stroke | 100   | 200   | 300   | 400   | 500   | 600   | 700   | 800   | 900   | 1000  | 1100  | 1200  | 1300  | 1400  | 1500  | 1600  | 1700  | 1800  | 1900  | 2000  |
|----------------------------|----------------------|-------|-------|-------|-------|-------|-------|-------|-------|-------|-------|-------|-------|-------|-------|-------|-------|-------|-------|-------|-------|
| KG                         |                      | 21.50 | 23.50 | 25.50 | 27.50 | 29.50 | 31.50 | 33.50 | 35.50 | 37.50 | 39.50 | 41.50 | 43.50 | 45.50 | 47.50 | 49.50 | 51.50 | 53.50 | 55.50 | 57.50 | 59.50 |

备注:每增加10行程,重量增加0.03kg。 Note: for each additional 10 strokes, the weight will increase by 0.03kg.

M 电机外置直连 Motor external direct connection

单位:Unit: mm

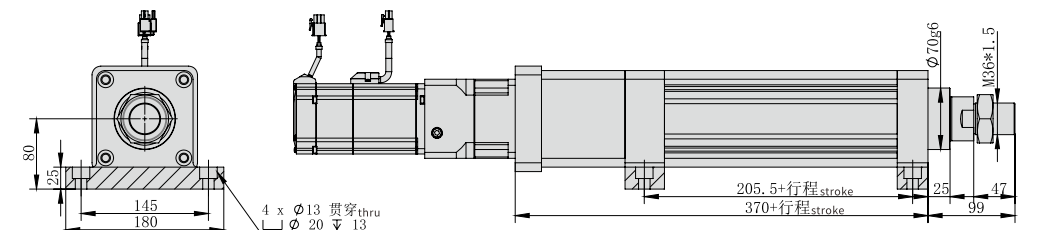

| LB 侧面安装<br>Single ear hinge | 有效行程<br>Valid stroke | 100   | 200   | 300   | 400   | 500   | 600   | 700   | 800   | 900   | 1000  | 1100  | 1200  | 1300  | 1400  | 1500  | 1600  | 1700  | 1800  | 1900  | 2000  |
|-----------------------------|----------------------|-------|-------|-------|-------|-------|-------|-------|-------|-------|-------|-------|-------|-------|-------|-------|-------|-------|-------|-------|-------|
| KG                          |                      | 18.50 | 20.50 | 22.50 | 24.50 | 26.50 | 28.50 | 30.50 | 32.50 | 34.50 | 36.50 | 38.50 | 40.50 | 42.50 | 44.50 | 46.50 | 48.50 | 50.50 | 52.50 | 54.50 | 56.50 |

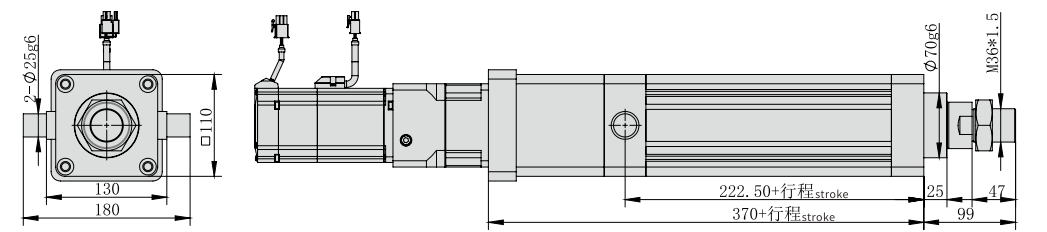

| TC 耳轴<br>Trunnion | 有效行程<br>Valid stroke | 100   | 200   | 300   | 400   | 500   | 600   | 700   | 800   | 900   | 1000  | 1100  | 1200  | 1300  | 1400  | 1500  | 1600  | 1700  | 1800  | 1900  | 2000  |
|-------------------|----------------------|-------|-------|-------|-------|-------|-------|-------|-------|-------|-------|-------|-------|-------|-------|-------|-------|-------|-------|-------|-------|
| KG                |                      | 18.36 | 20.36 | 22.36 | 24.36 | 26.36 | 28.36 | 30.36 | 32.36 | 34.36 | 36.36 | 38.36 | 40.36 | 42.36 | 44.36 | 46.36 | 48.36 | 50.36 | 52.36 | 54.36 | 56.36 |

备注:每增加10行程,重量增加0.03kg。 Note: for each additional 10 strokes, the weight will increase by 0.03kg.

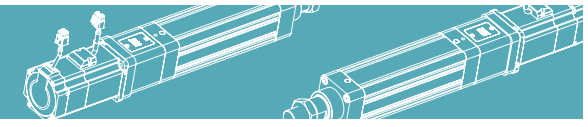

电机外置直连/电机外置右侧  
Motor external direct connection/Motor external right side

MR 电机外置右侧 Motor external right side

单位:Unit: mm

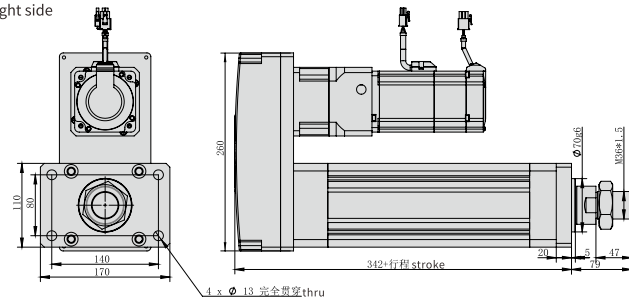

| FA 前法兰<br>Front flange | 有效行程<br>Valid stroke | 100 | 200   | 300   | 400   | 500   | 600   | 700   | 800   | 900   | 1000  | 1100  | 1200  | 1300  | 1400  | 1500  | 1600  | 1700  | 1800  | 1900  | 2000  |
|------------------------|----------------------|-----|-------|-------|-------|-------|-------|-------|-------|-------|-------|-------|-------|-------|-------|-------|-------|-------|-------|-------|-------|
|                        |                      | KG  | 16.60 | 18.60 | 20.60 | 22.60 | 24.60 | 26.60 | 28.60 | 30.60 | 32.60 | 34.60 | 36.60 | 38.60 | 40.60 | 42.60 | 44.60 | 46.60 | 48.60 | 50.60 | 52.60 |

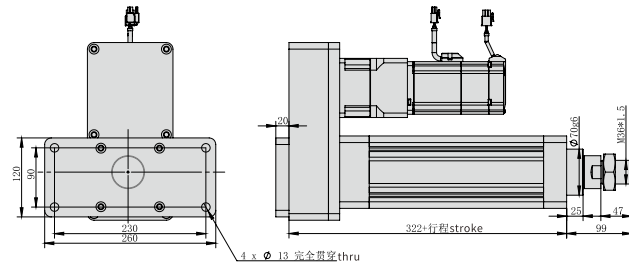

| FB 后法兰<br>Rear flange | 有效行程<br>Valid stroke | 100 | 200   | 300   | 400   | 500   | 600   | 700   | 800   | 900   | 1000  | 1100  | 1200  | 1300  | 1400  | 1500  | 1600  | 1700  | 1800  | 1900  | 2000  |
|-----------------------|----------------------|-----|-------|-------|-------|-------|-------|-------|-------|-------|-------|-------|-------|-------|-------|-------|-------|-------|-------|-------|-------|
|                       |                      | KG  | 16.71 | 18.71 | 20.71 | 22.71 | 24.71 | 26.71 | 28.71 | 30.71 | 32.71 | 34.71 | 36.71 | 38.71 | 40.71 | 42.71 | 44.71 | 46.71 | 48.71 | 50.71 | 52.71 |

备注:每增加10行程,重量增加0.03kg。 Note: for each additional 10 strokes, the weight will increase by 0.03kg.

MR 电机外置右侧 Motor external right side

单位:Unit: mm

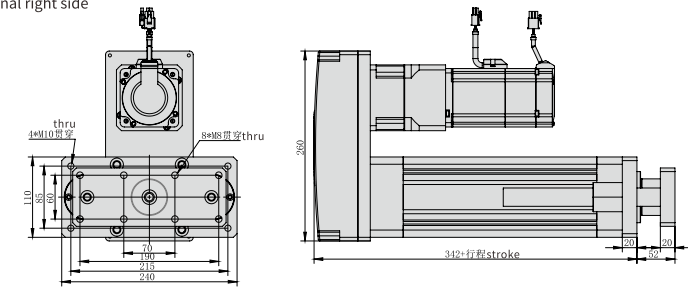

| QDX 前导向<br>Front guidance | 有效行程<br>Valid stroke | 100 | 200   | 300   | 400   | 500   | 600   | 700   | 800   | 900   | 1000  | 1100  | 1200  | 1300  | 1400  | 1500  | 1600  | 1700  | 1800  | 1900  | 2000  |
|---------------------------|----------------------|-----|-------|-------|-------|-------|-------|-------|-------|-------|-------|-------|-------|-------|-------|-------|-------|-------|-------|-------|-------|
|                           |                      | KG  | 17.16 | 19.16 | 21.16 | 23.16 | 25.16 | 27.16 | 29.16 | 31.16 | 33.16 | 35.16 | 37.16 | 39.16 | 41.16 | 43.16 | 45.16 | 47.16 | 49.16 | 51.16 | 53.16 |

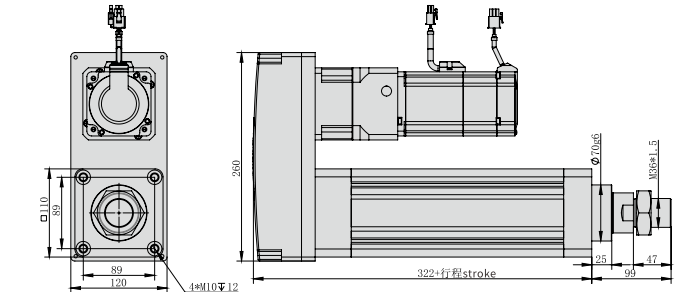

| 前端盖<br>Front end cover | 有效行程<br>Valid stroke | 100 | 200   | 300   | 400   | 500   | 600   | 700   | 800   | 900   | 1000  | 1100  | 1200  | 1300  | 1400  | 1500  | 1600  | 1700  | 1800  | 1900  | 2000  |
|------------------------|----------------------|-----|-------|-------|-------|-------|-------|-------|-------|-------|-------|-------|-------|-------|-------|-------|-------|-------|-------|-------|-------|
|                        |                      | KG  | 16.54 | 18.54 | 20.54 | 22.54 | 24.54 | 26.54 | 28.54 | 30.54 | 32.54 | 34.54 | 36.54 | 38.54 | 40.54 | 42.54 | 44.54 | 46.54 | 48.54 | 50.54 | 52.54 |

备注:每增加10行程,重量增加0.03kg。 Note: for each additional 10 strokes, the weight will increase by 0.03kg.

MR 电机外置右侧 Motor external right side

单位:Unit: mm

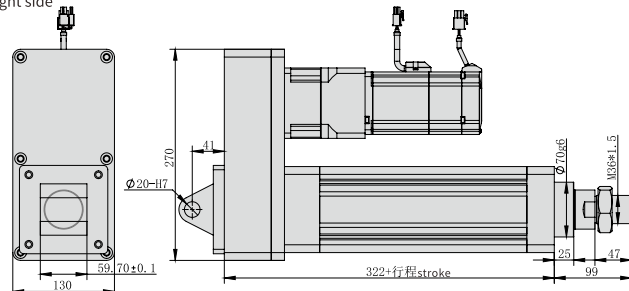

| CA 单耳尾铰<br>Single ear hinge | 有效行程<br>Valid stroke | 100 | 200   | 300   | 400   | 500   | 600   | 700   | 800   | 900   | 1000  | 1100  | 1200  | 1300  | 1400  | 1500  | 1600  | 1700  | 1800  | 1900  | 2000  |
|-----------------------------|----------------------|-----|-------|-------|-------|-------|-------|-------|-------|-------|-------|-------|-------|-------|-------|-------|-------|-------|-------|-------|-------|
|                             |                      | KG  | 16.68 | 18.68 | 20.68 | 22.68 | 24.68 | 26.68 | 28.68 | 30.68 | 32.68 | 34.68 | 36.68 | 38.68 | 40.68 | 42.68 | 44.68 | 46.68 | 48.68 | 50.68 | 52.68 |

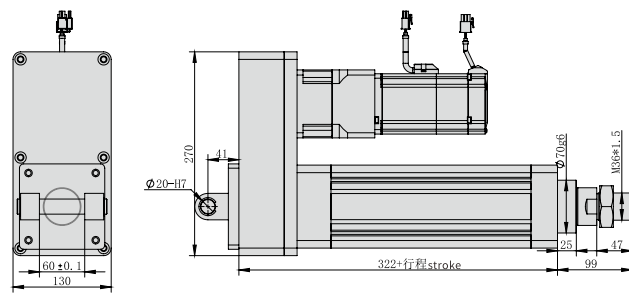

| CB 双耳尾铰<br>Ears end hinged | 有效行程<br>Valid stroke | 100 | 200   | 300   | 400   | 500   | 600   | 700   | 800   | 900   | 1000  | 1100  | 1200  | 1300  | 1400  | 1500  | 1600  | 1700  | 1800  | 1900  | 2000  |
|----------------------------|----------------------|-----|-------|-------|-------|-------|-------|-------|-------|-------|-------|-------|-------|-------|-------|-------|-------|-------|-------|-------|-------|
|                            |                      | KG  | 16.66 | 18.66 | 20.66 | 22.66 | 24.66 | 26.66 | 28.66 | 30.66 | 32.66 | 34.66 | 36.66 | 38.66 | 40.66 | 42.66 | 44.66 | 46.66 | 48.66 | 50.66 | 52.66 |

备注:每增加10行程,重量增加0.03kg。 Note: for each additional 10 strokes, the weight will increase by 0.03kg.

MR 电机外置右侧 Motor external right side

单位:Unit: mm

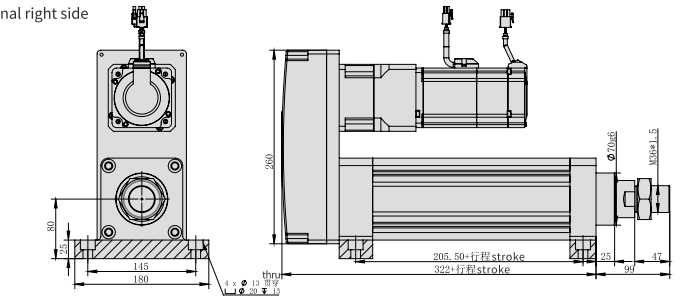

| LB 侧面安装<br>Single ear hinge | 有效行程<br>Valid stroke | 100 | 200   | 300   | 400   | 500   | 600   | 700   | 800   | 900   | 1000  | 1100  | 1200  | 1300  | 1400  | 1500  | 1600  | 1700  | 1800  | 1900  | 2000  |
|-----------------------------|----------------------|-----|-------|-------|-------|-------|-------|-------|-------|-------|-------|-------|-------|-------|-------|-------|-------|-------|-------|-------|-------|
|                             |                      | KG  | 16.70 | 18.70 | 20.70 | 22.70 | 24.70 | 26.70 | 28.70 | 30.70 | 32.70 | 34.70 | 36.70 | 38.70 | 40.70 | 42.70 | 44.70 | 46.70 | 48.70 | 50.70 | 52.70 |

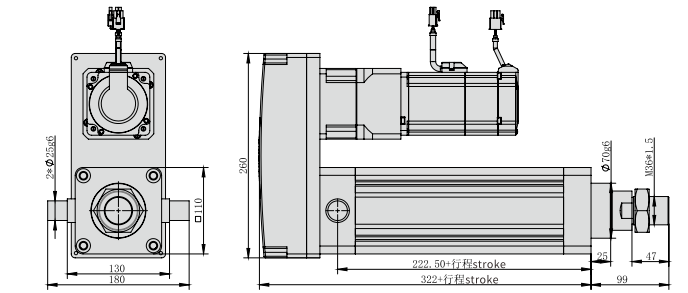

| TC 耳轴<br>Trunnion | 有效行程<br>Valid stroke | 100 | 200   | 300   | 400   | 500   | 600   | 700   | 800   | 900   | 1000  | 1100  | 1200  | 1300  | 1400  | 1500  | 1600  | 1700  | 1800  | 1900  | 2000  |
|-------------------|----------------------|-----|-------|-------|-------|-------|-------|-------|-------|-------|-------|-------|-------|-------|-------|-------|-------|-------|-------|-------|-------|
|                   |                      | KG  | 16.56 | 18.56 | 20.56 | 22.56 | 24.56 | 26.56 | 28.56 | 30.56 | 32.56 | 34.56 | 36.56 | 38.56 | 40.56 | 42.56 | 44.56 | 46.56 | 48.56 | 50.56 | 52.56 |

备注:每增加10行程,重量增加0.03kg。 Note: for each additional 10 strokes, the weight will increase by 0.03kg.

- HNR
- HCR
- HNB
- HCB
- HNT
- XYZ
- ONB
- OCB
- GCR
- GCB
- GCBS
- GCRS
- ESR**
- EMR
- EHR
- KSR
- LNP
- DDR
- 参考资料  
Reference data