



重复精度  
Repeat Accuracy  
±0.04  
mm

此图仅供参考, 出货规格详见尺寸图面  
This picture for reference only, specs details according with the drawing.

最大行程  
Max stroke 3050mm

最高速度  
Max speed 4500mm/s

马达容量  
Motor output 200W

直线滑轨  
Linear guide 15X12.5-1支

型号表达方式 Ordering method

TPA-HNB-65S-90-L3050-MR-Y-P20-N3-F

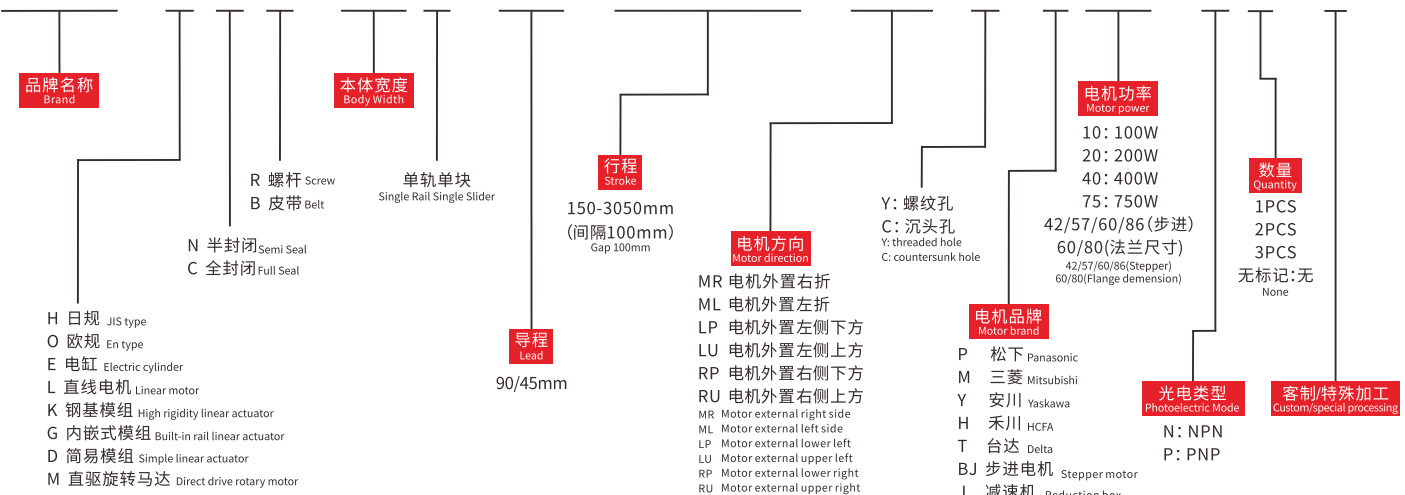

产品性能参数如下 Product performance parameters are as follows

规格 Spec	电机功率 (W) Motor power (W)	200	
	重复定位精度 (mm) Repeated positioning accuracy (mm)	±0.04	
	减速比 (mm) Reduction ratio	1:1	1:2
	导程 (mm) Lead (mm)	90	45
	最高速度 (mm/s) Maximum speed (mm/s)	4500	
	电机额定转速 (RPM) Rated speed of motor (RPM)	3000	
部 品 Parts	最大可搬重量 Maximum Payload	4	8
	标准行程 (mm) Stroke pitch (mm)	150~3050mm/100 间隔100 mm Pitch	
	基座材质 Material of base	硬质挤压铝材A1 Hard extruded aluminum A1	
使用环境 Operating environment	0~40°C, 85%RH (无凝结) No condensation		

注1: 使用非上述功率电机时请依据实际参数推算。  
Note 1: When using a motor with a power other than the above, please calculate according to the actual parameters.

注2: 最高速度因行程和负载而异, 当螺杆细长比大于1:50时, 可能会因螺杆临界速度产生共振和抖动, 应适当下调运行速度, 一般螺杆每增长100mm, 速度应下调10~15%。  
Note 2: The maximum speed varies with stroke and load. When the screw slenderness ratio is greater than 1:50, resonance and jitter may occur due to the critical speed of the screw, so the running speed should be reduced appropriately. Generally, the speed should be reduced by 10~15% for every 100mm increase of the screw.

传感器连接图<原点及端点> Sensor layout

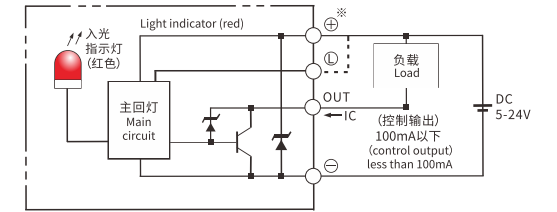

容许负载力矩表 N.m Allowable overhang

负载 Load	水平安装 Horizontal installation			侧面安装 Side mounting		
	A	B	C	A	B	C
5kg	620	65	165	582	59	151
10kg	253	29	73	532	26	66
15kg	126	16	42	111	15	38

静态容许负载惯量 Static loading moment

惯量	值 (N.m)
MY	16
MP	20
MR	19

\*力矩表所表示的数据, 代表重心。  
The torque value in the chart indicate the center of gravity.

\*符合录规范的正常试用下, 保证寿命为10000公里。  
Operation life is 10,000km when the product is using under the specified conditions.

\*侧吊使用无法套用标准规范, 如有需求请咨询我司业务。  
The standard specification cannot be applied to the use of inverted crane. Please consult our business if necessary.

搭配伺服马达一览表 Suitable motor brand

品牌 Brand	马达记号 Mark	刹车有无 Brake	马达容量 Motor capacity	电源电压 AC-Voltage	伺服马达型号 Servo motor model	驱动器型号 Driver Model
三菱 Mitsubishi	M	无刹车(水平式样) No brake (horizontal type)	200	220	HG-KR73	MR-J4-70A
松下 Panasonic	P	无刹车(水平式样) No brake (horizontal type)	200	220	MHMD082G1U	MBDHT3520
台达 Delta	T	无刹车(水平式样) No brake (horizontal type)	200	220	ECMA-C20807ES	ASD-B20721-B





电机外置右下/电机外置右上  
Motor external lower right / Motor external upper right

RP 电机外置右下 Motor external lower right

单位:Unit: mm

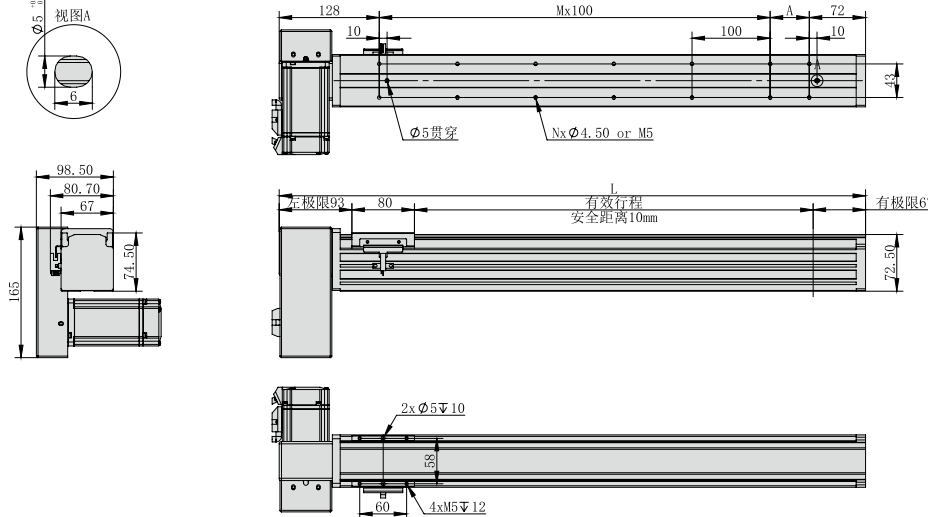

\*不含电机重量。\*Motor weight not included.

有效行程 Stroke	150	250	350	450	550	650	750	850	950	1050	1150	1250	1350	1450	1550	1650	1750	1850	1950	2050	2150	2250	2350	2450	2550	2650	2750	2850	2950	3050
L	400	500	600	700	800	900	1000	1100	1200	1300	1400	1500	1600	1700	1800	1900	2000	2100	2200	2300	2400	2500	2600	2700	2800	2900	3000	3100	3200	3300
A	100	100	100	100	100	100	100	100	100	100	100	100	100	100	100	100	100	100	100	100	100	100	100	100	100	100	100	100	100	100
N	6	8	10	12	14	16	18	20	22	24	26	28	30	32	34	36	38	40	42	44	46	48	50	52	54	56	58	60	62	64
M	1	2	3	4	5	6	7	8	9	10	11	12	13	14	15	16	17	18	19	20	21	22	23	24	25	26	27	28	29	30
KG	3	3.4	3.8	4.2	4.6	5	5.4	5.8	6.2	6.6	7	7.4	7.8	8.2	8.6	9	9.4	9.8	10.2	10.6	11	11.4	11.8	12.2	12.6	13	13.4	13.8	14.2	14.6

如有超长行程及定制需求,请咨询我司业务。If you have extra long trip and custom requirements, please consult our business.

RU 电机外置右上 Motor external upper right

单位:Unit: mm

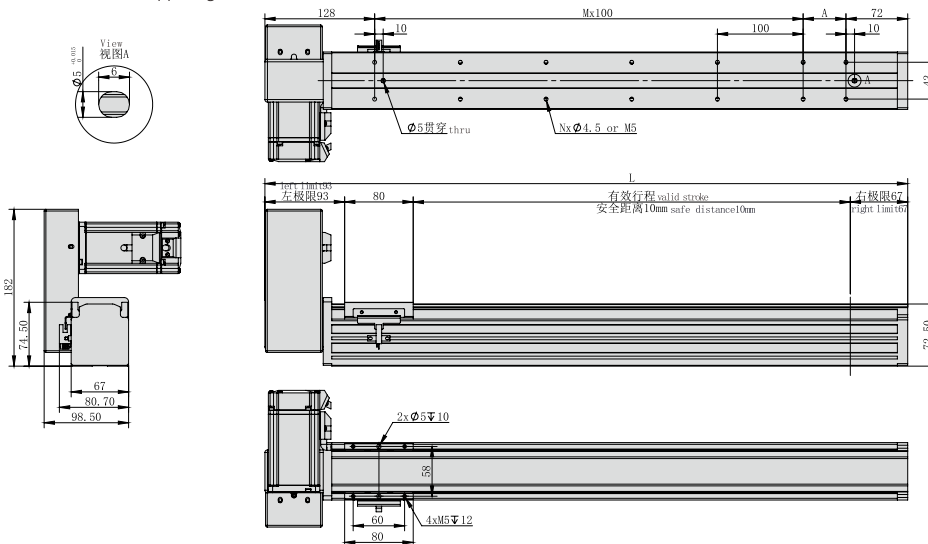

\*不含电机重量。\*Motor weight not included.

有效行程 Stroke	150	250	350	450	550	650	750	850	950	1050	1150	1250	1350	1450	1550	1650	1750	1850	1950	2050	2150	2250	2350	2450	2550	2650	2750	2850	2950	3050
L	400	500	600	700	800	900	1000	1100	1200	1300	1400	1500	1600	1700	1800	1900	2000	2100	2200	2300	2400	2500	2600	2700	2800	2900	3000	3100	3200	3300
A	100	100	100	100	100	100	100	100	100	100	100	100	100	100	100	100	100	100	100	100	100	100	100	100	100	100	100	100	100	100
N	6	8	10	12	14	16	18	20	22	24	26	28	30	32	34	36	38	40	42	44	46	48	50	52	54	56	58	60	62	64
M	1	2	3	4	5	6	7	8	9	10	11	12	13	14	15	16	17	18	19	20	21	22	23	24	25	26	27	28	29	30
KG	3	3.4	3.8	4.2	4.6	5	5.4	5.8	6.2	6.6	7	7.4	7.8	8.2	8.6	9	9.4	9.8	10.2	10.6	11	11.4	11.8	12.2	12.6	13	13.4	13.8	14.2	14.6

如有超长行程及定制需求,请咨询我司业务。If you have extra long trip and custom requirements, please consult our business.

知识小课堂 Knowledge classroom

日规模组原理 Theory of Asia Standard Linear Actuator

伺服滑台是一种将伺服马达、滚珠螺杆(或同步带、齿轮齿条)、导轨等相结合的一种小型设备,通过电机旋转运动来驱动传动结构转换成直线运动,从而实现高精度、高速度、高负载的直线运行工作。

Servo slide table is a kind of small equipment which combines servo motor, ball screw (or synchronous belt, rack and pinion) and guide rail. The transmission structure is converted into linear motion through the rotary motion of the motor, so as to realize high-precision, high-speed and high-load linear operation.

日规模组特点 Feature of Asia Standard Linear Actuator

伺服滑台作为一款小型集成设备有着许多特点,精度高、重复定位精度最高可达 $\pm 0.008\text{mm}$ ,运行速度快、可以采用螺杆、同步带及齿轮齿条等传动方式,安装方便、可在恶劣的工作环境下无故障运行;本体质量轻、占设备空间小,高刚性、寿命长、噪音低、控制简单、维护方便等。

As a small integrated equipment, the servo slide table has many characteristics, such as high precision, repeated positioning accuracy up to  $\pm 0.01\text{mm}$ , fast running speed, convenient installation and trouble-free operation in harsh working environment. Light weight, small equipment space, high rigidity, long service life, low noise, simple control and convenient maintenance.

日规模组产品优势 Product advantage of Asia Standard Linear Actuator

1、传动结构多样化 Diversification of transmission structure

作为一款小型集成设备,滑台在结构方面既简单又有着多样的选择性,目前广泛使用的可分为三类型,滚珠螺杆型、同步带型以及齿轮齿条形式,可适用于不同的工作环境。

As a small integrated equipment, the sliding table is simple in structure and has a variety of options. At present, it can be widely used in three types: ball screw type, synchronous belt type and rack and pinion type, which can be applied to different working environments.

2、控制简单、适用性强 Simple control and strong applicability

由伺服、步进等电机驱动,既有着伺服电机的高精度、也有滑台本身高速度、高刚性的优势,操控简单可轻易与PLC等系统连接。

Driven by servo, stepper and other motors, it not only has the high precision of servo motor, but also has the advantages of high speed and high rigidity of sliding table itself. It is easy to control and can be easily connected with PLC and other systems.

3、安装便捷、尺寸可非标化 Convenient installation and nonstandard size

滑台采用的是一体挤压成型铝型材,本体质量轻、尺寸小、刚性强、安装尺寸、行程都可以按要求非标定制,安装使用螺栓固定便可。

The sliding table is made of integrally extruded aluminum profile, with light weight, small size and strong rigidity. The installation size and stroke can be customized according to the requirements, and the installation can be fixed by bolts.

4、组合搭建 Combined construction

滑台可通过多放向的组合,组成设备上的运动执行机构,例如工业机械手XYZ轴机械手、坐标轴滑台等。

The sliding table can be combined with multiple directions to form the motion executing mechanism on the equipment, such as XYZ axis manipulator, coordinate axis sliding table and so on.

HNR

HCR

HNB

HCB

HNT

XYZ

ONB

OCB

GCR

GCB

GCBS

GCRS

ESR

EMR

EHR

KSR

LNP

DDR

参考资料  
Reference data



重复精度  
Repeat Accuracy  
±0.04  
mm

此图仅供参考, 出货规格详见尺寸图面  
This picture for reference only, specs details according with the drawing.

最大行程  
Max stroke 3050mm

最高速度  
Max speed 4500mm/s

马达容量  
Motor output 200W

直线滑轨  
Linear guide 15X12.5-1支

型号表达方式 Ordering method

TPA-HNB-85S-90-L3050-MR-Y-P20-N3-F

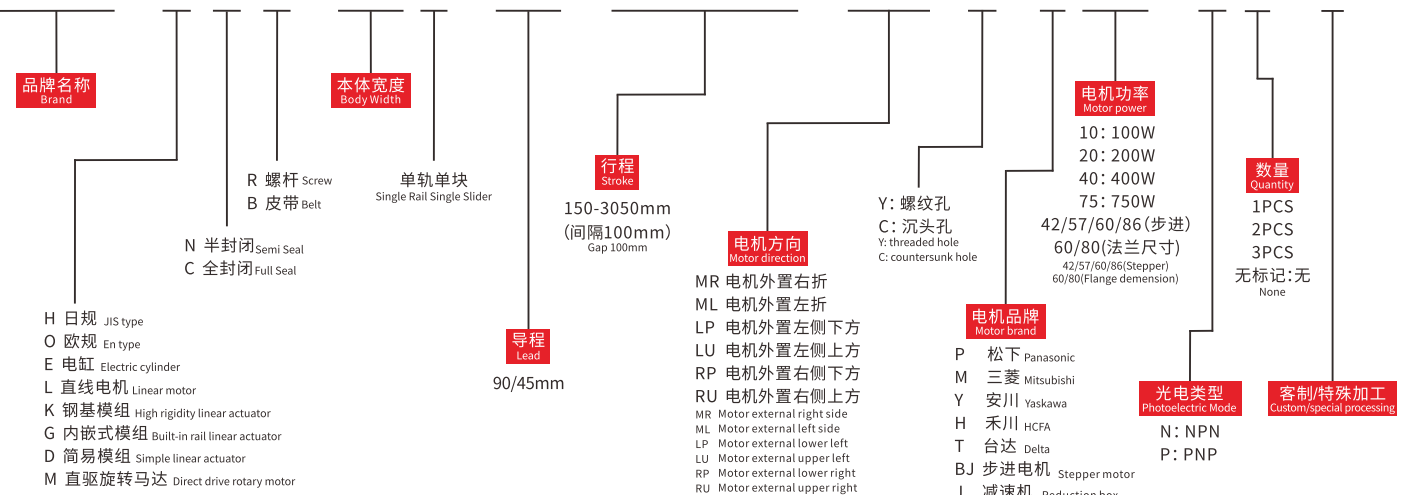

产品性能参数如下 Product performance parameters are as follows

规格 Spec	电机功率 (W) Motor power (W)	200	
	重复定位精度 (mm) Repeated positioning accuracy (mm)	±0.04	
	减速比 (mm) Reduction ratio	1:1	1:2
	导程 (mm) Lead (mm)	90	45
	最高速度 (mm/s) Maximum speed (mm/s)	4500	
	电机额定转速 (RPM) Rated speed of motor (RPM)	3000	
部 品 Parts	最大可搬重量 Maximum Payload	7	14
	标准行程 (mm) Stroke pitch (mm)	150~3050mm/100 间隔100 mm Pitch	
	基座材质 Material of base	硬质挤压铝材A1 Hard extruded aluminum A1	
使用环境 Operating environment	0~40°C, 85%RH(无凝结) No condensation		

注1: 使用非上述功率电机时请依据实际参数推算。  
Note 1: When using a motor with a power other than the above, please calculate according to the actual parameters.

注2: 最高速度因行程和负载而异, 当螺杆细长比大于1:50时, 可能会因螺杆临界速度产生共振和抖动, 应适当下调运行速度, 一般螺杆每增长100mm, 速度应下调10~15%。  
Note 2: The maximum speed varies with stroke and load. When the screw slenderness ratio is greater than 1:50, resonance and jitter may occur due to the critical speed of the screw, so the running speed should be reduced appropriately. Generally, the speed should be reduced by 10~15% for every 100mm increase of the screw.

传感器连接图<原点及端点> Sensor layout

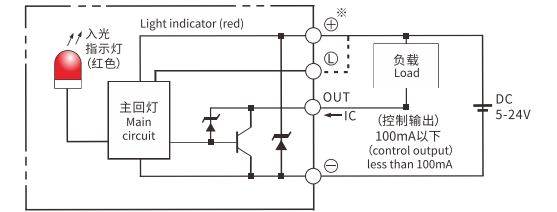

容许负载力矩表 N.m Allowable overhang

(单位Unit:mm)				(单位Unit:mm)					
水平安装 Horizontal installation	A	B	C	侧面安装 Side mounting	A	B	C		
负载 Load	5kg	630	410	271	负载 Load	5kg	255	290	383
	13kg	300	188	61		13kg	88	95	144
	20kg	195	102	-		20kg	-	-	-

静态容许负载惯量 Static loading moment

(单位Unit:N.m)	
MY	80
MP	80
MR	90

\*力矩表所表示的数据, 代表重心。  
The torque value in the chart indicate the center of gravity.

\*符合录规范的正常试用下, 保证寿命为10000公里。  
Operation life is 10,000km when the product is using under the specified conditions.

\*侧吊使用无法套用标准规范, 如有需求请咨询我司业务。  
The standard specification cannot be applied to the use of inverted crane. Please consult our business if necessary.

搭配伺服马达一览表 Suitable motor brand

品牌 Brand	马达记号 Mark	刹车有无 Brake	马达容量 Motor capacity	电源电压 AC-Voltage	伺服马达型号 Servo motor model	驱动器型号 Driver Model
三菱 Mitsubishi	M	无刹车(水平式样) No brake (horizontal type)	200	220	HG-KR73	MR-J4-70A
松下 Panasonic	P	无刹车(水平式样) No brake (horizontal type)	200	220	MHMD082G1U	MBDHT3520
台达 Delta	T	无刹车(水平式样) No brake (horizontal type)	200	220	ECMA-C20807ES	ASD-B20721-B





电机外置右下/电机外置右上  
Motor external lower right / Motor external upper right

RP 电机外置右下 Motor external lower right

单位:Unit: mm

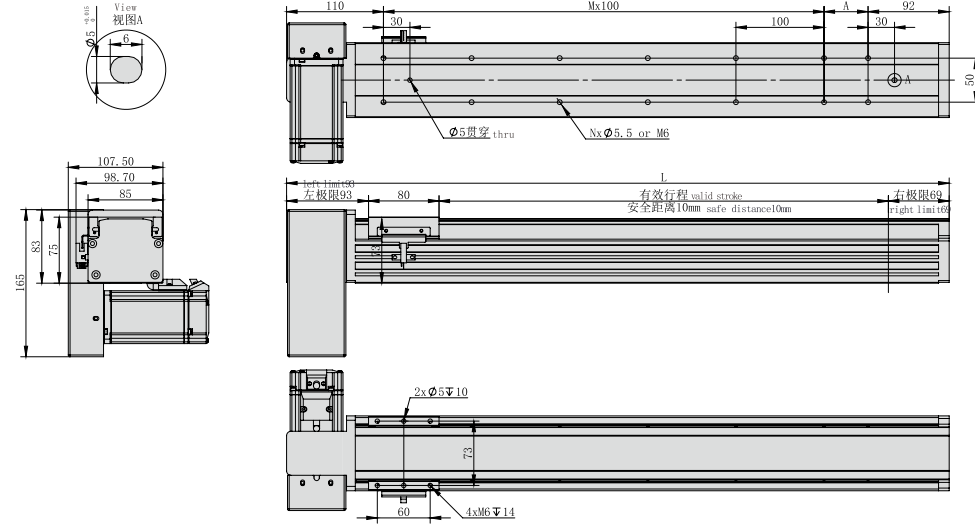

\*不含电机重量。\*Motor weight not included.

有效行程 Stroke	150	250	350	450	550	650	750	850	950	1050	1150	1250	1350	1450	1550	1650	1750	1850	1950	2050	2150	2250	2350	2450	2550	2650	2750	2850	2950	3050
L	402	502	602	702	802	902	1002	1102	1202	1302	1402	1502	1602	1702	1802	1902	2002	2102	2202	2302	2402	2502	2602	2702	2802	2902	3002	3102	3202	3302
A	100	100	100	100	100	100	100	100	100	100	100	100	100	100	100	100	100	100	100	100	100	100	100	100	100	100	100	100	100	100
N	6	8	10	12	14	16	18	20	22	24	26	28	30	32	34	36	38	40	42	44	46	48	50	52	54	56	58	60	62	64
M	1	2	3	4	5	6	7	8	9	10	11	12	13	14	15	16	17	18	19	20	21	22	23	24	25	26	27	28	29	30
KG	3.2	3.6	4	4.4	4.8	5.2	5.6	6	6.4	6.8	7.2	7.6	8	8.4	8.8	9.2	9.6	10	10.4	10.8	11.2	11.6	12	12.4	12.8	13.2	13.6	14	14.4	14.8

如有超长行程及定制需求,请咨询我司业务。If you have extra long trip and custom requirements, please consult our business.

RU 电机外置右上 Motor external upper right

单位:Unit: mm

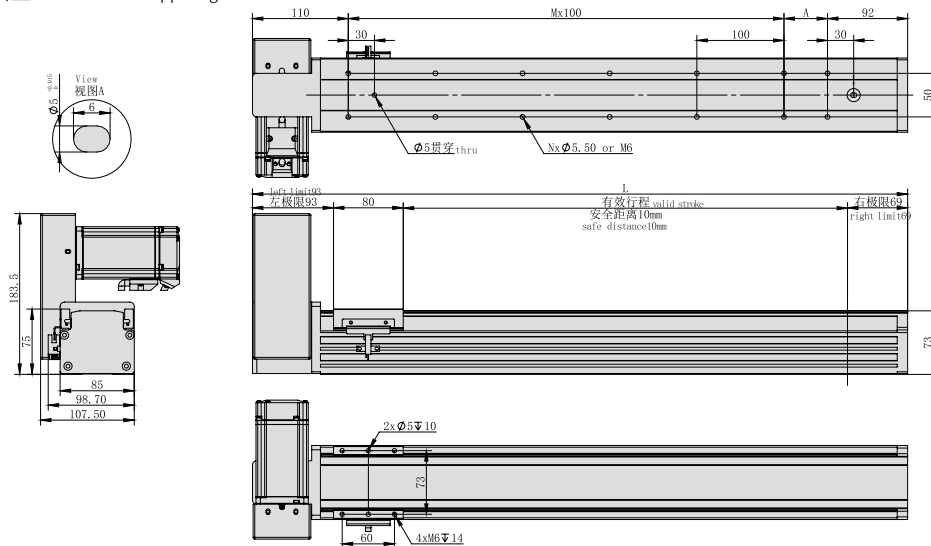

\*不含电机重量。\*Motor weight not included.

有效行程 Stroke	150	250	350	450	550	650	750	850	950	1050	1150	1250	1350	1450	1550	1650	1750	1850	1950	2050	2150	2250	2350	2450	2550	2650	2750	2850	2950	3050
L	402	502	602	702	802	902	1002	1102	1202	1302	1402	1502	1602	1702	1802	1902	2002	2102	2202	2302	2402	2502	2602	2702	2802	2902	3002	3102	3202	3302
A	100	100	100	100	100	100	100	100	100	100	100	100	100	100	100	100	100	100	100	100	100	100	100	100	100	100	100	100	100	100
N	6	8	10	12	14	16	18	20	22	24	26	28	30	32	34	36	38	40	42	44	46	48	50	52	54	56	58	60	62	64
M	1	2	3	4	5	6	7	8	9	10	11	12	13	14	15	16	17	18	19	20	21	22	23	24	25	26	27	28	29	30
KG	3.2	3.6	4	4.4	4.8	5.2	5.6	6	6.4	6.8	7.2	7.6	8	8.4	8.8	9.2	9.6	10	10.4	10.8	11.2	11.6	12	12.4	12.8	13.2	13.6	14	14.4	14.8

如有超长行程及定制需求,请咨询我司业务。If you have extra long trip and custom requirements, please consult our business.

MEMO

HNR

HCR

HNB

HCB

HNT

XYZ

ONB

OCB

GCR

GCB

GCBS

GCRS

ESR

EMR

EHR

KSR

LNP

DDR

参考资料  
Reference data



重复精度  
Repeat Accuracy  
±0.04  
mm

此图仅供参考, 出货规格详见尺寸图面  
This picture for reference only, specs details according with the drawing.

最大行程  
Max stroke 1050mm

最高速度  
Max speed 4500mm/s

马达容量  
Motor output 200W

直线滑轨  
Linear guide 9X6.5-2支

型号表达方式 Ordering method

**TPA-HNB-85D-90-L1050-MR-Y-P20-N3-F**

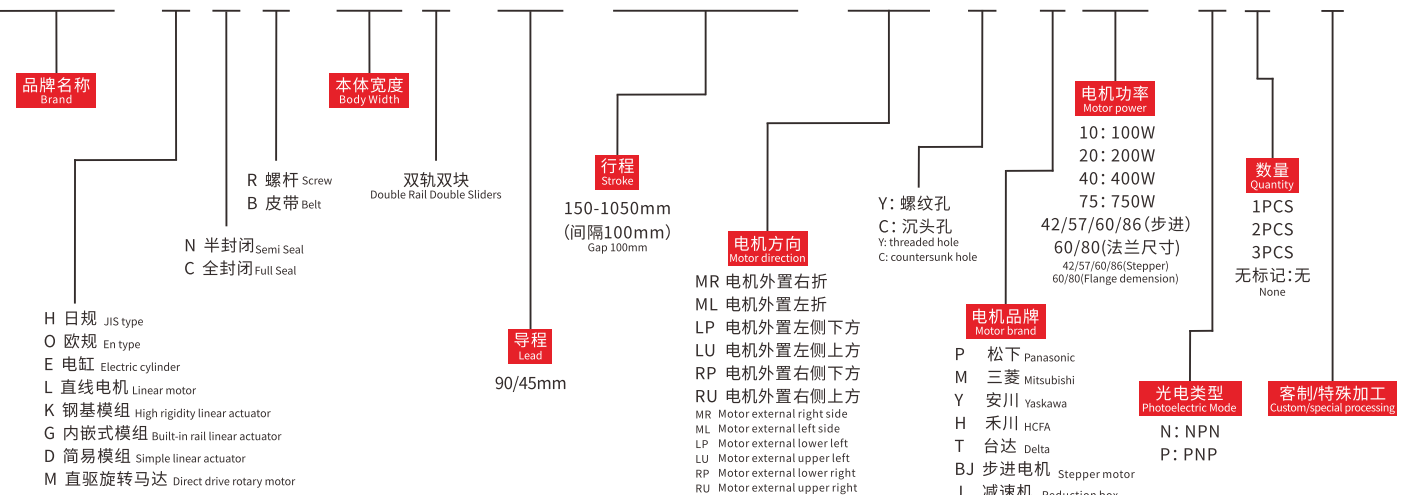

产品性能参数如下 Product performance parameters are as follows

电机功率 (W) Motor power (W)	200	
重复定位精度 (mm) Repeated positioning accuracy (mm)	±0.04	
减速比 (mm) Reduction ratio	1:1	1:2
规格 导程 (mm) Lead (mm)	90	45
最高速度 (mm/s) Maximum speed (mm/s)	4500	
电机额定转速 (RPM) Rated speed of motor (RPM)	3000	
最大可搬重量 Maximum Payload	7	14
标准行程 (mm) Stroke pitch (mm)	150~1050mm/100 间隔100 mm Pitch	
部 品 材 质 Material of base	硬质挤压铝材A1 Hard extruded aluminum A1	
使用环境 Operating environment	0~40°C, 85%RH (无凝结) No condensation	

注1: 使用非上述功率电机时请依据实际参数推算。  
Note 1: When using a motor with a power other than the above, please calculate according to the actual parameters.  
注2: 最高速度因行程和负载而异, 当螺杆细长比大于1:50时, 可能会因螺杆临界速度产生共振和抖动, 应适当下调运行速度, 一般螺杆每增长100mm, 速度应下调10~15%。  
Note 2: The maximum speed varies with stroke and load. When the screw slenderness ratio is greater than 1:50, resonance and jitter may occur due to the critical speed of the screw, so the running speed should be reduced appropriately. Generally, the speed should be reduced by 10~15% for every 100mm increase of the screw.

传感器连接图<原点及端点> Sensor layout

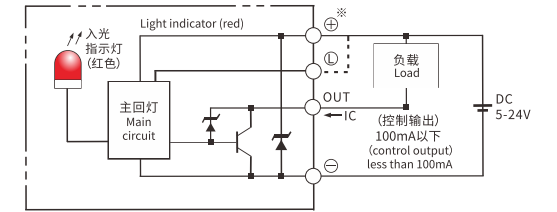

容许负载力矩表 N.m Allowable overhang

负载 Load	水平安装 Horizontal installation			侧面安装 Side mounting		
	A	B	C	A	B	C
5kg	630	410	271	5kg	255	290
13kg	300	188	61	13kg	88	95
20kg	195	102	-	20kg	-	-

静态容许负载惯量 Static loading moment

惯量 Inertia	容许值 Allowable value (Unit: N.m)
MY	80
MP	80
MR	90

\*力矩表所表示的数据, 代表重心。  
The torque value in the chart indicate the center of gravity.  
\*符合型录规范的正常试用下, 保证寿命为10000公里。  
Operation life is 10,000km when the product is using under the specified conditions.  
\*侧吊使用无法套用标准规范, 如有需求请咨询我司业务。  
The standard specification cannot be applied to the use of inverted crane. Please consult our business if necessary.

搭配伺服马达一览表 Suitable motor brand

品牌 Brand	马达记号 Mark	刹车有无 Brake	马达容量 Motor capacity	电源电压 AC-Voltage	伺服马达型号 Servo motor model	驱动器型号 Driver Model
三菱 Mitsubishi	M	无刹车(水平式样) No brake (horizontal type)	200	220	HG-KR73	MR-J4-70A
松下 Panasonic	P	无刹车(水平式样) No brake (horizontal type)	200	220	MHMD082G1U	MBDHT3520
台达 Delta	T	无刹车(水平式样) No brake (horizontal type)	200	220	ECMA-C20807ES	ASD-B20721-B



电机外置左侧/电机外置右侧  
Motor external left side / Motor external right side

ML 电机外置左侧 Motor external left side

单位:Unit: mm

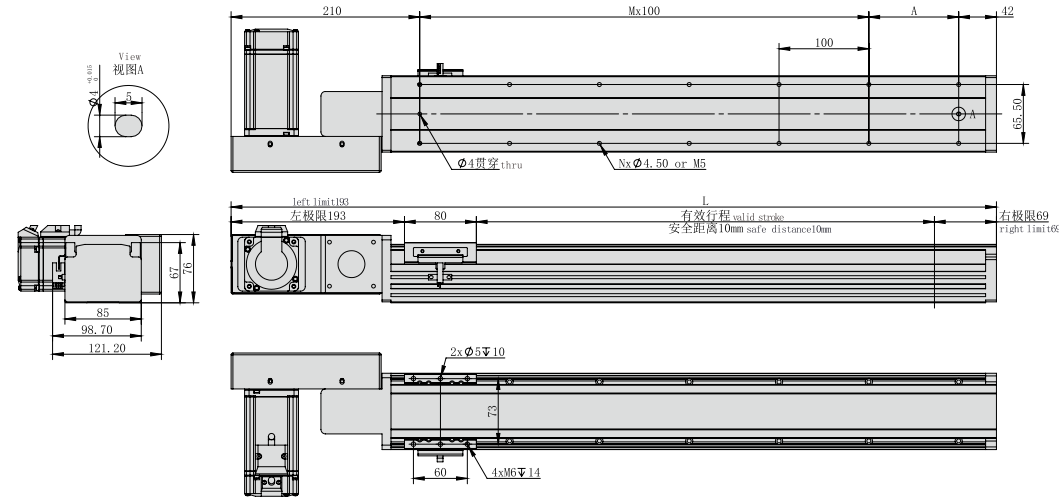

\*不含电机重量。\*Motor weight not included.

有效行程 Stroke	150	250	350	450	550	650	750	850	950	1050
L	501	601	701	801	901	1001	1101	1201	1301	1401
A	50	50	50	50	50	50	50	50	50	50
N	8	10	12	14	16	18	20	22	24	26
M	2	3	4	5	6	7	8	9	10	11
KG	3.2	3.6	4	4.4	4.8	5.2	5.6	6	6.4	6.8

如有超长行程及定制需求,请咨询我司业务。If you have extra long trip and custom requirements, please consult our business.

电机外置左下/电机外置左上  
Motor external lower left / Motor external upper left

LP 电机外置左下 Motor external lower left

单位:Unit: mm

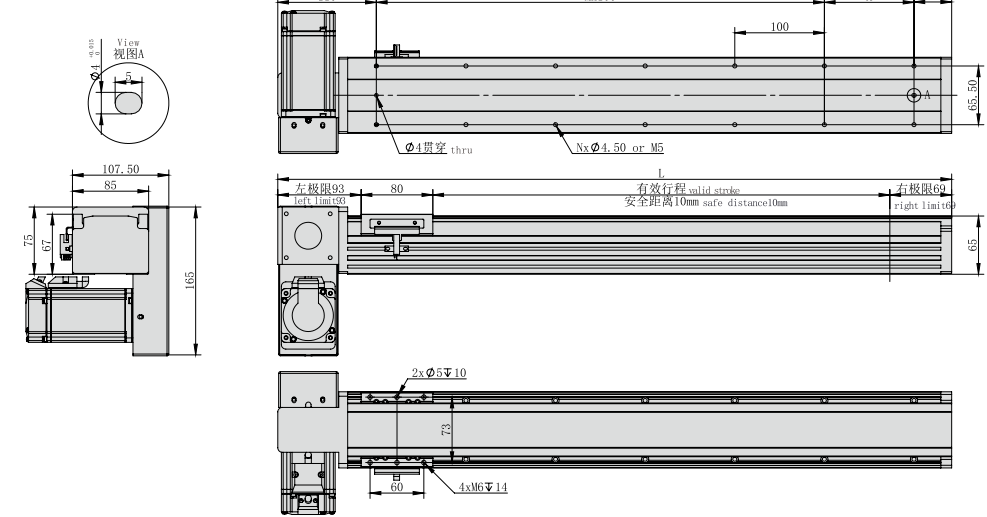

\*不含电机重量。\*Motor weight not included.

有效行程 Stroke	150	250	350	450	550	650	750	850	950	1050
L	402	502	602	702	802	902	1002	1102	1202	1302
A	50	50	50	50	50	50	50	50	50	50
N	8	10	12	14	16	18	20	22	24	26
M	2	3	4	5	6	7	8	9	10	11
KG	3.2	3.6	4	4.4	4.8	5.2	5.6	6	6.4	6.8

如有超长行程及定制需求,请咨询我司业务。If you have extra long trip and custom requirements, please consult our business.

MR 电机外置右侧 Motor external right side

单位:Unit: mm

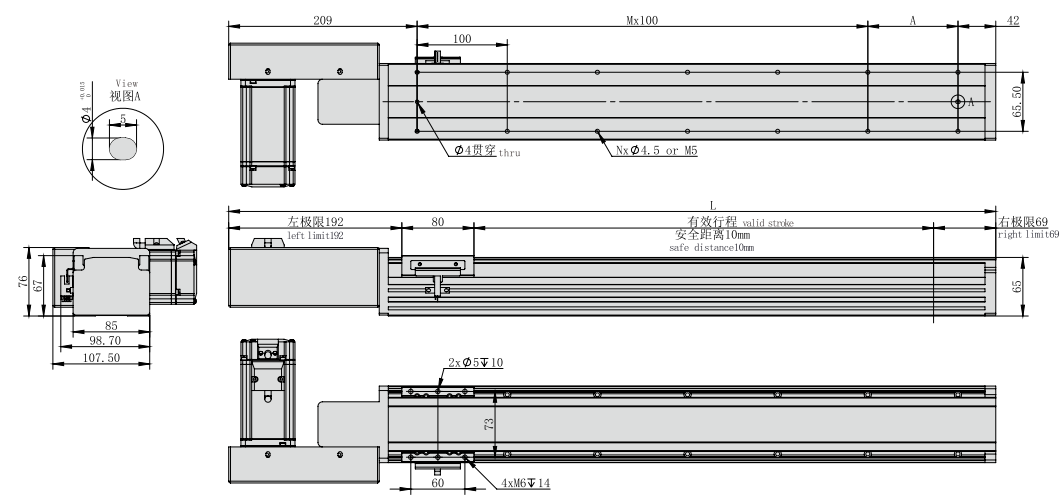

\*不含电机重量。\*Motor weight not included.

有效行程 Stroke	150	250	350	450	550	650	750	850	950	1050
L	501	601	701	801	901	1001	1101	1201	1301	1401
A	50	50	50	50	50	50	50	50	50	50
N	8	10	12	14	16	18	20	22	24	26
M	2	3	4	5	6	7	8	9	10	11
KG	3.2	3.6	4	4.4	4.8	5.2	5.6	6	6.4	6.8

如有超长行程及定制需求,请咨询我司业务。If you have extra long trip and custom requirements, please consult our business.

LU 电机外置左上 Motor external upper left

单位:Unit: mm

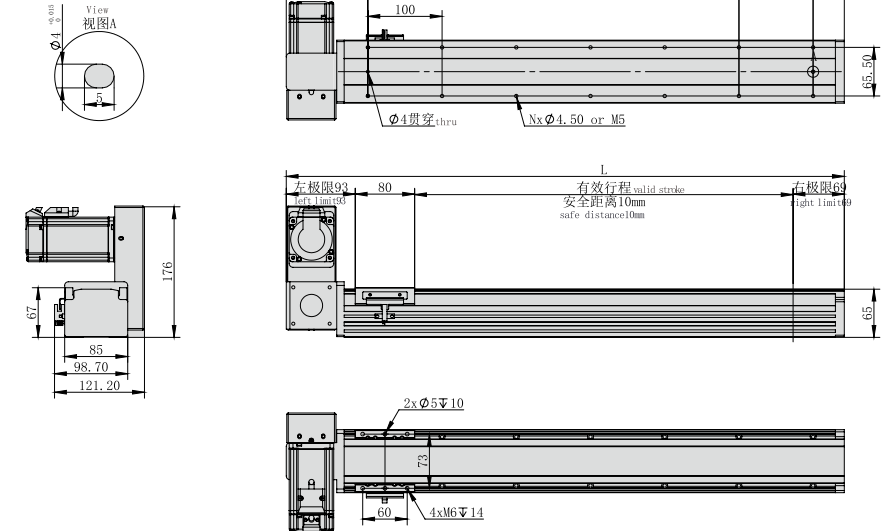

\*不含电机重量。\*Motor weight not included.

有效行程 Stroke	150	250	350	450	550	650	750	850	950	1050
L	402	502	602	702	802	902	1002	1102	1202	1302
A	50	50	50	50	50	50	50	50	50	50
N	8	10	12	14	16	18	20	22	24	26
M	2	3	4	5	6	7	8	9	10	11
KG	3.2	3.6	4	4.4	4.8	5.2	5.6	6	6.4	6.8

如有超长行程及定制需求,请咨询我司业务。If you have extra long trip and custom requirements, please consult our business.

- HNR
- HCR
- HNB
- HCB
- HNT
- XYZ
- ONB
- OCB
- GCR
- GCB
- GCBS
- GCRS
- ESR
- EMR
- EHR
- KSR
- LNP
- DDR

参考资料  
Reference data





电机外置右下/电机外置右上  
Motor external lower right / Motor external upper right

RP 电机外置右下 Motor external lower right

单位:Unit: mm

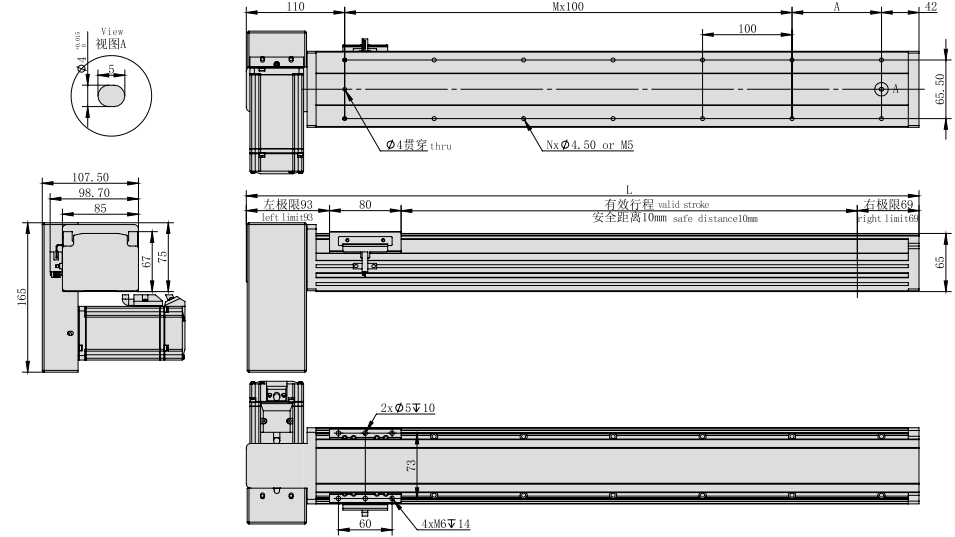

\*不含电机重量。\*Motor weight not included.

有效行程 Stroke	150	250	350	450	550	650	750	850	950	1050
L	402	502	602	702	802	902	1002	1102	1202	1302
A	50	50	50	50	50	50	50	50	50	50
N	8	10	12	14	16	18	20	22	24	26
M	2	3	4	5	6	7	8	9	10	11
KG	3.2	3.6	4	4.4	4.8	5.2	5.6	6	6.4	6.8

如有超长行程及定制需求, 请咨询我司业务。If you have extra long trip and custom requirements, please consult our business.

RU 电机外置右上 Motor external upper right

单位:Unit: mm

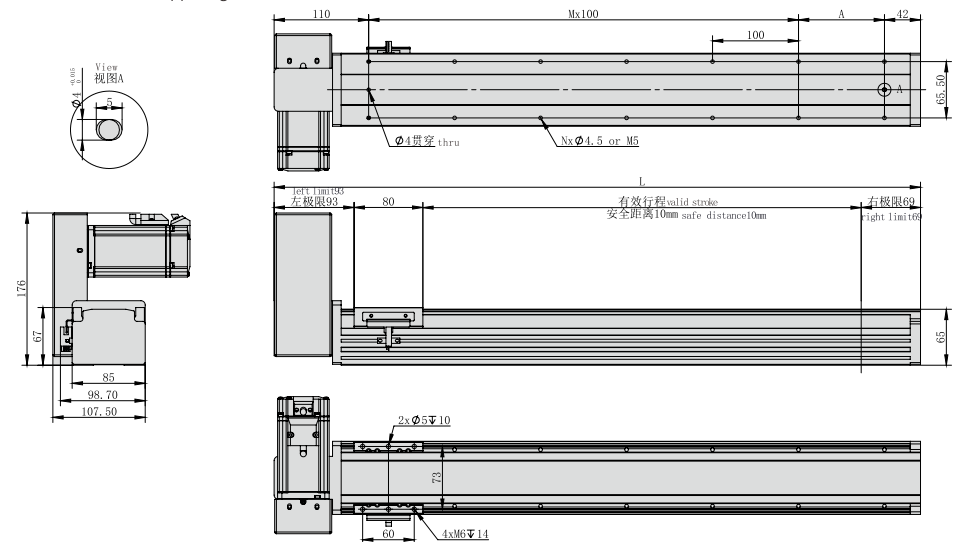

\*不含电机重量。\*Motor weight not included.

有效行程 Stroke	150	250	350	450	550	650	750	850	950	1050
L	402	502	602	702	802	902	1002	1102	1202	1302
A	50	50	50	50	50	50	50	50	50	50
N	8	10	12	14	16	18	20	22	24	26
M	2	3	4	5	6	7	8	9	10	11
KG	3.2	3.6	4	4.4	4.8	5.2	5.6	6	6.4	6.8

如有超长行程及定制需求, 请咨询我司业务。If you have extra long trip and custom requirements, please consult our business.

MEMO

HNR

HCR

HNB

HCB

HNT

XYZ

ONB

OCB

GCR

GCB

GCBS

GCRS

ESR

EMR

EHR

KSR

LNP

DDR

参考资料  
Reference data



重复精度  
Repeat Accuracy  
±0.04  
mm

此图仅供参考, 出货规格详见尺寸图面  
This picture for reference only, specs details according with the drawing.

最大行程  
Max stroke 3050mm

最高速度  
Max speed 4500mm/s

马达容量  
Motor output 200W

直线导轨  
Linear guide 20X18-2支

型号表达方式 Ordering method

TPA-HNB-105D-90-L3050-MR-Y-P20-N3-F

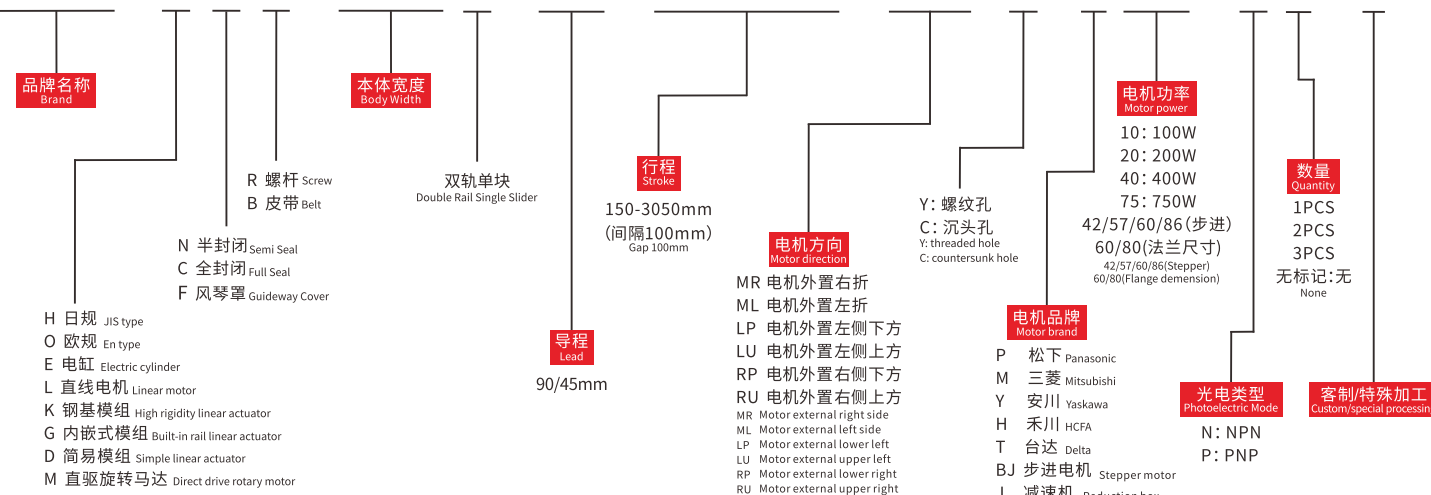

产品性能参数如下 Product performance parameters are as follows

规格 Spec	电机功率 (W) Motor power (W)	200	
	重复定位精度 (mm) Repeated positioning accuracy (mm)	±0.04	
	减速比 (mm) Reduction ratio	1:1	1:2
	导程 (mm) Lead (mm)	90	45
	最高速度 (mm/s) Maximum speed (mm/s)	4500	
	电机额定转速 (RPM) Rated speed of motor (RPM)	3000	
最大可搬重量 Maximum Payload	9	18	
	标准行程 (mm) Stroke pitch (mm)	150~3050mm/100 间隔100 mm Pitch	
部品 Parts	基座材质 Material of base	硬质挤压铝材A1 Hard extruded aluminum A1	
	使用环境 Operating environment	0~40°C, 85%RH(无凝结) No condensation	

注1: 使用非上述功率电机时请依据实际参数推算。  
Note 1: When using a motor with a power other than the above, please calculate according to the actual parameters.

注2: 最高速度因行程和负载而异, 当螺杆细长比大于1:50时, 可能会因螺杆临界速度产生共振和抖动, 应适当下调运行速度, 一般螺杆每增长100mm, 速度应下调10~15%。  
Note 2: The maximum speed varies with stroke and load. When the screw slenderness ratio is greater than 1:50, resonance and jitter may occur due to the critical speed of the screw, so the running speed should be reduced appropriately. Generally, the speed should be reduced by 10~15% for every 100mm increase of the screw.

容许负载力矩表 N.m Allowable overhang

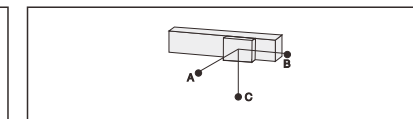
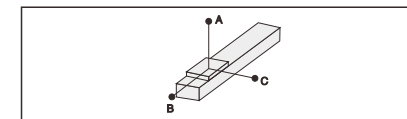

(单位Unit:mm)				(单位Unit:mm)					
水平安装 Horizontal installation	A	B	C	侧面安装 Side mounting	A	B	C		
负载 Load	5kg	495	152	128	负载 Load	4kg	162	192	625
	8kg	301	91	77		7kg	89	106	347
	10kg	236	71	60		10kg	60	71	236

传感器连接图<原点及端点> Sensor layout

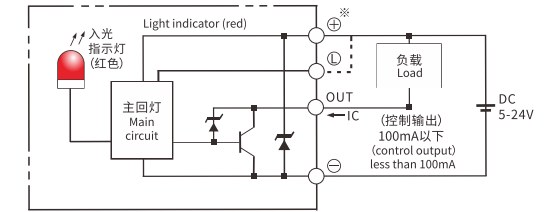

- HNR
- HCR
- HNB
- HCB
- HNT
- XYZ
- ONB
- OCB
- GCR
- GCB
- GCBS
- GCRS
- ESR
- EMR
- EHR
- KSR
- LNP
- DDR
- 参考资料  
Reference data

静态容许负载惯量 Static loading moment

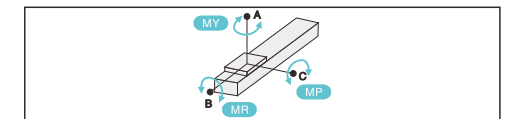

(单位Unit:N.m)	
MY	150
MP	150
MR	130

\*力矩表所表示的数据, 代表重心。  
The torque value in the chart indicate the center of gravity.  
\*符合型录规范的正常试用下, 保证寿命为10000公里。  
Operation life is 10,000km when the product is using under the specified conditions.  
\*倒吊使用无法套用标准规范, 如有需求请咨询我司业务。  
The standard specification cannot be applied to the use of inverted crane. Please consult our business if necessary.

搭配伺服马达一览表 Suitable motor brand

品牌 Brand	马达记号 Mark	刹车有无 Brake	马达容量 Motor capacity	电源电压 AC-Voltage	伺服马达型号 Servo motor model	驱动器型号 Driver Model
三菱 Mitsubishi	M	无刹车(水平式样) No brake (horizontal type)	200	220	HG-KR73	MR-J4-70A
松下 Panasonic	P	无刹车(水平式样) No brake (horizontal type)	200	220	MHMD082G1U	MBDHT3520
台达 Delta	T	无刹车(水平式样) No brake (horizontal type)	200	220	ECMA-C20807ES	ASD-B20721-B





电机外置右下/电机外置右上  
Motor external lower right / Motor external upper right

RP 电机外置右下 Motor external lower right

单位:Unit: mm

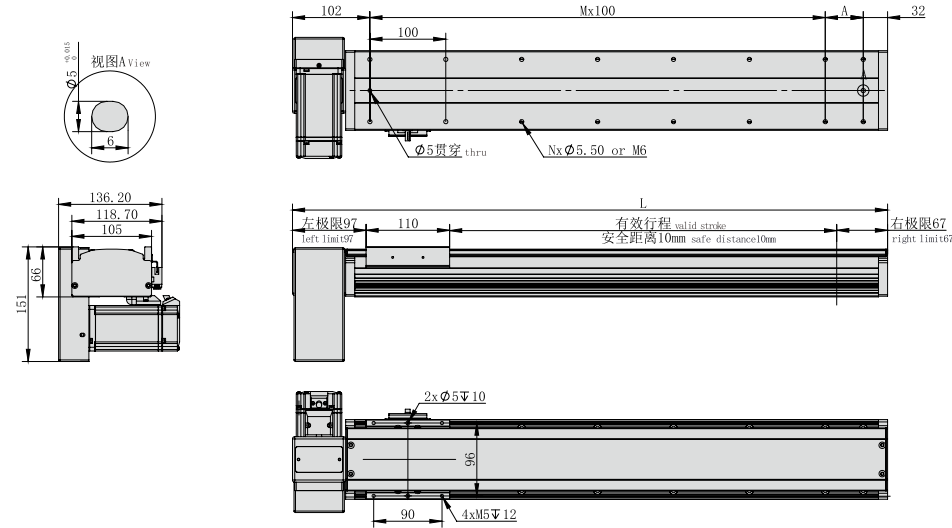

\*不含电机重量。\*Motor weight not included.

有效行程 Stroke	150	250	350	450	550	650	750	850	950	1050	1150	1250	1350	1450	1550	1650	1750	1850	1950	2050	2150	2250	2350	2450	2550	2650	2750	2850	2950	3050
L	434	534	634	734	834	934	1034	1134	1234	1334	1434	1534	1634	1734	1834	1934	2034	2134	2234	2334	2434	2534	2634	2734	2834	2934	3034	3134	3234	3334
A	100	100	100	100	100	100	100	100	100	100	100	100	100	100	100	100	100	100	100	100	100	100	100	100	100	100	100	100	100	100
N	8	10	12	14	16	18	20	22	24	26	28	30	32	34	36	38	40	42	44	46	48	50	52	54	56	58	60	62	64	66
M	3	4	5	6	7	8	9	10	11	12	13	14	15	16	17	18	19	20	21	22	23	24	25	26	27	28	29	30	31	32
KG	4.8	5.5	6.2	6.9	7.6	8.3	9	9.7	10.4	11.1	11.8	12.5	13.2	13.9	14.6	15.3	16	16.7	17.4	18.1	18.8	19.5	20.2	20.9	21.6	22.3	23	23.7	24.4	25.1

如有超长行程及定制需求,请咨询我司业务。If you have extra long trip and custom requirements, please consult our business.

RU 电机外置右上 Motor external upper right

单位:Unit: mm

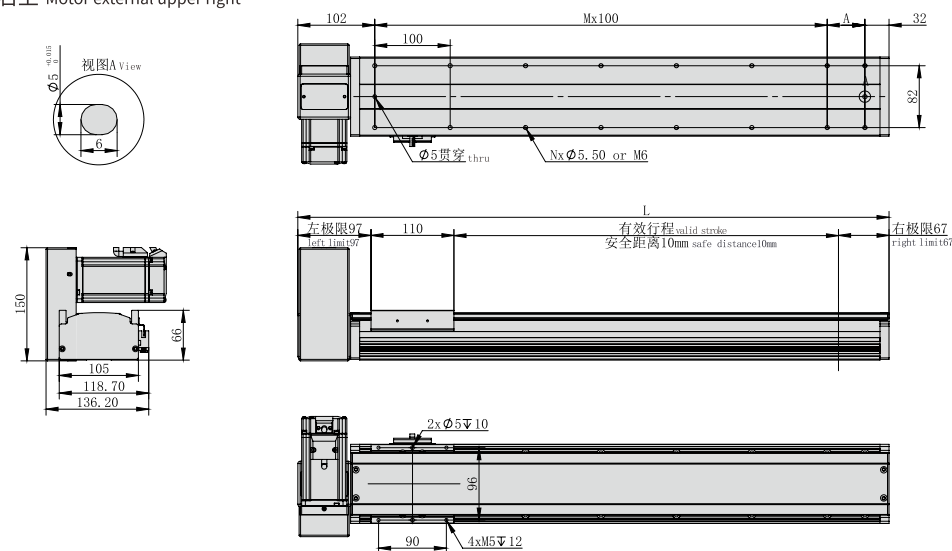

\*不含电机重量。\*Motor weight not included.

有效行程 Stroke	150	250	350	450	550	650	750	850	950	1050	1150	1250	1350	1450	1550	1650	1750	1850	1950	2050	2150	2250	2350	2450	2550	2650	2750	2850	2950	3050
L	434	534	634	734	834	934	1034	1134	1234	1334	1434	1534	1634	1734	1834	1934	2034	2134	2234	2334	2434	2534	2634	2734	2834	2934	3034	3134	3234	3334
A	100	100	100	100	100	100	100	100	100	100	100	100	100	100	100	100	100	100	100	100	100	100	100	100	100	100	100	100	100	100
N	8	10	12	14	16	18	20	22	24	26	28	30	32	34	36	38	40	42	44	46	48	50	52	54	56	58	60	62	64	66
M	3	4	5	6	7	8	9	10	11	12	13	14	15	16	17	18	19	20	21	22	23	24	25	26	27	28	29	30	31	32
KG	4.8	5.5	6.2	6.9	7.6	8.3	9	9.7	10.4	11.1	11.8	12.5	13.2	13.9	14.6	15.3	16	16.7	17.4	18.1	18.8	19.5	20.2	20.9	21.6	22.3	23	23.7	24.4	25.1

如有超长行程及定制需求,请咨询我司业务。If you have extra long trip and custom requirements, please consult our business.

MEMO

HNR

HCR

HNB

HCB

HNT

XYZ

ONB

OCB

GCR

GCB

GCBS

GCRS

ESR

EMR

EHR

KSR

LNP

DDR

参考资料  
Reference data



重复精度  
Repeat Accuracy  
±0.04  
mm

此图仅供参考, 出货规格详见尺寸图面  
This picture for reference only, specs details according with the drawing.

最大行程  
Max stroke 1850mm

最高速度  
Max speed 4500mm/s

马达容量  
Motor output 200W

直线导轨  
Linear guide 12X8-2支

型号表达方式 Ordering method

TPA-HNB-110D-90-L1850-MR-Y-P20-N3-F

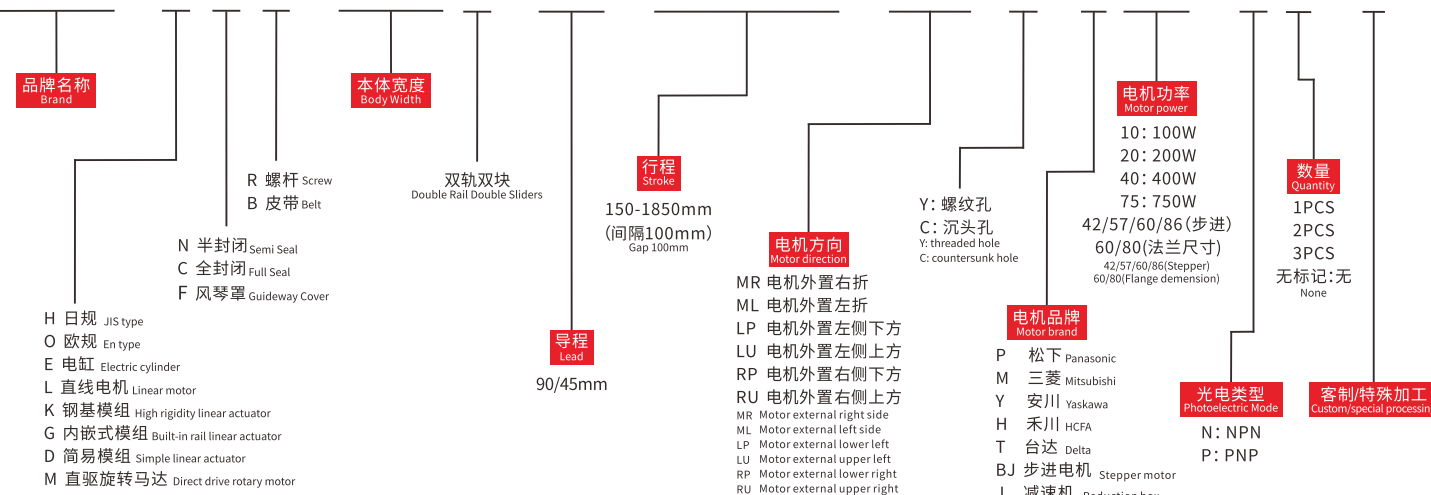

产品性能参数如下 Product performance parameters are as follows

规格 Spec	电机功率 (W) Motor power (W)	200	
	重复定位精度 (mm) Repeated positioning accuracy (mm)	±0.04	
	减速比 (mm) Reduction ratio	1:1	1:2
	导程 (mm) Lead (mm)	90	45
	最高速度 (mm/s) Maximum speed (mm/s)	4500	
	电机额定转速 (RPM) Rated speed of motor (RPM)	3000	
部 品 Parts	最大可搬重量 Maximum Payload	9	18
	标准行程 (mm) Stroke pitch (mm)	150~1850mm/100 间隔100 mm Pitch	
部 品 Parts	基座材质 Material of base	硬质挤压铝材A1 Hard extruded aluminum A1	
	使用环境 Operating environment	0~40°C, 85%RH(无凝结) No condensation	

注1: 使用非上述功率电机时请依据实际参数推算。  
Note 1: When using a motor with a power other than the above, please calculate according to the actual parameters.

注2: 最高速度因行程和负载而异, 当螺杆菌细长比大于1:50时, 可能会因螺杆菌临界速度产生共振和抖动, 应适当下调运行速度, 一般螺杆菌每增长100mm, 速度应下调10~15%。  
Note 2: The maximum speed varies with stroke and load. When the screw slenderness ratio is greater than 1:50, resonance and jitter may occur due to the critical speed of the screw, so the running speed should be reduced appropriately. Generally, the speed should be reduced by 10~15% for every 100mm increase of the screw.

传感器连接图<原点及端点> Sensor layout

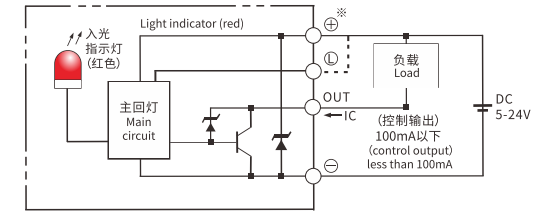

容许负载力矩表 N.m Allowable overhang

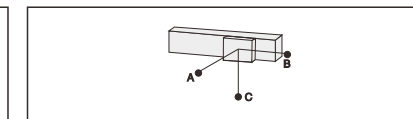
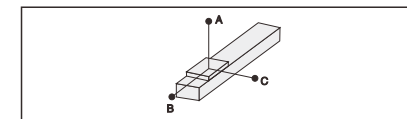

(单位Unit:mm)				(单位Unit:mm)					
水平安装 Horizontal installation		A	B	C	侧面安装 Side mounting		A	B	C
负 载 Load	5kg	1400	750	600	负 载 Load	5kg	660	500	1100
	8kg	1100	450	400		8kg	450	300	850
	10kg	1000	350	350		10kg	350	220	800

静态容许负载惯量 Static loading moment

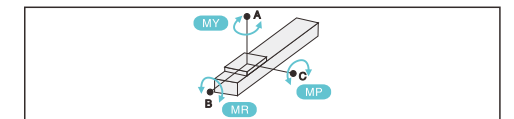

(单位Unit:N.m)	
MY	110
MP	110
MR	120

\*力矩表所表示的数据, 代表重心。  
The torque value in the chart indicate the center of gravity.  
\*符合录规范的正常使用下, 保证寿命为10000公里。  
Operation life is 10,000km when the product is using under the specified conditions.  
\*倒吊使用无法套用标准规范, 如有需求请咨询我司业务。  
The standard specification cannot be applied to the use of inverted crane. Please consult our business if necessary.

搭配伺服马达一览表 Suitable motor brand

品牌 Brand	马达记号 Mark	刹车有无 Brake	马达容量 Motor capacity	电源电压 AC-Voltage	伺服马达型号 Servo motor model	驱动器型号 Driver Model
三菱 Mitsubishi	M	无刹车(水平式样) No brake (horizontal type)	200	220	HG-KR73	MR-J4-70A
松下 Panasonic	P	无刹车(水平式样) No brake (horizontal type)	200	220	MHMD082G1U	MBDHT3520
台达 Delta	T	无刹车(水平式样) No brake (horizontal type)	200	220	ECMA-C20807ES	ASD-B20721-B



电机外置左侧/电机外置右侧  
Motor external left side / Motor external right side

ML 电机外置左侧 Motor external left side

单位:Unit: mm

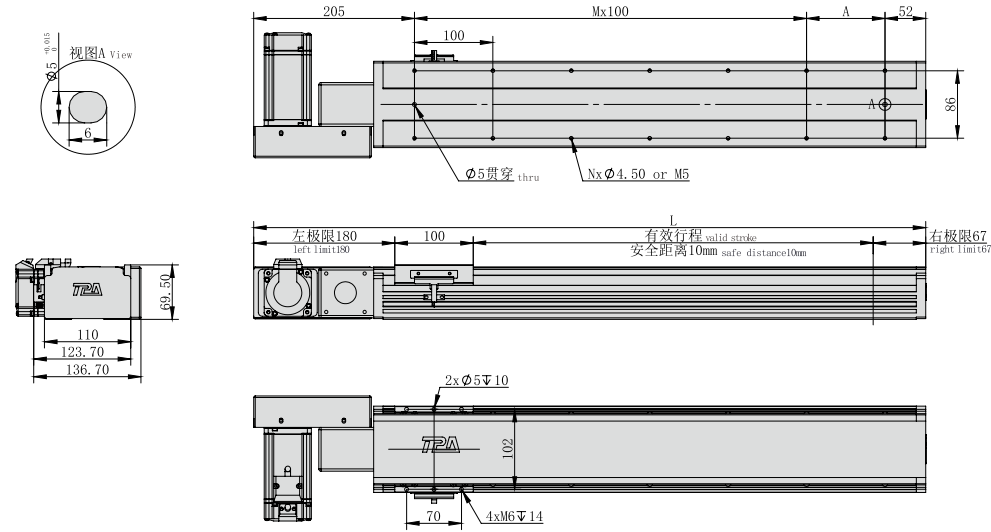

\*不含电机重量。\*Motor weight not included.

有效行程 Stroke	150	250	350	450	550	650	750	850	950	1050	1150	1250	1350	1450	1550	1650	1750	1850
L	507	607	707	807	907	1007	1107	1207	1307	1407	1507	1607	1707	1807	1907	2007	2107	2207
A	50	50	50	50	50	50	50	50	50	50	50	50	50	50	50	50	50	50
N	8	10	12	14	16	18	20	22	24	26	28	30	32	34	36	38	40	42
M	2	3	4	5	6	7	8	9	10	11	12	13	14	15	16	17	18	19
KG	4.5	5	5.5	6	6.5	7	7.5	8	8.5	9	9.5	10	10.5	11	11.5	12	12.5	13

如有超长行程及定制需求,请咨询我司业务。If you have extra long trip and custom requirements, please consult our business.

电机外置左下/电机外置左上  
Motor external lower left / Motor external upper left

LP 电机外置左下 Motor external lower left

单位:Unit: mm

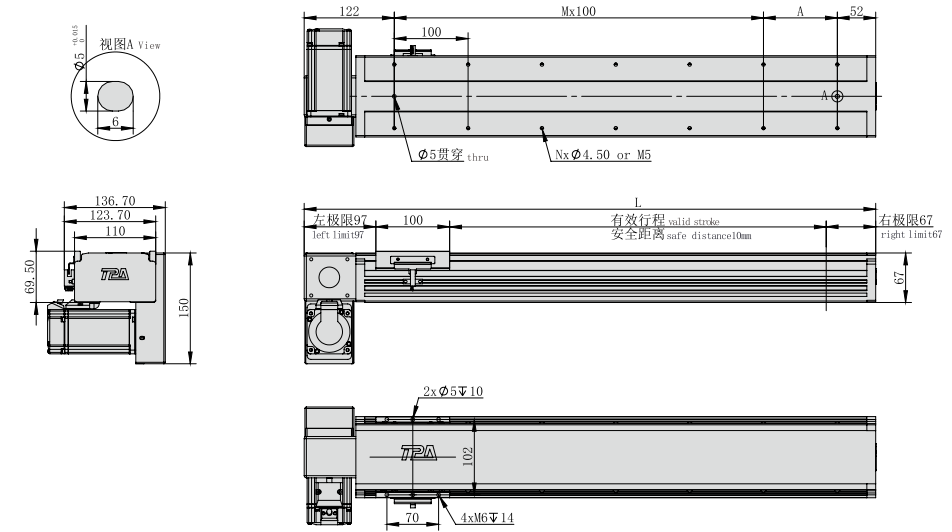

\*不含电机重量。\*Motor weight not included.

有效行程 Stroke	150	250	350	450	550	650	750	850	950	1050	1150	1250	1350	1450	1550	1650	1750	1850
L	424	524	624	724	824	924	1024	1124	1224	1324	1424	1524	1624	1724	1824	1924	2024	2124
A	50	50	50	50	50	50	50	50	50	50	50	50	50	50	50	50	50	50
N	8	10	12	14	16	18	20	22	24	26	28	30	32	34	36	38	40	42
M	2	3	4	5	6	7	8	9	10	11	12	13	14	15	16	17	18	19
KG	4.5	5	5.5	6	6.5	7	7.5	8	8.5	9	9.5	10	10.5	11	11.5	12	12.5	13

如有超长行程及定制需求,请咨询我司业务。If you have extra long trip and custom requirements, please consult our business.

MR 电机外置右侧 Motor external right side

单位:Unit: mm

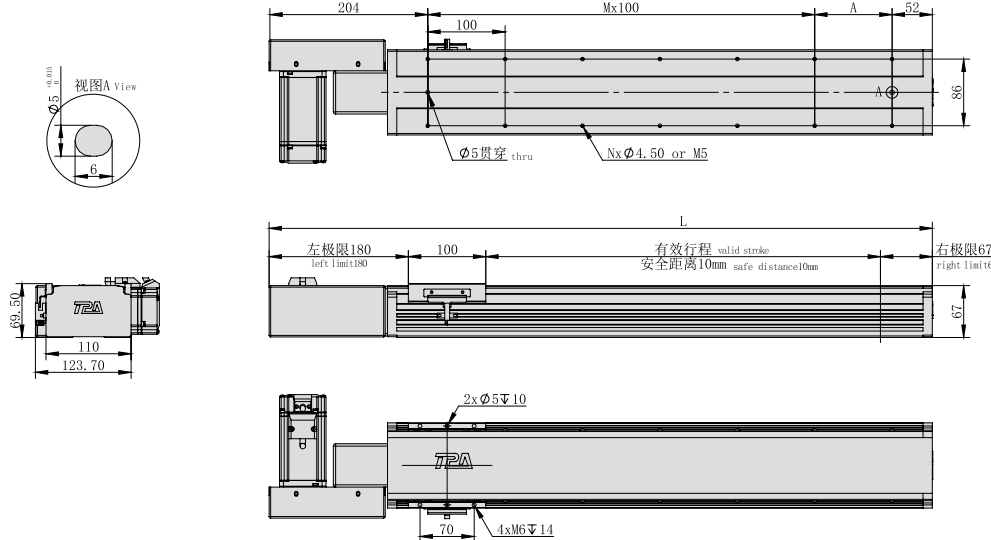

\*不含电机重量。\*Motor weight not included.

有效行程 Stroke	150	250	350	450	550	650	750	850	950	1050	1150	1250	1350	1450	1550	1650	1750	1850
L	507	607	707	807	907	1007	1107	1207	1307	1407	1507	1607	1707	1807	1907	2007	2107	2207
A	50	50	50	50	50	50	50	50	50	50	50	50	50	50	50	50	50	50
N	8	10	12	14	16	18	20	22	24	26	28	30	32	34	36	38	40	42
M	2	3	4	5	6	7	8	9	10	11	12	13	14	15	16	17	18	19
KG	4.5	5	5.5	6	6.5	7	7.5	8	8.5	9	9.5	10	10.5	11	11.5	12	12.5	13

如有超长行程及定制需求,请咨询我司业务。If you have extra long trip and custom requirements, please consult our business.

LU 电机外置左上 Motor external upper left

单位:Unit: mm

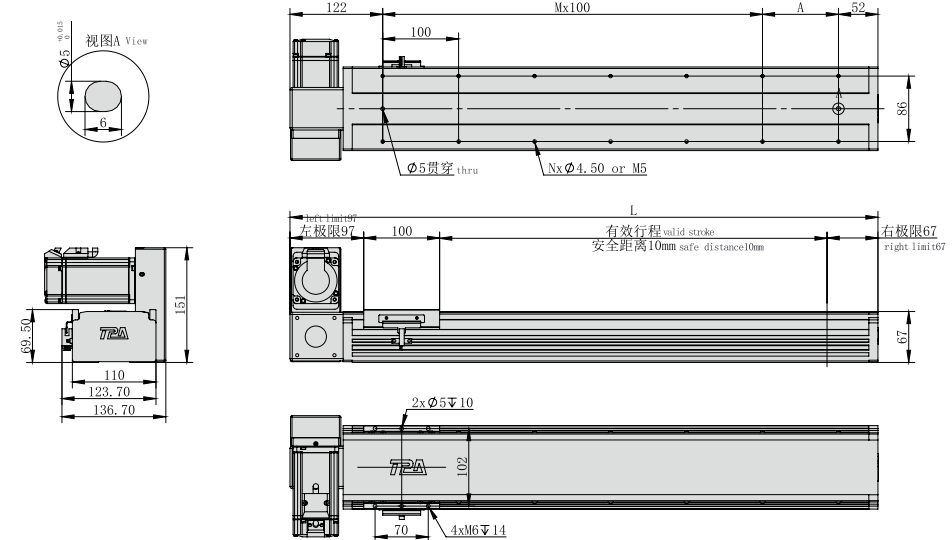

\*不含电机重量。\*Motor weight not included.

有效行程 Stroke	150	250	350	450	550	650	750	850	950	1050	1150	1250	1350	1450	1550	1650	1750	1850
L	424	524	624	724	824	924	1024	1124	1224	1324	1424	1524	1624	1724	1824	1924	2024	2124
A	50	50	50	50	50	50	50	50	50	50	50	50	50	50	50	50	50	50
N	8	10	12	14	16	18	20	22	24	26	28	30	32	34	36	38	40	42
M	2	3	4	5	6	7	8	9	10	11	12	13	14	15	16	17	18	19
KG	4.5	5	5.5	6	6.5	7	7.5	8	8.5	9	9.5	10	10.5	11	11.5	12	12.5	13

如有超长行程及定制需求,请咨询我司业务。If you have extra long trip and custom requirements, please consult our business.

- HNR
- HCR
- HNB
- HCB
- HNT
- XYZ
- ONB
- OCB
- GCR
- GCB
- GCBS
- GCRS
- ESR
- EMR
- EHR
- KSR
- LNP
- DDR

参考资料  
Reference data



电机外置右下/电机外置右上  
Motor external lower right / Motor external upper right

RP 电机外置右下 Motor external lower right

单位:Unit: mm

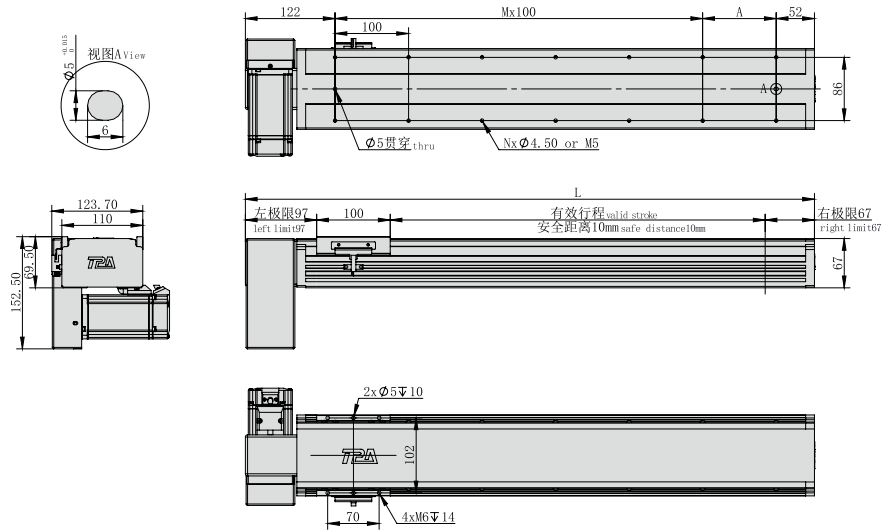

\*不含电机重量。\*Motor weight not included.

有效行程 Stroke	150	250	350	450	550	650	750	850	950	1050	1150	1250	1350	1450	1550	1650	1750	1850
L	424	524	624	724	824	924	1024	1124	1224	1324	1424	1524	1624	1724	1824	1924	2024	2124
A	50	50	50	50	50	50	50	50	50	50	50	50	50	50	50	50	50	50
N	8	10	12	14	16	18	20	22	24	26	28	30	32	34	36	38	40	42
M	2	3	4	5	6	7	8	9	10	11	12	13	14	15	16	17	18	19
KG	4.5	5	5.5	6	6.5	7	7.5	8	8.5	9	9.5	10	10.5	11	11.5	12	12.5	13

如有超长行程及定制需求,请咨询我司业务。If you have extra long trip and custom requirements, please consult our business.

RU 电机外置右上 Motor external upper right

单位:Unit: mm

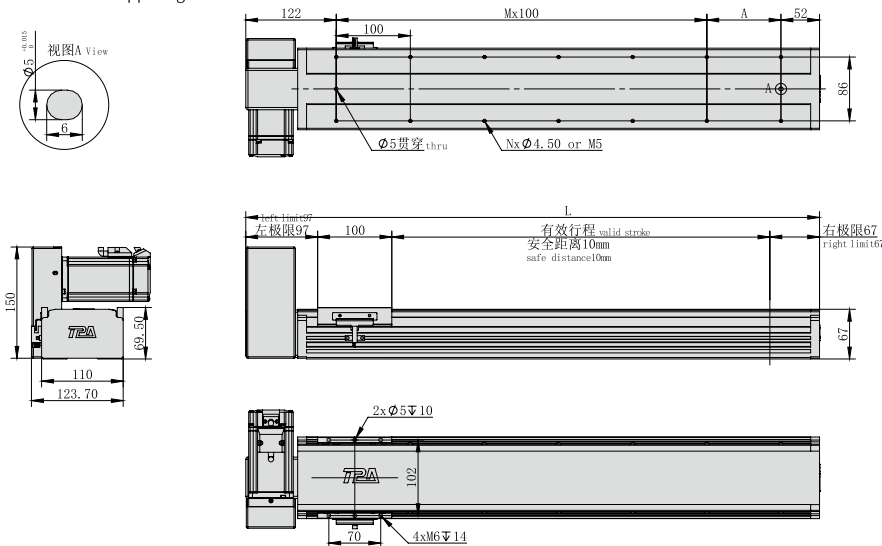

\*不含电机重量。\*Motor weight not included.

有效行程 Stroke	150	250	350	450	550	650	750	850	950	1050	1150	1250	1350	1450	1550	1650	1750	1850
L	424	524	624	724	824	924	1024	1124	1224	1324	1424	1524	1624	1724	1824	1924	2024	2124
A	50	50	50	50	50	50	50	50	50	50	50	50	50	50	50	50	50	50
N	8	10	12	14	16	18	20	22	24	26	28	30	32	34	36	38	40	42
M	2	3	4	5	6	7	8	9	10	11	12	13	14	15	16	17	18	19
KG	4.5	5	5.5	6	6.5	7	7.5	8	8.5	9	9.5	10	10.5	11	11.5	12	12.5	13

如有超长行程及定制需求,请咨询我司业务。If you have extra long trip and custom requirements, please consult our business.

MEMO

HNR

HCR

HNB

HCB

HNT

XYZ

ONB

OCB

GCR

GCB

GCBS

GCRS

ESR

EMR

EHR

KSR

LNP

DDR

参考资料

Reference

data



重复精度  
Repeat Accuracy  
±0.04  
mm

此图仅供参考, 出货规格详见尺寸图面  
This picture for reference only, specs details according with the drawing.

最大行程 Max stroke 3050mm    最高速度 Max speed 5500mm/s    马达容量 Motor output 400W    直线导轨 Linear guide 15X12.5-2支

型号表达方式 Ordering method

TPA-HNB-120D-110-L3050-MR-Y-P40-N3-F

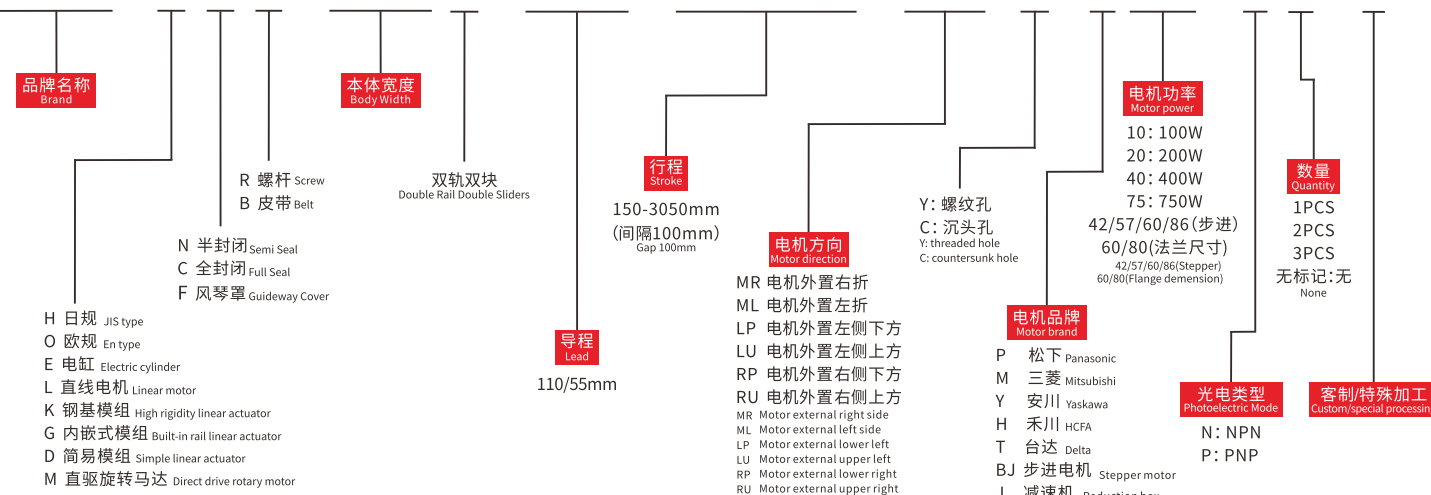

产品性能参数如下 Product performance parameters are as follows

电机功率 (W) Motor power (W)	400	
重复定位精度 (mm) Repeated positioning accuracy (mm)	±0.04	
减速比 (mm) Reduction ratio	1:1	1:2
规格 Spec 导程 (mm) Lead (mm)	110	55
最高速度 (mm/s) Maximum speed (mm/s)	5500	
电机额定转速 (RPM) Rated speed of motor (RPM)	3000	
最大可搬重量 Maximum Payload	14	28
标准行程 (mm) Stroke pitch (mm)	150~3050mm/100 间隔100 mm Pitch	
部 品 Parts 基座材质 Material of base	硬质挤压铝材A1 Hard extruded aluminum A1	
使用环境 Operating environment	0~40°C, 85%RH(无凝结) No condensation	

注1: 使用非上述功率电机时请依据实际参数推算。  
Note 1: When using a motor with a power other than the above, please calculate according to the actual parameters.  
注2: 最高速度因行程和负载而异, 当螺杆细长比大于1:50时, 可能会因螺杆临界速度产生共振和抖动, 应适当下调运行速度, 一般螺杆每增长100mm, 速度应下调10~15%。  
Note 2: The maximum speed varies with stroke and load. When the screw slenderness ratio is greater than 1:50, resonance and jitter may occur due to the critical speed of the screw, so the running speed should be reduced appropriately. Generally, the speed should be reduced by 10~15% for every 100mm increase of the screw.

传感器连接图<原点及端点> Sensor layout

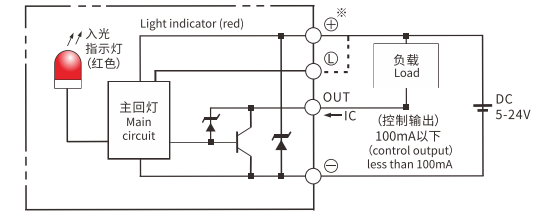

容许负载力矩表 N.m Allowable overhang

(单位Unit:mm)				(单位Unit:mm)					
水平安装 Horizontal installation	A	B	C	侧面安装 Side mounting	A	B	C		
负载 Load	5kg	1794	688	538	负载 Load	5kg	348	446	1170
	10kg	858	324	253		10kg	285	365	961
	20kg	670	251	197		20kg	197	251	670

静态容许负载惯量 Static loading moment

(单位Unit:N.m)	
MY	150
MP	150
MR	130

\*力矩表所表示的数据, 代表重心。  
The torque value in the chart indicate the center of gravity.  
\*符合型录规范的正常试用下, 保证寿命为10000公里。  
Operation life is 10,000km when the product is using under the specified conditions.  
\*倒吊使用无法套用标准规范, 如有需求请咨询我司业务。  
The standard specification cannot be applied to the use of inverted crane. Please consult our business if necessary.

搭配伺服马达一览表 Suitable motor brand

品牌 Brand	马达记号 Mark	刹车有无 Brake	马达容量 Motor capacity	电源电压 AC-Voltage	伺服马达型号 Servo motor model	驱动器型号 Driver Model
三菱 Mitsubishi	M	无刹车(水平式样) No brake (horizontal type)	200	220	HG-KR73	MR-J4-70A
松下 Panasonic	P	无刹车(水平式样) No brake (horizontal type)	200	220	MHMD082G1U	MBDHT3520
台达 Delta	T	无刹车(水平式样) No brake (horizontal type)	200	220	ECMA-C20807ES	ASD-B20721-B





### 电机外置左侧/电机外置右侧 Motor external left side / Motor external right side

#### ML 电机外置左侧 Motor external left side

单位:Unit: mm

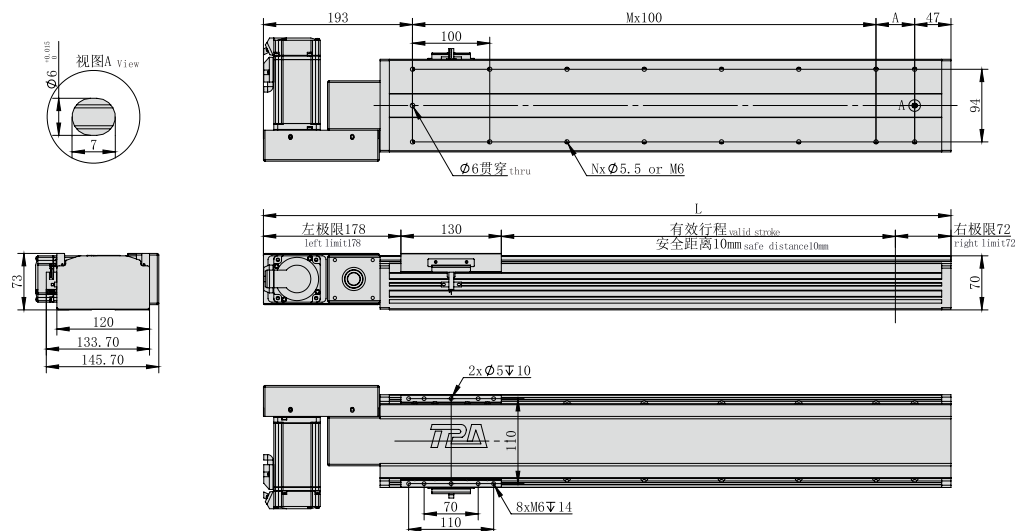

\*不含电机重量。\*Motor weight not included.

有效行程 Stroke	150	250	350	450	550	650	750	850	950	1050	1150	1250	1350	1450	1550	1650	1750	1850	1950	2050	2150	2250	2350	2450	2550	2650	2750	2850	2950	3050
L	540	640	740	840	940	1040	1140	1240	1340	1440	1540	1640	1740	1840	1940	2040	2140	2240	2340	2440	2540	2640	2740	2840	2940	3040	3140	3240	3340	3440
A	100	100	100	100	100	100	100	100	100	100	100	100	100	100	100	100	100	100	100	100	100	100	100	100	100	100	100	100	100	100
N	8	10	12	14	16	18	20	22	24	26	28	30	32	34	36	38	40	42	44	46	48	50	52	54	56	58	60	62	64	66
M	2	3	4	5	6	7	8	9	10	11	12	13	14	15	16	17	18	19	20	21	22	23	24	25	26	27	28	29	30	31
KG	7	8	9	10	11	12	13	14	15	16	17	18	19	20	21	22	23	24	25	26	27	28	29	30	31	32	33	34	35	36

如有超长行程及定制需求,请咨询我司业务。If you have extra long trip and custom requirements, please consult our business.

#### MR 电机外置右侧 Motor external right side

单位:Unit: mm

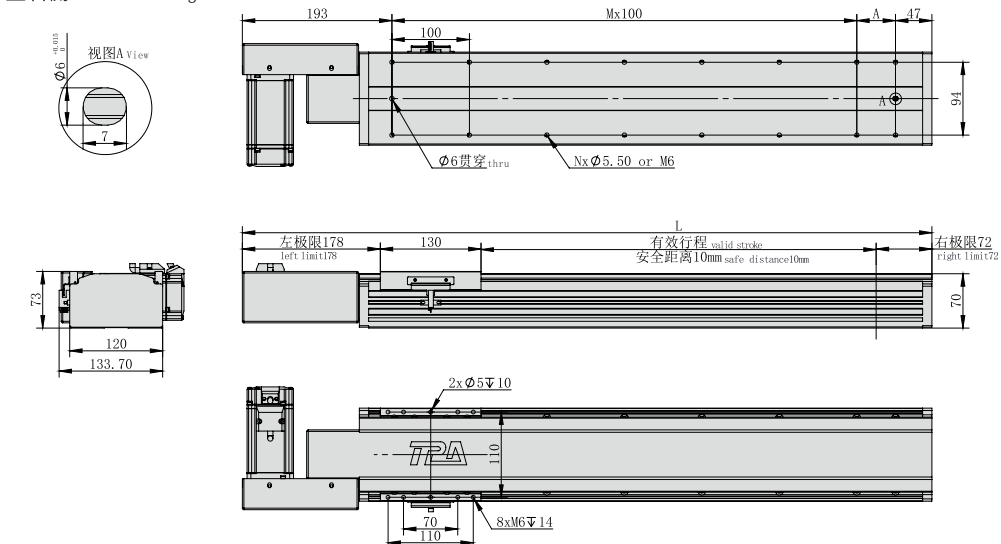

\*不含电机重量。\*Motor weight not included.

有效行程 Stroke	150	250	350	450	550	650	750	850	950	1050	1150	1250	1350	1450	1550	1650	1750	1850	1950	2050	2150	2250	2350	2450	2550	2650	2750	2850	2950	3050
L	540	640	740	840	940	1040	1140	1240	1340	1440	1540	1640	1740	1840	1940	2040	2140	2240	2340	2440	2540	2640	2740	2840	2940	3040	3140	3240	3340	3440
A	100	100	100	100	100	100	100	100	100	100	100	100	100	100	100	100	100	100	100	100	100	100	100	100	100	100	100	100	100	100
N	8	10	12	14	16	18	20	22	24	26	28	30	32	34	36	38	40	42	44	46	48	50	52	54	56	58	60	62	64	66
M	2	3	4	5	6	7	8	9	10	11	12	13	14	15	16	17	18	19	20	21	22	23	24	25	26	27	28	29	30	31
KG	7	8	9	10	11	12	13	14	15	16	17	18	19	20	21	22	23	24	25	26	27	28	29	30	31	32	33	34	35	36

如有超长行程及定制需求,请咨询我司业务。If you have extra long trip and custom requirements, please consult our business.

### 电机外置左下/电机外置左上 Motor external lower left / Motor external upper left

#### LP 电机外置左下 Motor external lower left

单位:Unit: mm

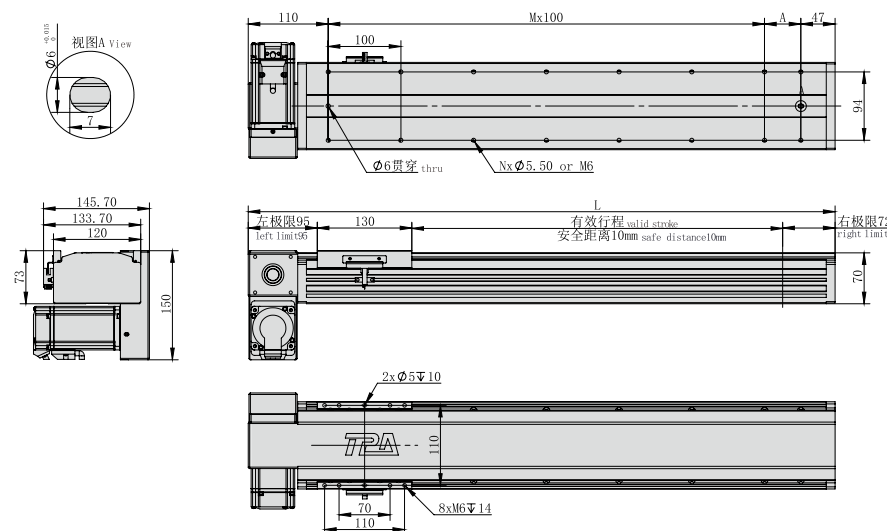

\*不含电机重量。\*Motor weight not included.

有效行程 Stroke	150	250	350	450	550	650	750	850	950	1050	1150	1250	1350	1450	1550	1650	1750	1850	1950	2050	2150	2250	2350	2450	2550	2650	2750	2850	2950	3050
L	457	557	657	757	857	957	1057	1157	1257	1357	1457	1557	1657	1757	1857	1957	2057	2157	2257	2357	2457	2557	2657	2757	2857	2957	3057	3157	3257	3357
A	100	100	100	100	100	100	100	100	100	100	100	100	100	100	100	100	100	100	100	100	100	100	100	100	100	100	100	100	100	100
N	8	10	12	14	16	18	20	22	24	26	28	30	32	34	36	38	40	42	44	46	48	50	52	54	56	58	60	62	64	66
M	2	3	4	5	6	7	8	9	10	11	12	13	14	15	16	17	18	19	20	21	22	23	24	25	26	27	28	29	30	31
KG	7	8	9	10	11	12	13	14	15	16	17	18	19	20	21	22	23	24	25	26	27	28	29	30	31	32	33	34	35	36

如有超长行程及定制需求,请咨询我司业务。If you have extra long trip and custom requirements, please consult our business.

#### LU 电机外置左上 Motor external upper left

单位:Unit: mm

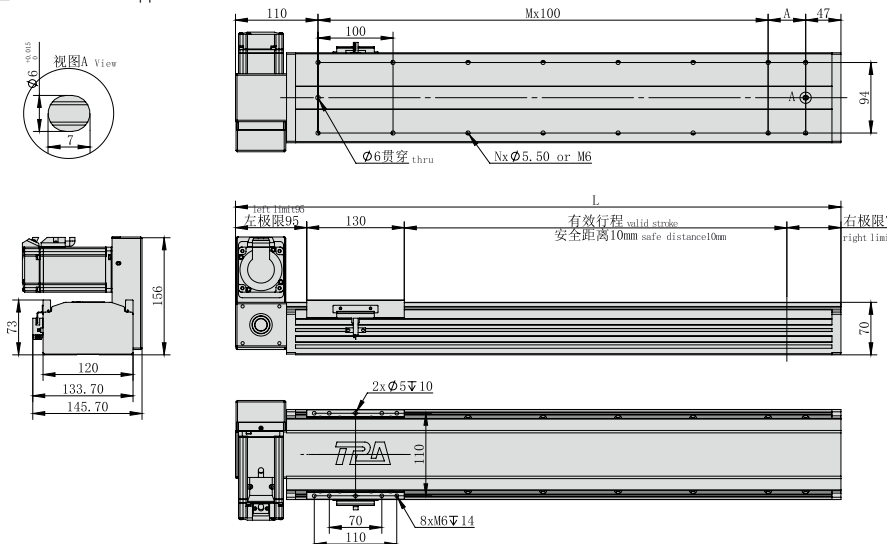

\*不含电机重量。\*Motor weight not included.

有效行程 Stroke	150	250	350	450	550	650	750	850	950	1050	1150	1250	1350	1450	1550	1650	1750	1850	1950	2050	2150	2250	2350	2450	2550	2650	2750	2850	2950	3050
L	457	557	657	757	857	957	1057	1157	1257	1357	1457	1557	1657	1757	1857	1957	2057	2157	2257	2357	2457	2557	2657	2757	2857	2957	3057	3157	3257	3357
A	100	100	100	100	100	100	100	100	100	100	100	100	100	100	100	100	100	100	100	100	100	100	100	100	100	100	100	100	100	100
N	8	10	12	14	16	18	20	22	24	26	28	30	32	34	36	38	40	42	44	46	48	50	52	54	56	58	60	62	64	66
M	2	3	4	5	6	7	8	9	10	11	12	13	14	15	16	17	18	19	20	21	22	23	24	25	26	27	28	29	30	31
KG	7	8	9	10	11	12	13	14	15	16	17	18	19	20	21	22	23	24	25	26	27	28	29	30	31	32	33	34	35	36

如有超长行程及定制需求,请咨询我司业务。If you have extra long trip and custom requirements, please consult our business.

- HNR
- HCR
- HNB
- HCB
- HNT
- XYZ
- ONB
- OCB
- GCR
- GCB
- GCBS
- GCRS
- ESR
- EMR
- EHR
- KSR
- LNP
- DDR

参考资料  
Reference data



电机外置右下/电机外置右上  
Motor external lower right / Motor external upper right

RP 电机外置右下 Motor external lower right

单位:Unit: mm

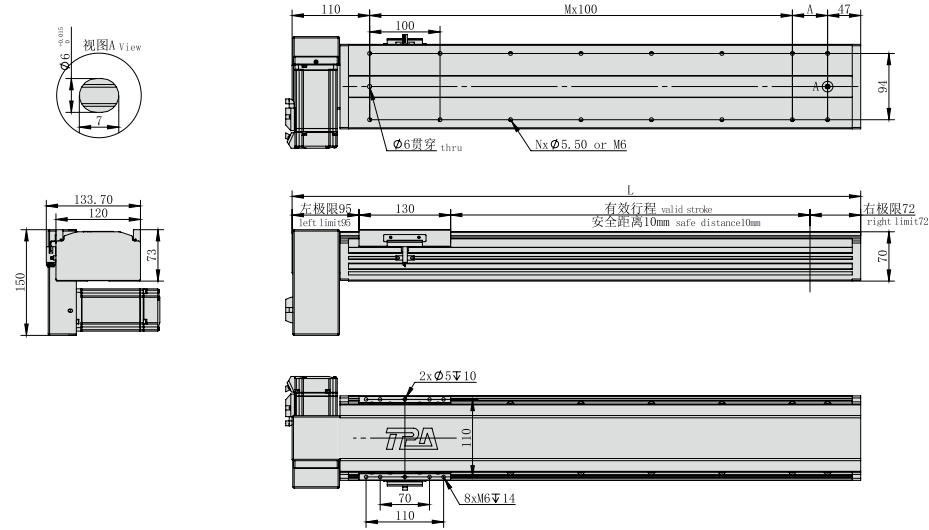

\*不含电机重量。\*Motor weight not included.

有效行程 Stroke	150	250	350	450	550	650	750	850	950	1050	1150	1250	1350	1450	1550	1650	1750	1850	1950	2050	2150	2250	2350	2450	2550	2650	2750	2850	2950	3050
L	457	557	657	757	857	957	1057	1157	1257	1357	1457	1557	1657	1757	1857	1957	2057	2157	2257	2357	2457	2557	2657	2757	2857	2957	3057	3157	3257	3357
A	100	100	100	100	100	100	100	100	100	100	100	100	100	100	100	100	100	100	100	100	100	100	100	100	100	100	100	100	100	100
N	8	10	12	14	16	18	20	22	24	26	28	30	32	34	36	38	40	42	44	46	48	50	52	54	56	58	60	62	64	66
M	2	3	4	5	6	7	8	9	10	11	12	13	14	15	16	17	18	19	20	21	22	23	24	25	26	27	28	29	30	31
KG	7	8	9	10	11	12	13	14	15	16	17	18	19	20	21	22	23	24	25	26	27	28	29	30	31	32	33	34	35	36

如有超长行程及定制需求,请咨询我司业务。If you have extra long trip and custom requirements, please consult our business.

RU 电机外置右上 Motor external upper right

单位:Unit: mm

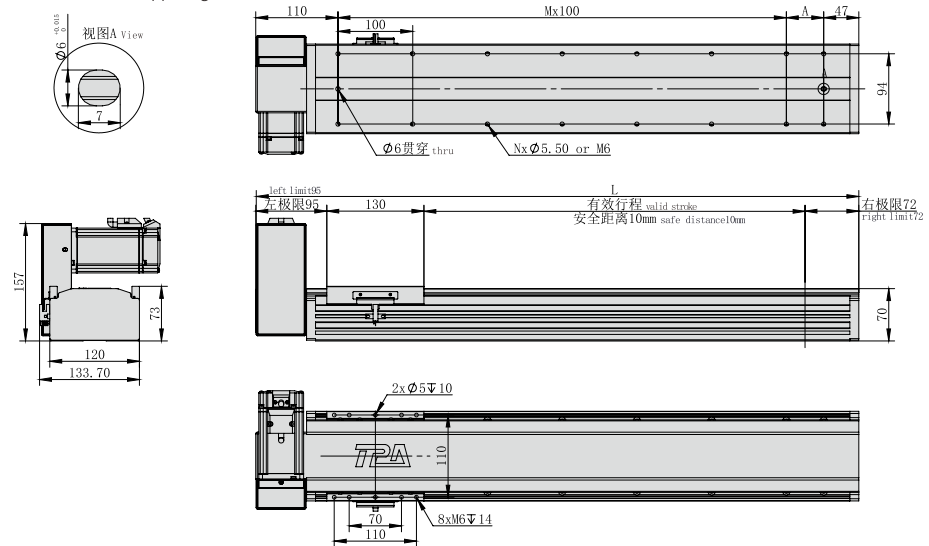

\*不含电机重量。\*Motor weight not included.

有效行程 Stroke	150	250	350	450	550	650	750	850	950	1050	1150	1250	1350	1450	1550	1650	1750	1850	1950	2050	2150	2250	2350	2450	2550	2650	2750	2850	2950	3050
L	457	557	657	757	857	957	1057	1157	1257	1357	1457	1557	1657	1757	1857	1957	2057	2157	2257	2357	2457	2557	2657	2757	2857	2957	3057	3157	3257	3357
A	100	100	100	100	100	100	100	100	100	100	100	100	100	100	100	100	100	100	100	100	100	100	100	100	100	100	100	100	100	100
N	8	10	12	14	16	18	20	22	24	26	28	30	32	34	36	38	40	42	44	46	48	50	52	54	56	58	60	62	64	66
M	2	3	4	5	6	7	8	9	10	11	12	13	14	15	16	17	18	19	20	21	22	23	24	25	26	27	28	29	30	31
KG	7	8	9	10	11	12	13	14	15	16	17	18	19	20	21	22	23	24	25	26	27	28	29	30	31	32	33	34	35	36

如有超长行程及定制需求,请咨询我司业务。If you have extra long trip and custom requirements, please consult our business.

MEMO

- HNR
- HCR
- HNB
- HCB
- HNT
- XYZ
- ONB
- OCB
- GCR
- GCB
- GCBS
- GCRS
- ESR
- EMR
- EHR
- KSR
- LNP
- DDR
- 参考资料  
Reference data



重复精度  
Repeat Accuracy  
**±0.04 mm**

此图仅供参考, 出货规格详见尺寸图面  
This picture for reference only, specs details according with the drawing.

最大行程 Max stroke: 3050mm | 最高速度 Max speed: 6000mm/s | 马达容量 Motor output: 400W | 直线导轨 Linear guide: 15X12.5-2支

型号表达方式 Ordering method

**TPA-HNB-140D-120-L3050-MR-Y-P40-N3-F**

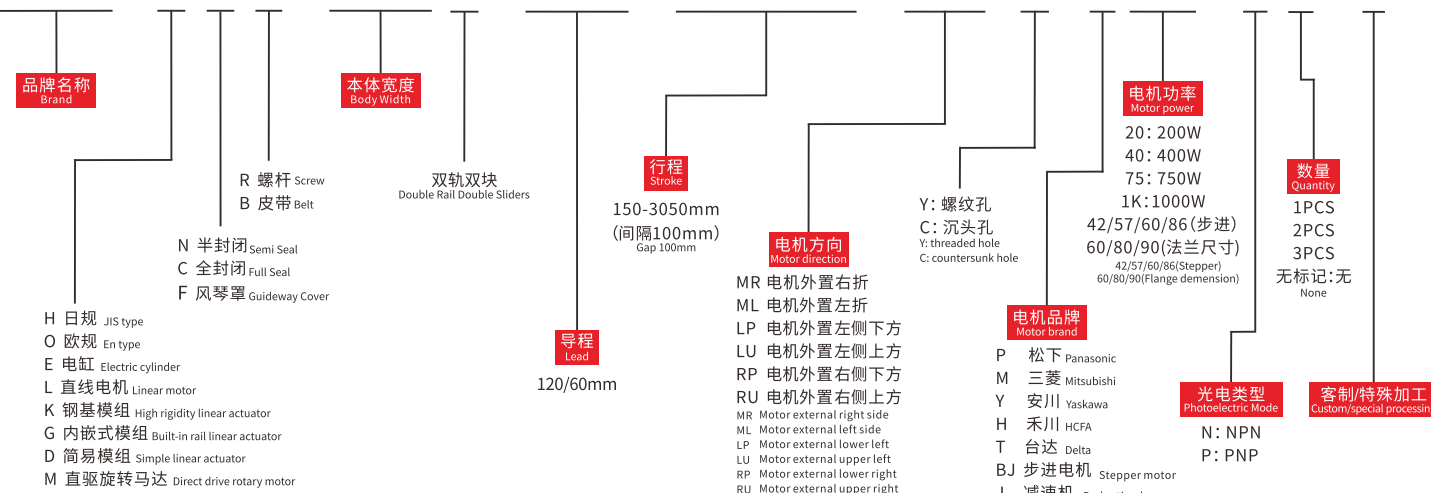

产品性能参数如下 Product performance parameters are as follows

规格 Spec	电机功率 (W) Motor power (W)	400	
	重复定位精度 (mm) Repeated positioning accuracy (mm)	±0.04	
	减速比 (mm) Reduction ratio	1:1	1:2
	导程 (mm) Lead (mm)	120	60
	最高速度 (mm/s) Maximum speed (mm/s)	6000	
	电机额定转速 (RPM) Rated speed of motor (RPM)	3000	
部 品 Parts	最大可搬重量 Maximum Payload	18	36
	标准行程 (mm) Stroke pitch (mm)	150~3050mm/100 间隔100 mm Pitch	
	基座材质 Material of base	硬质挤压铝材A1 Hard extruded aluminum A1	
使用环境 Operating environment	0~40°C, 85%RH(无凝结) No condensation		

注1: 使用非上述功率电机时请依据实际参数推算。  
Note 1: When using a motor with a power other than the above, please calculate according to the actual parameters.

注2: 最高速度因行程和负载而异, 当螺杆细长比大于1:50时, 可能会因螺杆临界速度产生共振和抖动, 应适当下调运行速度, 一般螺杆每增长100mm, 速度应下调10~15%。  
Note 2: The maximum speed varies with stroke and load. When the screw slenderness ratio is greater than 1:50, resonance and jitter may occur due to the critical speed of the screw, so the running speed should be reduced appropriately. Generally, the speed should be reduced by 10~15% for every 100mm increase of the screw.

容许负载力矩表 N.m Allowable overhang

(单位Unit:mm)				(单位Unit:mm)					
水平安装 Horizontal installation		A	B	C	侧面安装 Side mounting		A	B	C
负载 Load	5kg	2629	1279	1150	负载 Load	5kg	1365	1219	2339
	10kg	1559	719	712		10kg	699	649	1319
	20kg	1209	475	434		20kg	379	385	935
	32kg	766	310	288		32kg	199	220	600

传感器连接图<原点及端点> Sensor layout

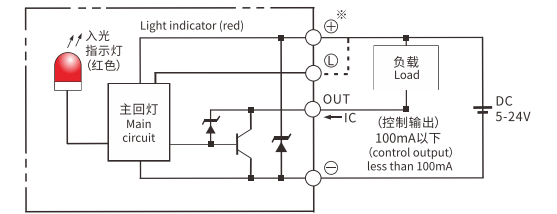

静态容许负载惯量 Static loading moment

(单位Unit:N.m)	
MY	551
MP	552
MR	485

\*力矩表所表示的数据, 代表重心。  
The torque value in the chart indicate the center of gravity.

\*符合型录规范的正常试用下, 保证寿命为10000公里。  
Operation life is 10,000km when the product is using under the specified conditions.

\*倒吊使用无法套用标准规范, 如有需求请咨询我司业务。  
The standard specification cannot be applied to the use of inverted crane. Please consult our business if necessary.

搭配伺服马达一览表 Suitable motor brand

品牌 Brand	马达记号 Mark	刹车有无 Brake	马达容量 Motor capacity	电源电压 AC-Voltage	伺服马达型号 Servo motor model	驱动器型号 Driver Model
三菱 Mitsubishi	M	无刹车(水平式样) No brake (horizontal type)	200	220	HG-KR73	MR-J4-70A
松下 Panasonic	P	无刹车(水平式样) No brake (horizontal type)	200	220	MHMD082G1U	MBDHT3520
台达 Delta	T	无刹车(水平式样) No brake (horizontal type)	200	220	ECMA-C20807ES	ASD-B20721-B



电机外置左侧/电机外置右侧  
Motor external left side / Motor external right side

ML 电机外置左侧 Motor external left side

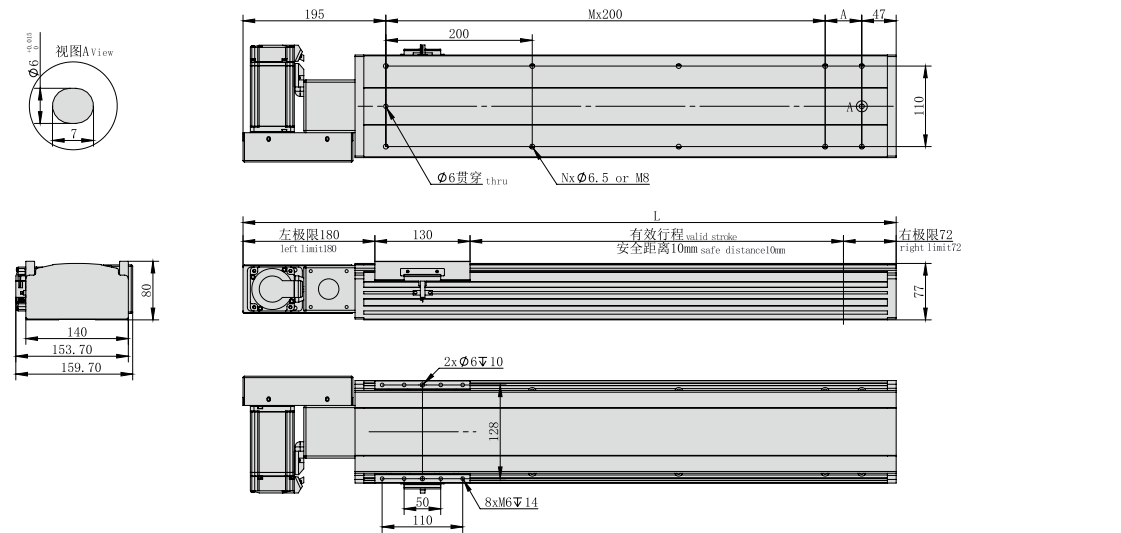

单位:Unit: mm

\*不含电机重量。\*Motor weight not included.

有效行程 Stroke	150	250	350	450	550	650	750	850	950	1050	1150	1250	1350	1450	1550	1650	1750	1850	1950	2050	2150	2250	2350	2450	2550	2650	2750	2850	2950	3050
L	542	642	742	842	942	1042	1142	1242	1342	1442	1542	1642	1742	1842	1942	2042	2142	2242	2342	2442	2542	2642	2742	2842	2942	3042	3142	3242	3342	3442
A	100	200	100	200	100	200	100	200	100	200	100	200	100	200	100	200	100	200	100	200	100	200	100	200	100	200	100	200	100	200
N	6	6	8	8	10	10	12	12	14	14	16	16	18	18	20	20	22	22	24	24	26	26	28	28	30	30	32	32	34	34
M	1	1	2	2	3	3	4	4	5	5	6	6	7	7	8	8	9	9	10	10	11	11	12	12	13	13	14	14	15	15
KG	8	8.5	9	9.5	10	10.5	11	11.5	12	12.5	13	13.5	14	14.5	15	15.5	16	16.5	17	17.5	18	18.5	19	19.5	20	20.5	21	21.5	22	22.5

如有超长行程及定制需求,请咨询我司业务。If you have extra long trip and custom requirements, please consult our business.

MR 电机外置右侧 Motor external right side

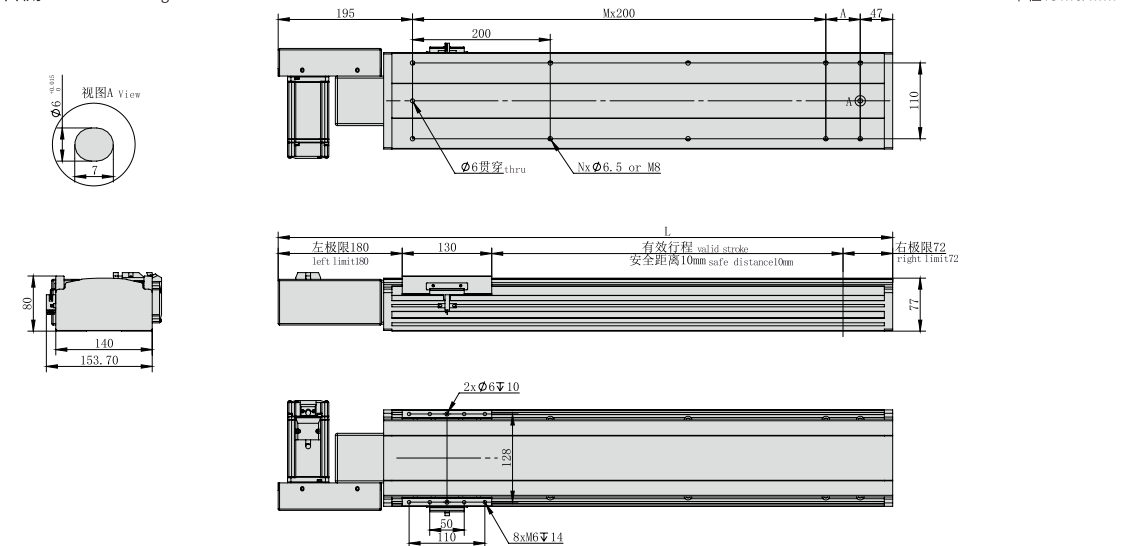

单位:Unit: mm

\*不含电机重量。\*Motor weight not included.

有效行程 Stroke	150	250	350	450	550	650	750	850	950	1050	1150	1250	1350	1450	1550	1650	1750	1850	1950	2050	2150	2250	2350	2450	2550	2650	2750	2850	2950	3050
L	542	642	742	842	942	1042	1142	1242	1342	1442	1542	1642	1742	1842	1942	2042	2142	2242	2342	2442	2542	2642	2742	2842	2942	3042	3142	3242	3342	3442
A	100	200	100	200	100	200	100	200	100	200	100	200	100	200	100	200	100	200	100	200	100	200	100	200	100	200	100	200	100	200
N	6	6	8	8	10	10	12	12	14	14	16	16	18	18	20	20	22	22	24	24	26	26	28	28	30	30	32	32	34	34
M	1	1	2	2	3	3	4	4	5	5	6	6	7	7	8	8	9	9	10	10	11	11	12	12	13	13	14	14	15	15
KG	8	8.5	9	9.5	10	10.5	11	11.5	12	12.5	13	13.5	14	14.5	15	15.5	16	16.5	17	17.5	18	18.5	19	19.5	20	20.5	21	21.5	22	22.5

如有超长行程及定制需求,请咨询我司业务。If you have extra long trip and custom requirements, please consult our business.

电机外置左下/电机外置左上  
Motor external lower left / Motor external upper left

LP 电机外置左下 Motor external lower left

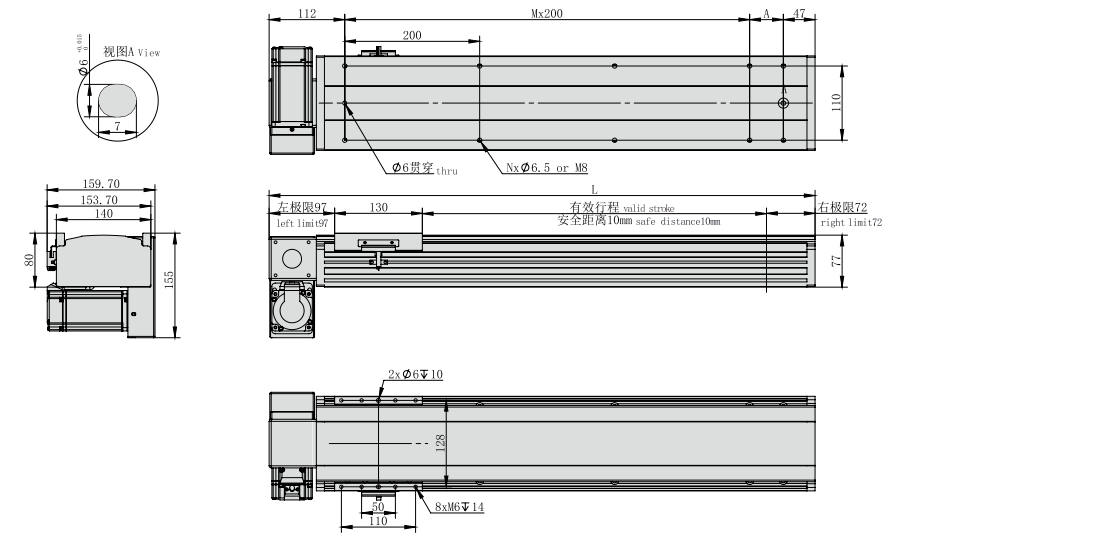

单位:Unit: mm

\*不含电机重量。\*Motor weight not included.

有效行程 Stroke	150	250	350	450	550	650	750	850	950	1050	1150	1250	1350	1450	1550	1650	1750	1850	1950	2050	2150	2250	2350	2450	2550	2650	2750	2850	2950	3050
L	459	559	659	759	859	959	1059	1159	1259	1359	1459	1559	1659	1759	1859	1959	2059	2159	2259	2359	2459	2559	2659	2759	2859	2959	3059	3159	3259	3359
A	100	200	100	200	100	200	100	200	100	200	100	200	100	200	100	200	100	200	100	200	100	200	100	200	100	200	100	200	100	200
N	6	6	8	8	10	10	12	12	14	14	16	16	18	18	20	20	22	22	24	24	26	26	28	28	30	30	32	32	34	34
M	1	1	2	2	3	3	4	4	5	5	6	6	7	7	8	8	9	9	10	10	11	11	12	12	13	13	14	14	15	15
KG	8	8.5	9	9.5	10	10.5	11	11.5	12	12.5	13	13.5	14	14.5	15	15.5	16	16.5	17	17.5	18	18.5	19	19.5	20	20.5	21	21.5	22	22.5

如有超长行程及定制需求,请咨询我司业务。If you have extra long trip and custom requirements, please consult our business.

LU 电机外置左上 Motor external upper left

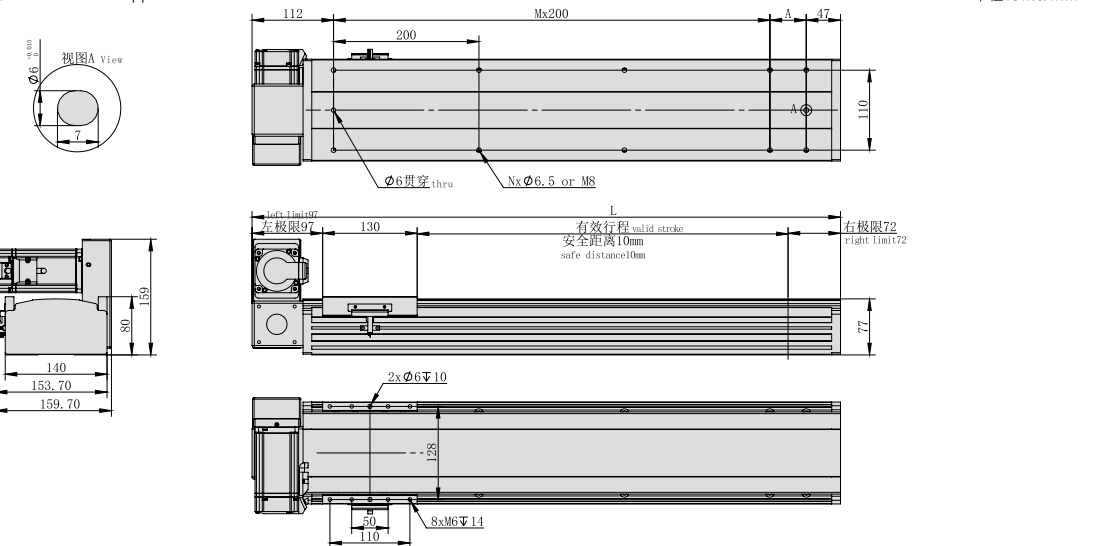

单位:Unit: mm

\*不含电机重量。\*Motor weight not included.

有效行程 Stroke	150	250	350	450	550	650	750	850	950	1050	1150	1250	1350	1450	1550	1650	1750	1850	1950	2050	2150	2250	2350	2450	2550	2650	2750	2850	2950	3050
L	459	559	659	759	859	959	1059	1159	1259	1359	1459	1559	1659	1759	1859	1959	2059	2159	2259	2359	2459	2559	2659	2759	2859	2959	3059	3159	3259	3359
A	100	200	100	200	100	200	100	200	100	200	100	200	100	200	100	200	100	200	100	200	100	200	100	200	100	200	100	200	100	200
N	6	6	8	8	10	10	12	12	14	14	16	16	18	18	20	20	22	22	24	24	26	26	28	28	30	30	32	32	34	34
M	1	1	2	2	3	3	4	4	5	5	6	6	7	7	8	8	9	9	10	10	11	11	12	12	13	13	14	14	15	15
KG	8	8.5	9	9.5	10	10.5	11	11.5	12	12.5	13	13.5	14	14.5	15	15.5	16	16.5	17	17.5	18	18.5	19	19.5	20	20.5	21	21.5	22	22.5

如有超长行程及定制需求,请咨询我司业务。If you have extra long trip and custom requirements, please consult our business.

- HNR
- HCR
- HNB
- HCB
- HNT
- XYZ
- ONB
- OCB
- GCR
- GCB
- GCBS
- GCRS
- ESR
- EMR
- EHR
- KSR
- LNP
- DDR

参考资料  
Reference data



电机外置右下/电机外置右上  
Motor external lower right / Motor external upper right

RP 电机外置右下 Motor external lower right

单位:Unit: mm

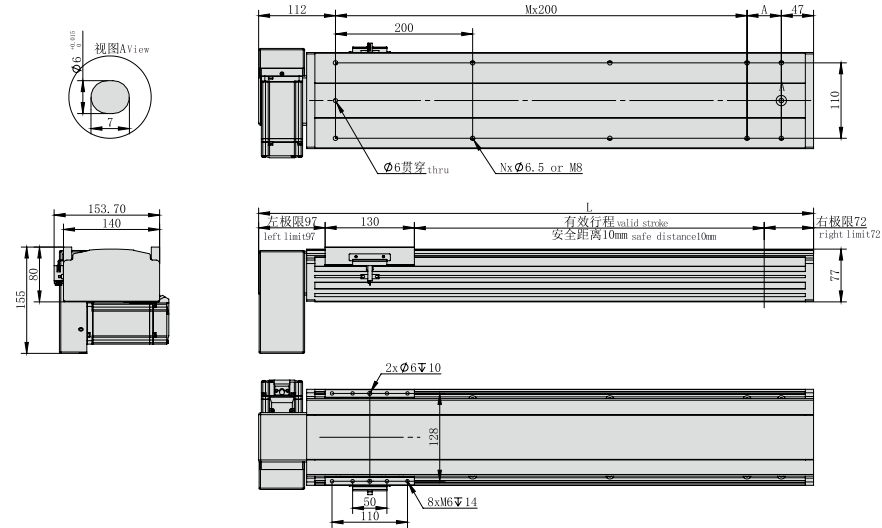

\*不含电机重量。\*Motor weight not included.

有效行程 Stroke	150	250	350	450	550	650	750	850	950	1050	1150	1250	1350	1450	1550	1650	1750	1850	1950	2050	2150	2250	2350	2450	2550	2650	2750	2850	2950	3050
L	459	559	659	759	859	959	1059	1159	1259	1359	1459	1559	1659	1759	1859	1959	2059	2159	2259	2359	2459	2559	2659	2759	2859	2959	3059	3159	3259	3359
A	100	200	100	200	100	200	100	200	100	200	100	200	100	200	100	200	100	200	100	200	100	200	100	200	100	200	100	200	100	200
N	6	6	8	8	10	10	12	12	14	14	16	16	18	18	20	20	22	22	24	24	26	26	28	28	30	30	32	32	34	34
M	1	1	2	2	3	3	4	4	5	5	6	6	7	7	8	8	9	9	10	10	11	11	12	12	13	13	14	14	15	15
KG	8	8.5	9	9.5	10	10.5	11	11.5	12	12.5	13	13.5	14	14.5	15	15.5	16	16.5	17	17.5	18	18.5	19	19.5	20	20.5	21	21.5	22	22.5

如有超长行程及定制需求,请咨询我司业务。If you have extra long trip and custom requirements, please consult our business.

RU 电机外置右上 Motor external upper right

单位:Unit: mm

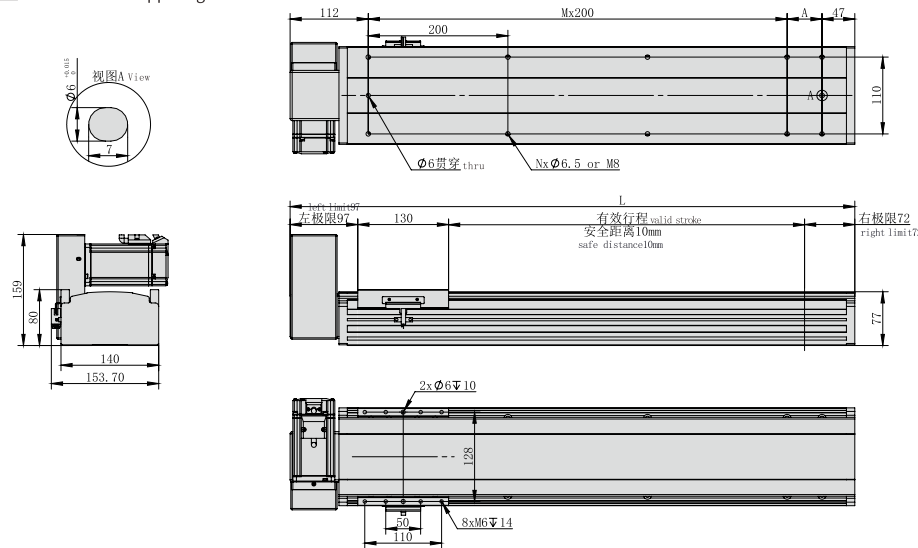

\*不含电机重量。\*Motor weight not included.

有效行程 Stroke	150	250	350	450	550	650	750	850	950	1050	1150	1250	1350	1450	1550	1650	1750	1850	1950	2050	2150	2250	2350	2450	2550	2650	2750	2850	2950	3050
L	459	559	659	759	859	959	1059	1159	1259	1359	1459	1559	1659	1759	1859	1959	2059	2159	2259	2359	2459	2559	2659	2759	2859	2959	3059	3159	3259	3359
A	100	200	100	200	100	200	100	200	100	200	100	200	100	200	100	200	100	200	100	200	100	200	100	200	100	200	100	200	100	200
N	6	6	8	8	10	10	12	12	14	14	16	16	18	18	20	20	22	22	24	24	26	26	28	28	30	30	32	32	34	34
M	1	1	2	2	3	3	4	4	5	5	6	6	7	7	8	8	9	9	10	10	11	11	12	12	13	13	14	14	15	15
KG	8	8.5	9	9.5	10	10.5	11	11.5	12	12.5	13	13.5	14	14.5	15	15.5	16	16.5	17	17.5	18	18.5	19	19.5	20	20.5	21	21.5	22	22.5

如有超长行程及定制需求,请咨询我司业务。If you have extra long trip and custom requirements, please consult our business.

MEMO

- HNR
- HCR
- HNB
- HCB
- HNT
- XYZ
- ONB
- OCB
- GCR
- GCB
- GCBS
- GCRS
- ESR
- EMR
- EHR
- KSR
- LNP
- DDR

参考资料  
Reference data



重复精度  
Repeat Accuracy  
±0.04  
mm

此图仅供参考, 出货规格详见尺寸图面  
This picture for reference only, specs details according with the drawing.

最大行程 Max stroke 3050mm    最高速度 Max speed 7000mm/s    马达容量 Motor output 750W    直线导轨 Linear guide 20X15.5-2支

型号表达方式 Ordering method

TPA-HNB-175D-140-L3050-MR-Y-P75-N3-F

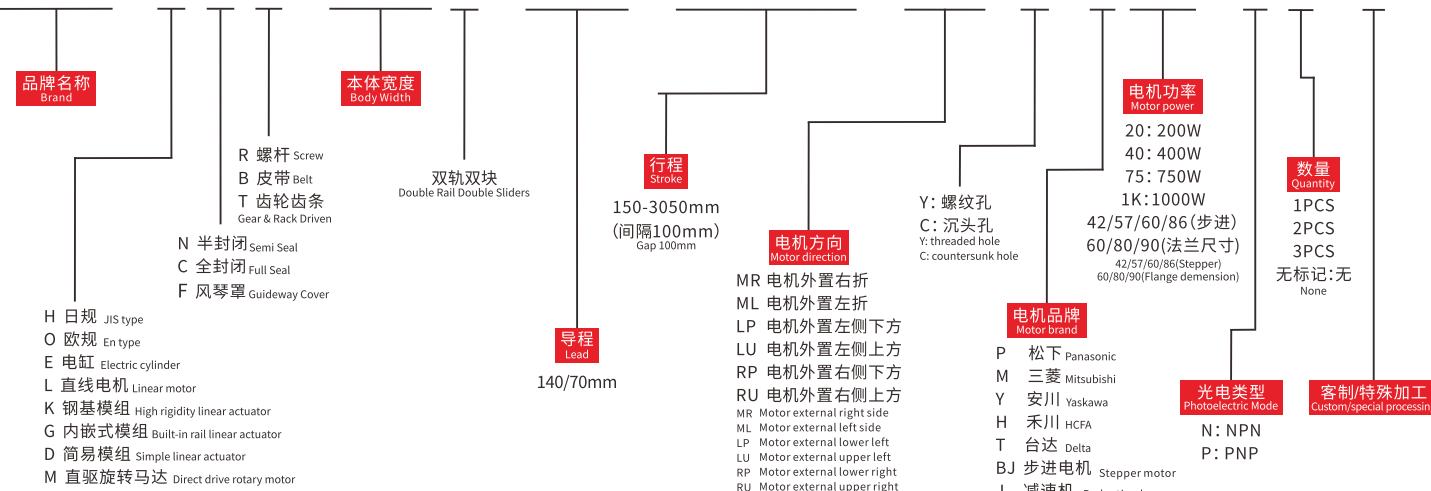

产品性能参数如下 Product performance parameters are as follows

规格 Spec	电机功率 (W) Motor power (W)	750	
	重复定位精度 (mm) Repeated positioning accuracy (mm)	±0.04	
	减速比 (mm) Reduction ratio	1:1	1:2
	导程 (mm) Lead (mm)	140	70
	最高速度 (mm/s) Maximum speed (mm/s)	7000	
	电机额定转速 (RPM) Rated speed of motor (RPM)	3000	
部 品 Parts	最大可搬重量 Maximum Payload	30	60
	标准行程 (mm) Stroke pitch (mm)	150~3050mm/100 间隔100 mm Pitch	
	基座材质 Material of base	硬质挤压铝材A1 Hard extruded aluminum A1	
使用环境 Operating environment	0~40°C, 85%RH(无凝结) No condensation		

注1: 使用非上述功率电机时请依据实际参数推算。  
Note 1: When using a motor with a power other than the above, please calculate according to the actual parameters.

注2: 最高速度因行程和负载而异, 当螺杆细长比大于1:50时, 可能会因螺杆临界速度产生共振和抖动, 应适当下调运行速度, 一般螺杆每增长100mm, 速度应下调10~15%。  
Note 2: The maximum speed varies with stroke and load. When the screw slenderness ratio is greater than 1:50, resonance and jitter may occur due to the critical speed of the screw, so the running speed should be reduced appropriately. Generally, the speed should be reduced by 10~15% for every 100mm increase of the screw.

传感器连接图<原点及端点> Sensor layout

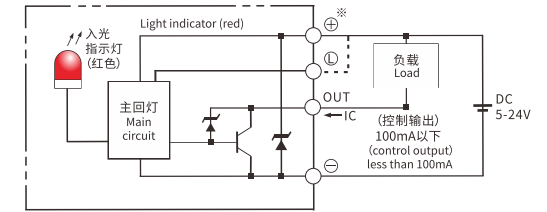

容许负载力矩表 N.m Allowable overhang



水平安装 Horizontal installation	负载 Load	A	B	C
		10kg	2942	1133
	20kg	1430	547	498
	30kg	926	350	320
	45kg	588	219	201

侧面安装 Side mounting	负载 Load	A	B	C
		15kg	676	742
	25kg	390	428	1127
	35kg	269	294	781
	45kg	201	219	588

静态容许负载惯量 Static loading moment

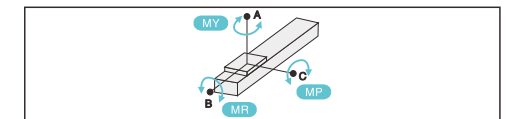

(单位Unit:N.m)

MY	1032
MP	1034
MR	908

\*力矩表所表示的数据, 代表重心。  
The torque value in the chart indicate the center of gravity.

\*符合型录规范的正常试用下, 保证寿命为10000公里。  
Operation life is 10,000km when the product is using under the specified conditions.

\*倒吊使用无法套用标准规范, 如有需求请咨询我司业务。  
The standard specification cannot be applied to the use of inverted crane. Please consult our business if necessary.

搭配伺服马达一览表 Suitable motor brand

品牌 Brand	马达记号 Mark	刹车有无 Brake	马达容量 Motor capacity	电源电压 AC-Voltage	伺服马达型号 Servo motor model	驱动器型号 Driver Model
三菱 Mitsubishi	M	无刹车(水平式样) No brake (horizontal type)	200	220	HG-KR73	MR-J4-70A
松下 Panasonic	P	无刹车(水平式样) No brake (horizontal type)	200	220	MHMD082G1U	MBDHT3520
台达 Delta	T	无刹车(水平式样) No brake (horizontal type)	200	220	ECMA-C20807ES	ASD-B20721-B



电机外置左侧/电机外置右侧  
Motor external left side / Motor external right side

ML 电机外置左侧 Motor external left side

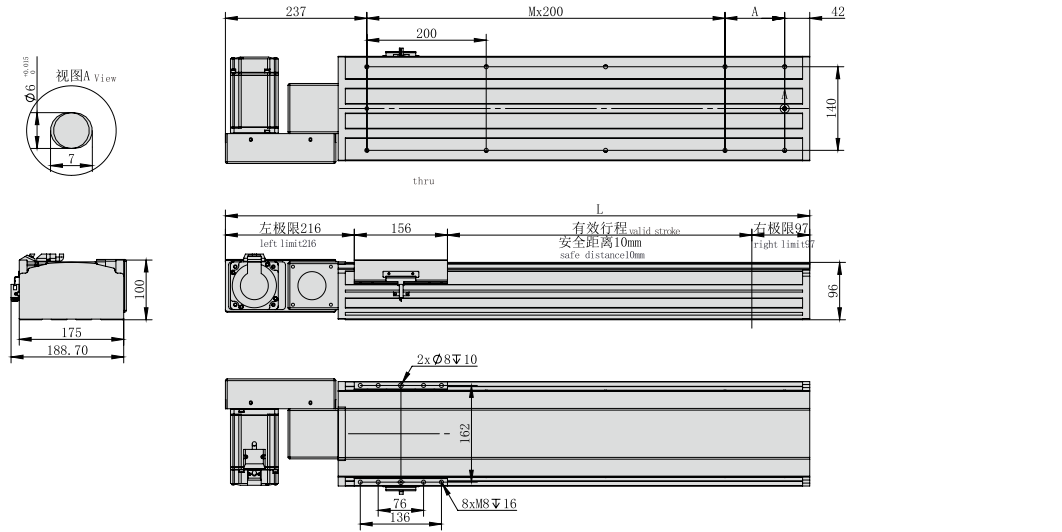

单位:Unit: mm

\*不含电机重量。\*Motor weight not included.

有效行程 Stroke	150	250	350	450	550	650	750	850	950	1050	1150	1250	1350	1450	1550	1650	1750	1850	1950	2050	2150	2250	2350	2450	2550	2650	2750	2850	2950	3050
L	629	729	829	929	1029	1129	1229	1329	1429	1529	1629	1729	1829	1929	2029	2129	2229	2329	2429	2529	2629	2729	2829	2929	3029	3129	3229	3329	3429	3529
A	150	50	150	50	150	50	150	50	150	50	150	50	150	50	150	50	150	50	150	50	150	50	150	50	150	50	150	50	150	50
N	6	8	8	10	10	12	12	14	14	16	16	18	18	20	20	22	22	24	24	26	26	28	28	30	30	32	32	34	34	36
M	1	2	2	3	3	4	4	5	5	6	6	7	7	8	8	9	9	10	10	11	11	12	12	13	13	14	14	15	15	16
KG	13	14	15	16	17	18	19	20	21	22	23	24	25	26	27	28	29	30	31	32	33	34	35	36	37	38	39	40	41	42

如有超长行程及定制需求, 请咨询我司业务。If you have extra long trip and custom requirements, please consult our business.

电机外置左下/电机外置左上  
Motor external lower left / Motor external upper left

LP 电机外置左下 Motor external lower left

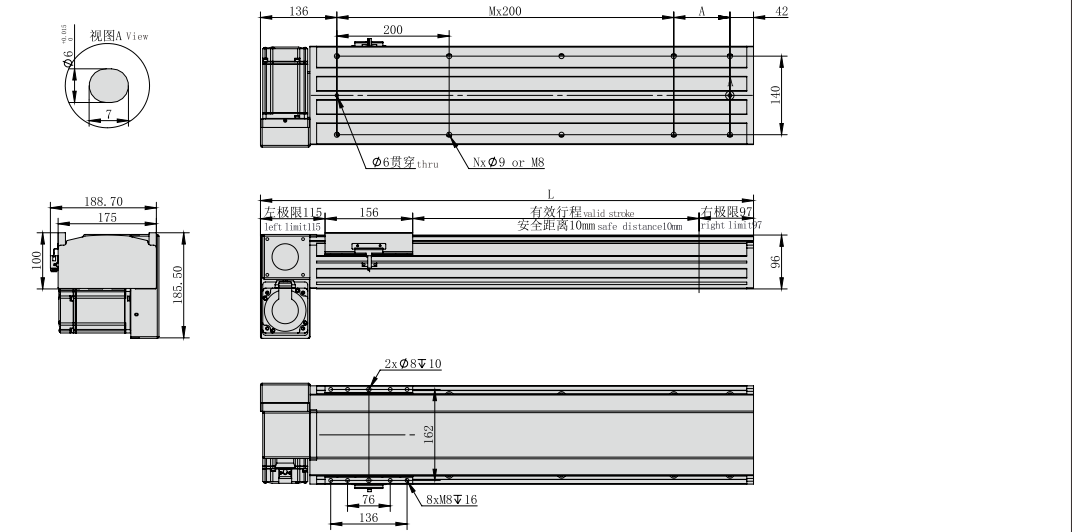

单位:Unit: mm

\*不含电机重量。\*Motor weight not included.

有效行程 Stroke	150	250	350	450	550	650	750	850	950	1050	1150	1250	1350	1450	1550	1650	1750	1850	1950	2050	2150	2250	2350	2450	2550	2650	2750	2850	2950	3050
L	528	628	728	828	928	1028	1128	1228	1328	1428	1528	1628	1728	1828	1928	2028	2128	2228	2328	2428	2528	2628	2728	2828	2928	3028	3128	3228	3328	3428
A	150	50	150	50	150	50	150	50	150	50	150	50	150	50	150	50	150	50	150	50	150	50	150	50	150	50	150	50	150	50
N	6	8	8	10	10	12	12	14	14	16	16	18	18	20	20	22	22	24	24	26	26	28	28	30	30	32	32	34	34	36
M	1	2	2	3	3	4	4	5	5	6	6	7	7	8	8	9	9	10	10	11	11	12	12	13	13	14	14	15	15	16
KG	13	14	15	16	17	18	19	20	21	22	23	24	25	26	27	28	29	30	31	32	33	34	35	36	37	38	39	40	41	42

如有超长行程及定制需求, 请咨询我司业务。If you have extra long trip and custom requirements, please consult our business.

MR 电机外置右侧 Motor external right side

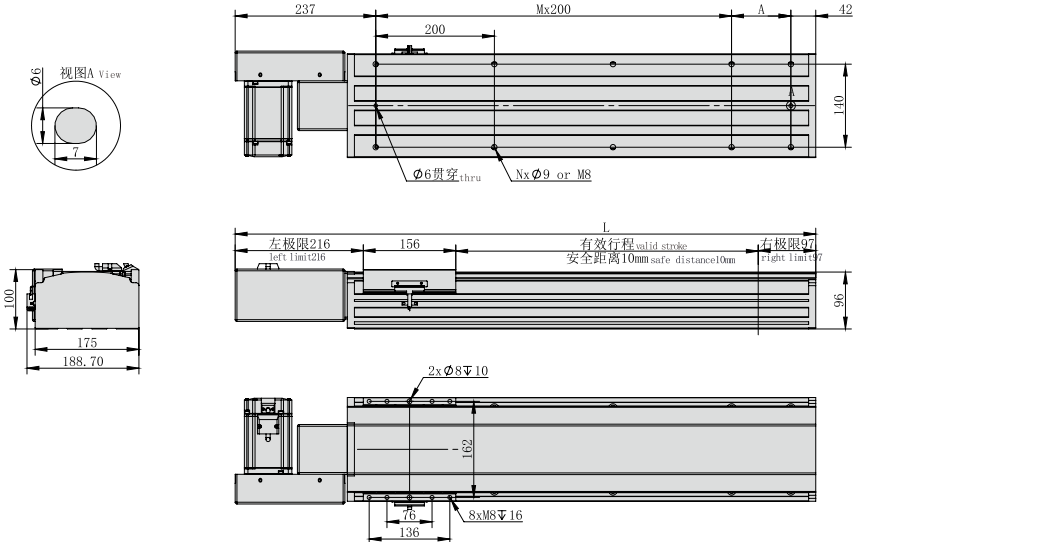

单位:Unit: mm

\*不含电机重量。\*Motor weight not included.

有效行程 Stroke	150	250	350	450	550	650	750	850	950	1050	1150	1250	1350	1450	1550	1650	1750	1850	1950	2050	2150	2250	2350	2450	2550	2650	2750	2850	2950	3050
L	629	729	829	929	1029	1129	1229	1329	1429	1529	1629	1729	1829	1929	2029	2129	2229	2329	2429	2529	2629	2729	2829	2929	3029	3129	3229	3329	3429	3529
A	150	50	150	50	150	50	150	50	150	50	150	50	150	50	150	50	150	50	150	50	150	50	150	50	150	50	150	50	150	50
N	6	8	8	10	10	12	12	14	14	16	16	18	18	20	20	22	22	24	24	26	26	28	28	30	30	32	32	34	34	36
M	1	2	2	3	3	4	4	5	5	6	6	7	7	8	8	9	9	10	10	11	11	12	12	13	13	14	14	15	15	16
KG	13	14	15	16	17	18	19	20	21	22	23	24	25	26	27	28	29	30	31	32	33	34	35	36	37	38	39	40	41	42

如有超长行程及定制需求, 请咨询我司业务。If you have extra long trip and custom requirements, please consult our business.

LU 电机外置左上 Motor external upper left

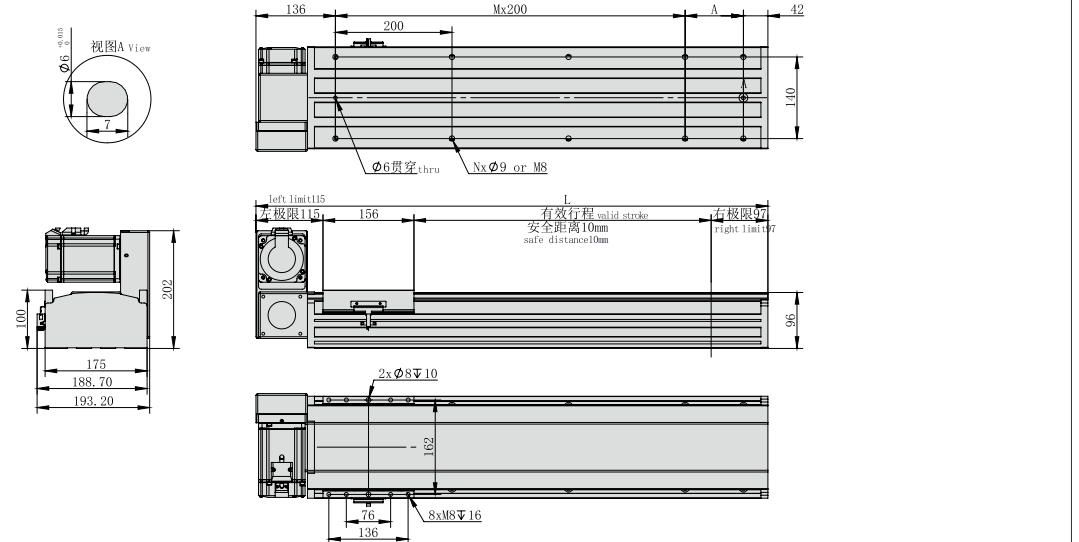

单位:Unit: mm

\*不含电机重量。\*Motor weight not included.

有效行程 Stroke	150	250	350	450	550	650	750	850	950	1050	1150	1250	1350	1450	1550	1650	1750	1850	1950	2050	2150	2250	2350	2450	2550	2650	2750	2850	2950	3050
L	528	628	728	828	928	1028	1128	1228	1328	1428	1528	1628	1728	1828	1928	2028	2128	2228	2328	2428	2528	2628	2728	2828	2928	3028	3128	3228	3328	3428
A	150	50	150	50	150	50	150	50	150	50	150	50	150	50	150	50	150	50	150	50	150	50	150	50	150	50	150	50	150	50
N	6	8	8	10	10	12	12	14	14	16	16	18	18	20	20	22	22	24	24	26	26	28	28	30	30	32	32	34	34	36
M	1	2	2	3	3	4	4	5	5	6	6	7	7	8	8	9	9	10	10	11	11	12	12	13	13	14	14	15	15	16
KG	13	14	15	16	17	18	19	20	21	22	23	24	25	26	27	28	29	30	31	32	33	34	35	36	37	38	39	40	41	42

如有超长行程及定制需求, 请咨询我司业务。If you have extra long trip and custom requirements, please consult our business.



电机外置右下/电机外置右上  
Motor external lower right / Motor external upper right

RP 电机外置右下 Motor external lower right

单位:Unit: mm

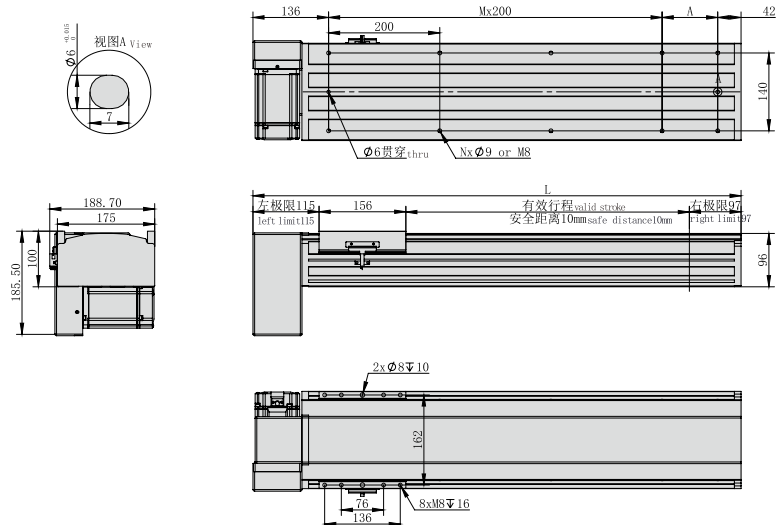

\*不含电机重量。\*Motor weight not included.

有效行程 Stroke	150	250	350	450	550	650	750	850	950	1050	1150	1250	1350	1450	1550	1650	1750	1850	1950	2050	2150	2250	2350	2450	2550	2650	2750	2850	2950	3050
L	528	628	728	828	928	1028	1128	1228	1328	1428	1528	1628	1728	1828	1928	2028	2128	2228	2328	2428	2528	2628	2728	2828	2928	3028	3128	3228	3328	3428
A	150	50	150	50	150	50	150	50	150	50	150	50	150	50	150	50	150	50	150	50	150	50	150	50	150	50	150	50	150	50
N	6	8	8	10	10	12	12	14	14	16	16	18	18	20	20	22	22	24	24	26	26	28	28	30	30	32	32	34	34	36
M	1	2	2	3	3	4	4	5	5	6	6	7	7	8	8	9	9	10	10	11	11	12	12	13	13	14	14	15	15	16
KG	13	14	15	16	17	18	19	20	21	22	23	24	25	26	27	28	29	30	31	32	33	34	35	36	37	38	39	40	41	42

如有超长行程及定制需求,请咨询我司业务。If you have extra long trip and custom requirements, please consult our business.

RU 电机外置右上 Motor external upper right

单位:Unit: mm

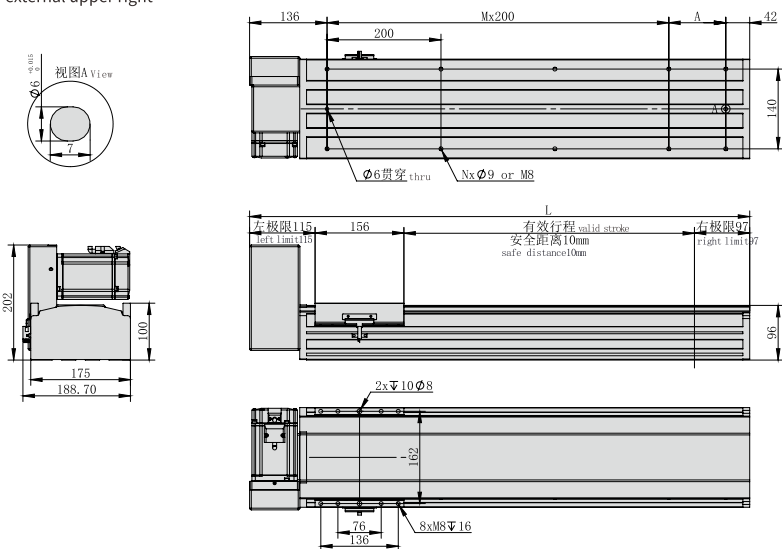

\*不含电机重量。\*Motor weight not included.

有效行程 Stroke	150	250	350	450	550	650	750	850	950	1050	1150	1250	1350	1450	1550	1650	1750	1850	1950	2050	2150	2250	2350	2450	2550	2650	2750	2850	2950	3050
L	528	628	728	828	928	1028	1128	1228	1328	1428	1528	1628	1728	1828	1928	2028	2128	2228	2328	2428	2528	2628	2728	2828	2928	3028	3128	3228	3328	3428
A	150	50	150	50	150	50	150	50	150	50	150	50	150	50	150	50	150	50	150	50	150	50	150	50	150	50	150	50	150	50
N	6	8	8	10	10	12	12	14	14	16	16	18	18	20	20	22	22	24	24	26	26	28	28	30	30	32	32	34	34	36
M	1	2	2	3	3	4	4	5	5	6	6	7	7	8	8	9	9	10	10	11	11	12	12	13	13	14	14	15	15	16
KG	13	14	15	16	17	18	19	20	21	22	23	24	25	26	27	28	29	30	31	32	33	34	35	36	37	38	39	40	41	42

如有超长行程及定制需求,请咨询我司业务。If you have extra long trip and custom requirements, please consult our business.

MEMO

- HNR
- HCR
- HNB
- HCB
- HNT
- XYZ
- ONB
- OCB
- GCR
- GCB
- GCBS
- GCRS
- ESR
- EMR
- EHR
- KSR
- LNP
- DDR

参考资料  
Reference  
data





重复精度  
Repeat Accuracy  
±0.04  
mm

此图仅供参考, 出货规格详见尺寸图面  
This picture for reference only, specs details according with the drawing.

最大行程  
Max stroke 3050mm

最高速度  
Max speed 7000mm/s

马达容量  
Motor output 750W

直线滑轨  
Linear guide 23X18-2支

型号表达方式 Ordering method

TPA-HNB-202D-140-L3050-MR-Y-P75-N3-F

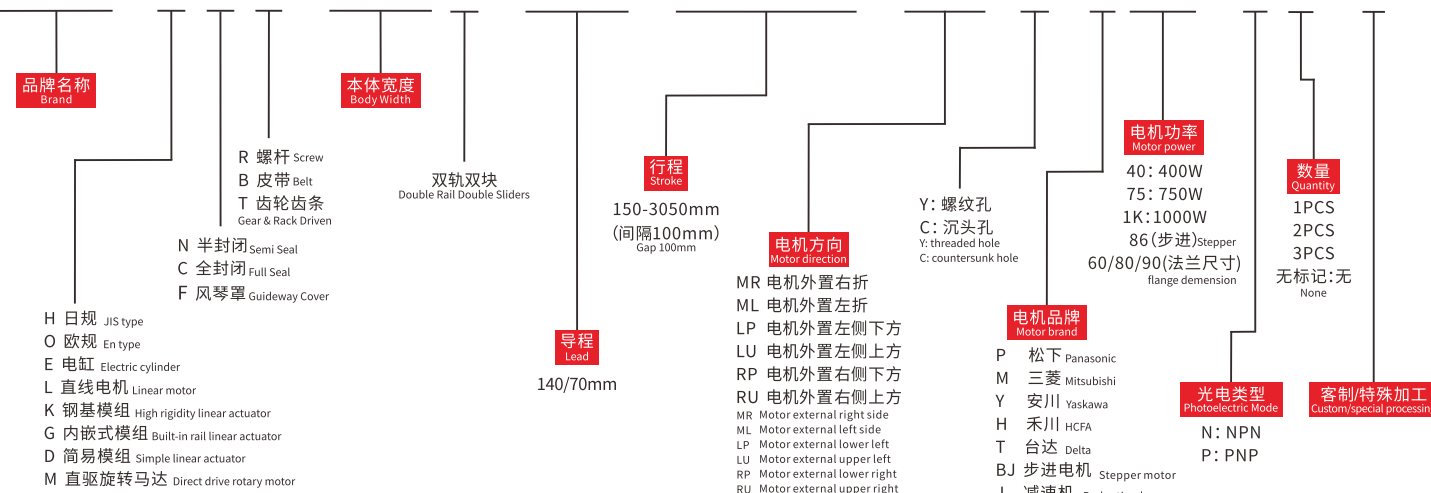

产品性能参数如下 Product performance parameters are as follows

电机功率 (W) Motor power (W)	750	
重复定位精度 (mm) Repeated positioning accuracy (mm)	±0.04	
减速比 (mm) Reduction ratio	1:1	1:2
规格 导程 (mm) Lead (mm)	140	70
最高速度 (mm/s) Maximum speed (mm/s)	7000	
电机额定转速 (RPM) Rated speed of motor (RPM)	3000	
最大可搬重量 Maximum Payload	40	80
标准行程 (mm) Stroke pitch (mm)	150~3050mm/100 间隔100 mm Pitch	
部品 基座材质 Material of base	硬质挤压铝材A1 Hard extruded aluminum A1	
使用环境 Operating environment	0~40°C, 85%RH (无凝结) No condensation	

注1: 使用非上述功率电机时请依据实际参数推算。  
Note 1: When using a motor with a power other than the above, please calculate according to the actual parameters.

注2: 最高速度因行程和负载而异, 当螺杆菌细长比大于1:50时, 可能会因螺杆菌临界速度产生共振和抖动, 应适当下调运行速度, 一般螺杆菌每增长100mm, 速度应下调10~15%。  
Note 2: The maximum speed varies with stroke and load. When the screw slenderness ratio is greater than 1:50, resonance and jitter may occur due to the critical speed of the screw, so the running speed should be reduced appropriately. Generally, the speed should be reduced by 10~15% for every 100mm increase of the screw.

容许负载力矩表 N.m Allowable overhang

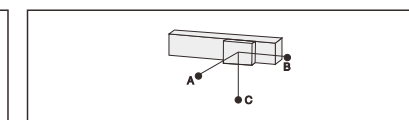
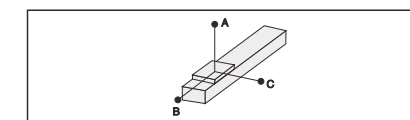

(单位Unit:mm)				(单位Unit:mm)			
水平安装 Horizontal installation	A	B	C	侧面安装 Side mounting	A	B	C
45kg	1588	600	349	负载 Load	40kg	500	685
65kg	1052	328	285		60kg	315	430
85kg	768	281	206		85kg	206	281

传感器连接图<原点及端点> Sensor layout

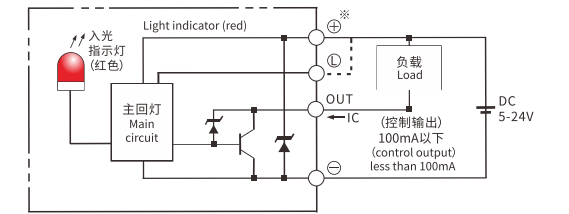

- HNR
- HCR
- HNB
- HCB
- HNT
- XYZ
- ONB
- OCB
- GCR
- GCB
- GCBS
- GCRS
- ESR
- EMR
- EHR
- KSR
- LNP
- DDR
- 参考资料  
Reference data

静态容许负载惯量 Static loading moment

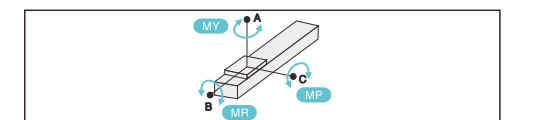

(单位Unit:N.m)	
MY	2052
MP	2052
MR	1810

\*力矩表所表示的数据, 代表重心。  
The torque value in the chart indicate the center of gravity.  
\*符合型录规范的正常试用下, 保证寿命为10000公里。  
Operation life is 10,000km when the product is using under the specified conditions.  
\*倒吊使用无法套用标准规范, 如有需求请咨询我司业务。  
The standard specification cannot be applied to the use of inverted crane. Please consult our business if necessary.

搭配伺服马达一览表 Suitable motor brand

品牌 Brand	马达记号 Mark	刹车有无 Brake	马达容量 Motor capacity	电源电压 AC-Voltage	伺服马达型号 Servo motor model	驱动器型号 Driver Model
三菱 Mitsubishi	M	无刹车(水平式样) No brake (horizontal type)	200	220	HG-KR73	MR-J4-70A
松下 Panasonic	P	无刹车(水平式样) No brake (horizontal type)	200	220	MHMD082G1U	MBDHT3520
台达 Delta	T	无刹车(水平式样) No brake (horizontal type)	200	220	ECMA-C20807ES	ASD-B20721-B



电机外置左侧/电机外置右侧  
Motor external left side / Motor external right side

ML 电机外置左侧 Motor external left side

单位:Unit: mm

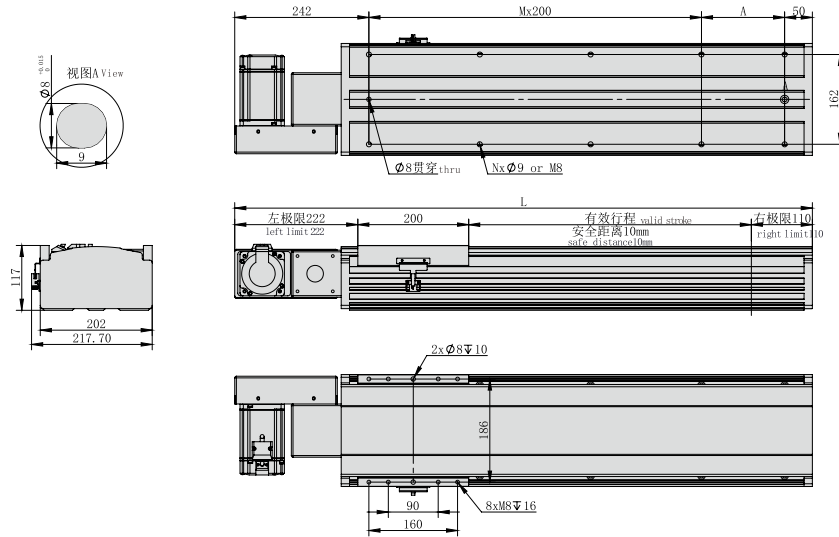

\*不含电机重量。\*Motor weight not included.

有效行程 Stroke	150	250	350	450	550	650	750	850	950	1050	1150	1250	1350	1450	1550	1650	1750	1850	1950	2050	2150	2250	2350	2450	2550	2650	2750	2850	2950	3050
L	692	792	892	992	1092	1192	1292	1392	1492	1592	1692	1792	1892	1992	2092	2192	2292	2392	2492	2592	2692	2792	2892	2992	3092	3192	3292	3392	3492	3592
A	200	100	200	100	200	100	200	100	200	100	200	100	200	100	200	100	200	100	200	100	200	100	200	100	200	100	200	100	200	100
N	6	8	8	10	10	12	12	14	14	16	16	18	18	20	20	22	22	24	24	26	26	28	28	30	30	32	32	34	34	36
M	1	2	2	3	3	4	4	5	5	6	6	7	7	8	8	9	9	10	10	11	11	12	12	13	13	14	14	15	15	16
KG	21	22.5	24	25.5	27	28.5	30	31.5	33	34.5	36	37.5	39	40.5	42	43.5	45	46.5	48	49.5	51	52.5	54	55.5	57	58.5	60	61.5	63	64.5

如有超长行程及定制需求, 请咨询我司业务。 If you have extra long trip and custom requirements, please consult our business.

电机外置左下/电机外置左上  
Motor external lower left / Motor external upper left

LP 电机外置左下 Motor external lower left

单位:Unit: mm

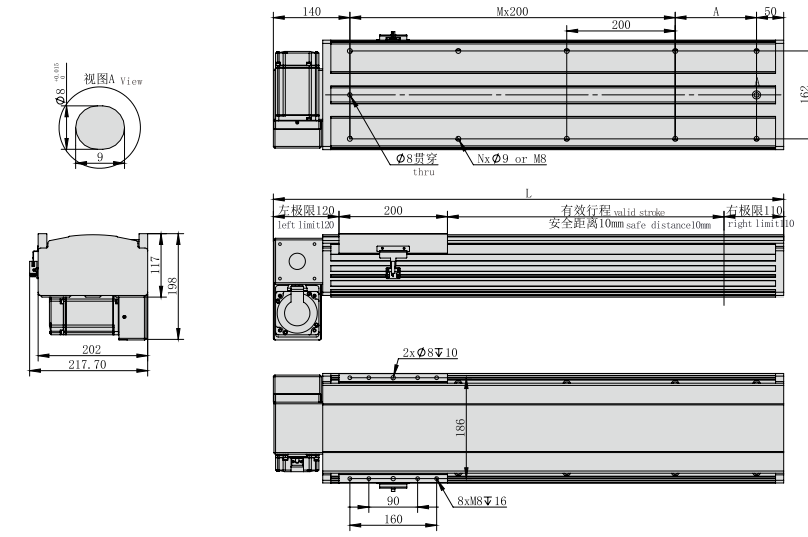

\*不含电机重量。\*Motor weight not included.

有效行程 Stroke	150	250	350	450	550	650	750	850	950	1050	1150	1250	1350	1450	1550	1650	1750	1850	1950	2050	2150	2250	2350	2450	2550	2650	2750	2850	2950	3050
L	590	690	790	890	990	1090	1190	1290	1390	1490	1590	1690	1790	1890	1990	2090	2190	2290	2390	2490	2590	2690	2790	2890	2990	3090	3190	3290	3390	3490
A	200	100	200	100	200	100	200	100	200	100	200	100	200	100	200	100	200	100	200	100	200	100	200	100	200	100	200	100	200	100
N	6	8	8	10	10	12	12	14	14	16	16	18	18	20	20	22	22	24	24	26	26	28	28	30	30	32	32	34	34	36
M	1	2	2	3	3	4	4	5	5	6	6	7	7	8	8	9	9	10	10	11	11	12	12	13	13	14	14	15	15	16
KG	21	22.5	24	25.5	27	28.5	30	31.5	33	34.5	36	37.5	39	40.5	42	43.5	45	46.5	48	49.5	51	52.5	54	55.5	57	58.5	60	61.5	63	64.5

如有超长行程及定制需求, 请咨询我司业务。 If you have extra long trip and custom requirements, please consult our business.

MR 电机外置右侧 Motor external right side

单位:Unit: mm

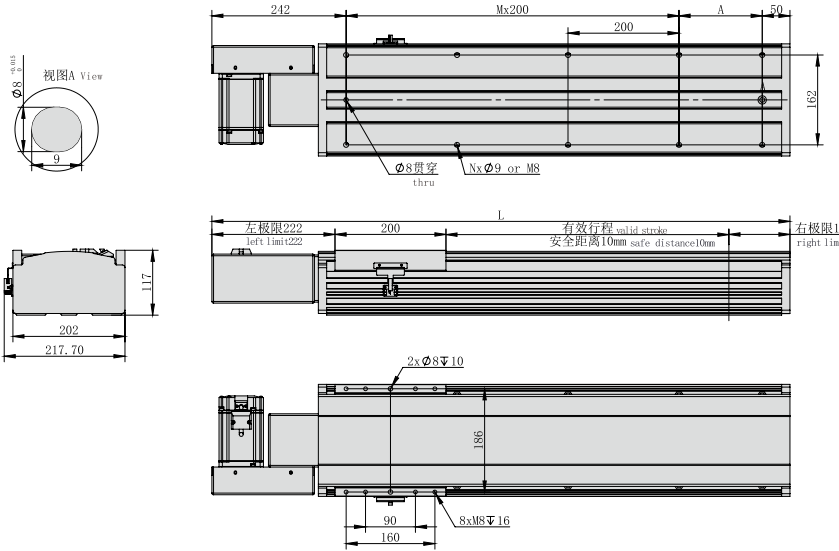

\*不含电机重量。\*Motor weight not included.

有效行程 Stroke	150	250	350	450	550	650	750	850	950	1050	1150	1250	1350	1450	1550	1650	1750	1850	1950	2050	2150	2250	2350	2450	2550	2650	2750	2850	2950	3050
L	692	792	892	992	1092	1192	1292	1392	1492	1592	1692	1792	1892	1992	2092	2192	2292	2392	2492	2592	2692	2792	2892	2992	3092	3192	3292	3392	3492	3592
A	200	100	200	100	200	100	200	100	200	100	200	100	200	100	200	100	200	100	200	100	200	100	200	100	200	100	200	100	200	100
N	6	8	8	10	10	12	12	14	14	16	16	18	18	20	20	22	22	24	24	26	26	28	28	30	30	32	32	34	34	36
M	1	2	2	3	3	4	4	5	5	6	6	7	7	8	8	9	9	10	10	11	11	12	12	13	13	14	14	15	15	16
KG	21	22.5	24	25.5	27	28.5	30	31.5	33	34.5	36	37.5	39	40.5	42	43.5	45	46.5	48	49.5	51	52.5	54	55.5	57	58.5	60	61.5	63	64.5

如有超长行程及定制需求, 请咨询我司业务。 If you have extra long trip and custom requirements, please consult our business.

LU 电机外置左上 Motor external upper left

单位:Unit: mm

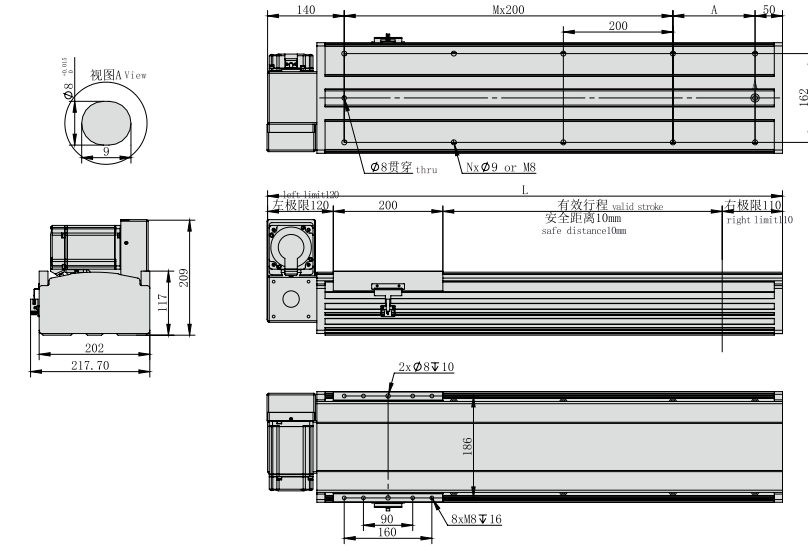

\*不含电机重量。\*Motor weight not included.

有效行程 Stroke	150	250	350	450	550	650	750	850	950	1050	1150	1250	1350	1450	1550	1650	1750	1850	1950	2050	2150	2250	2350	2450	2550	2650	2750	2850	2950	3050
L	590	690	790	890	990	1090	1190	1290	1390	1490	1590	1690	1790	1890	1990	2090	2190	2290	2390	2490	2590	2690	2790	2890	2990	3090	3190	3290	3390	3490
A	200	100	200	100	200	100	200	100	200	100	200	100	200	100	200	100	200	100	200	100	200	100	200	100	200	100	200	100	200	100
N	6	8	8	10	10	12	12	14	14	16	16	18	18	20	20	22	22	24	24	26	26	28	28	30	30	32	32	34	34	36
M	1	2	2	3	3	4	4	5	5	6	6	7	7	8	8	9	9	10	10	11	11	12	12	13	13	14	14	15	15	16
KG	21	22.5	24	25.5	27	28.5	30	31.5	33	34.5	36	37.5	39	40.5	42	43.5	45	46.5	48	49.5	51	52.5	54	55.5	57	58.5	60	61.5	63	64.5

如有超长行程及定制需求, 请咨询我司业务。 If you have extra long trip and custom requirements, please consult our business.

- HNR
- HCR
- HNB
- HCB
- HNT
- XYZ
- ONB
- OCB
- GCR
- GCB
- GCBS
- GCRS
- ESR
- EMR
- EHR
- KSR
- LNP
- DDR

参考资料  
Reference data



电机外置右下/电机外置右上  
Motor external lower right / Motor external upper right

RP 电机外置右下 Motor external lower right

单位:Unit: mm

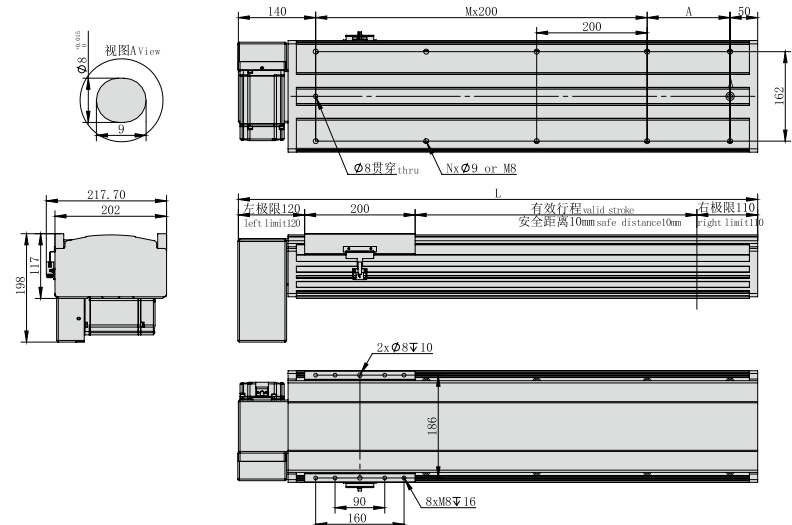

\*不含电机重量。\*Motor weight not included.

有效行程 Stroke	150	250	350	450	550	650	750	850	950	1050	1150	1250	1350	1450	1550	1650	1750	1850	1950	2050	2150	2250	2350	2450	2550	2650	2750	2850	2950	3050
L	590	690	790	890	990	1090	1190	1290	1390	1490	1590	1690	1790	1890	1990	2090	2190	2290	2390	2490	2590	2690	2790	2890	2990	3090	3190	3290	3390	3490
A	200	100	200	100	200	100	200	100	200	100	200	100	200	100	200	100	200	100	200	100	200	100	200	100	200	100	200	100	200	100
N	6	8	8	10	10	12	12	14	14	16	16	18	18	20	20	22	22	24	24	26	26	28	28	30	30	32	32	34	34	36
M	1	2	2	3	3	4	4	5	5	6	6	7	7	8	8	9	9	10	10	11	11	12	12	13	13	14	14	15	15	16
KG	21	22.5	24	25.5	27	28.5	30	31.5	33	34.5	36	37.5	39	40.5	42	43.5	45	46.5	48	49.5	51	52.5	54	55.5	57	58.5	60	61.5	63	64.5

如有超长行程及定制需求,请咨询我司业务。If you have extra long trip and custom requirements, please consult our business.

RU 电机外置右上 Motor external upper right

单位:Unit: mm

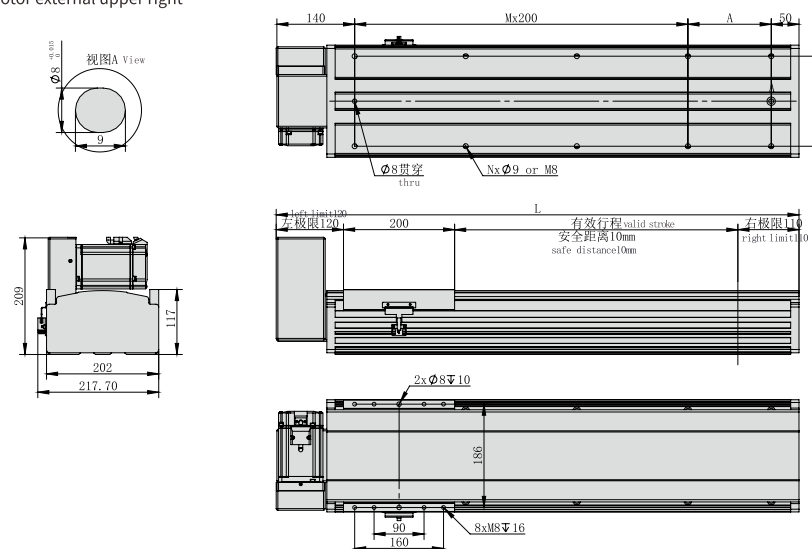

\*不含电机重量。\*Motor weight not included.

有效行程 Stroke	150	250	350	450	550	650	750	850	950	1050	1150	1250	1350	1450	1550	1650	1750	1850	1950	2050	2150	2250	2350	2450	2550	2650	2750	2850	2950	3050
L	590	690	790	890	990	1090	1190	1290	1390	1490	1590	1690	1790	1890	1990	2090	2190	2290	2390	2490	2590	2690	2790	2890	2990	3090	3190	3290	3390	3490
A	200	100	200	100	200	100	200	100	200	100	200	100	200	100	200	100	200	100	200	100	200	100	200	100	200	100	200	100	200	100
N	6	8	8	10	10	12	12	14	14	16	16	18	18	20	20	22	22	24	24	26	26	28	28	30	30	32	32	34	34	36
M	1	2	2	3	3	4	4	5	5	6	6	7	7	8	8	9	9	10	10	11	11	12	12	13	13	14	14	15	15	16
KG	21	22.5	24	25.5	27	28.5	30	31.5	33	34.5	36	37.5	39	40.5	42	43.5	45	46.5	48	49.5	51	52.5	54	55.5	57	58.5	60	61.5	63	64.5

如有超长行程及定制需求,请咨询我司业务。If you have extra long trip and custom requirements, please consult our business.

MEMO

- HNR
- HCR
- HNB
- HCB
- HNT
- XYZ
- ONB
- OCB
- GCR
- GCB
- GCBS
- GCRS
- ESR
- EMR
- EHR
- KSR
- LNP
- DDR

参考资料  
Reference data



重复精度  
Repeat Accuracy  
±0.04  
mm

此图仅供参考, 出货规格详见尺寸图面  
This picture for reference only, specs details according with the drawing.

最大行程  
Max stroke 3050mm

最高速度  
Max speed 8800mm/s

马达容量  
Motor output 1000W

直线滑轨  
Linear guide 23X22-2支

型号表达方式 Ordering method

TPA-HNB-220D-176-L3050-MR-Y-P1K-N3-F

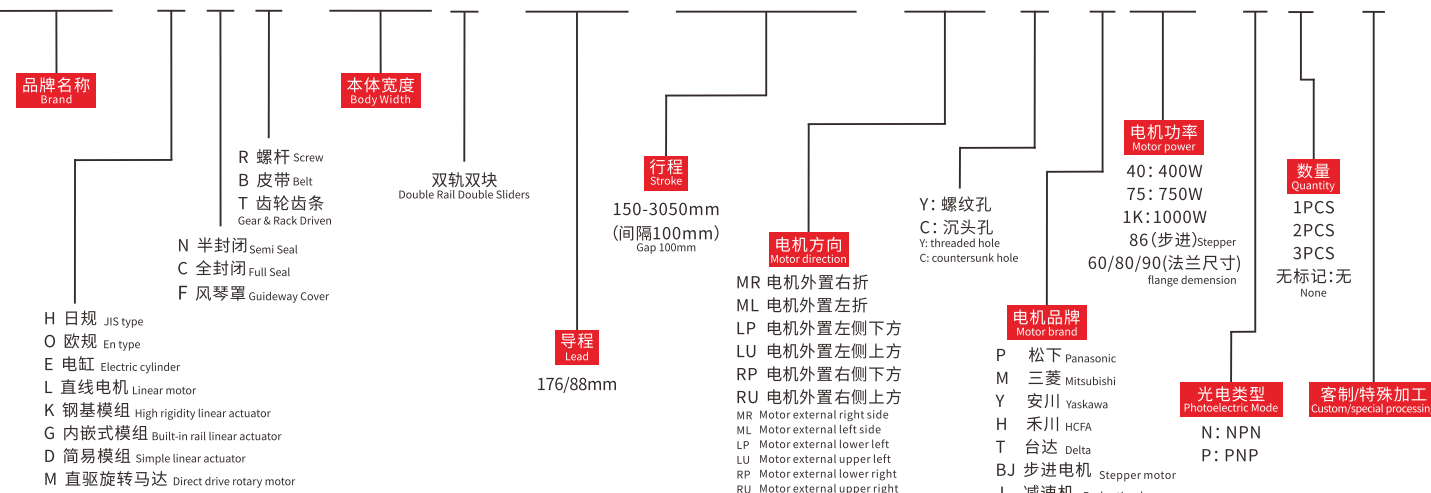

产品性能参数如下 Product performance parameters are as follows

规格 Spec	电机功率 (W) Motor power (W)	1000	
	重复定位精度 (mm) Repeated positioning accuracy (mm)	±0.04	
	减速比 (mm) Reduction ratio	1:1	1:2
	导程 (mm) Lead (mm)	176	88
	最高速度 (mm/s) Maximum speed (mm/s)	8800	
	电机额定转速 (RPM) Rated speed of motor (RPM)	3000	
最大可搬重量 Maximum Payload	50	100	
	标准行程 (mm) Stroke pitch (mm)	150~3050mm/100 间隔100 mm Pitch	
部品 Parts	底座材质 Material of base	硬质挤压铝材A1 Hard extruded aluminum A1	
	使用环境 Operating environment	0~40°C, 85%RH (无凝结) No condensation	

注1: 使用非上述功率电机时请依据实际参数推算。  
Note 1: When using a motor with a power other than the above, please calculate according to the actual parameters.

注2: 最高速度因行程和负载而异, 当螺杆细长比大于1:50时, 可能会因螺杆临界速度产生共振和抖动, 应适当下调运行速度, 一般螺杆每增长100mm, 速度应下调10~15%。  
Note 2: The maximum speed varies with stroke and load. When the screw slenderness ratio is greater than 1:50, resonance and jitter may occur due to the critical speed of the screw, so the running speed should be reduced appropriately. Generally, the speed should be reduced by 10~15% for every 100mm increase of the screw.

容许负载力矩表 N.m Allowable overhang

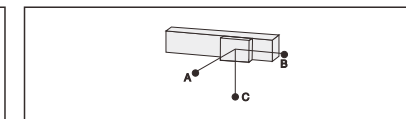
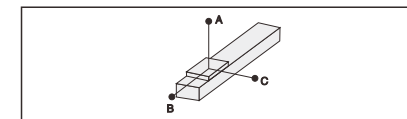

(单位Unit:mm)

水平安装 Horizontal installation	A	B	C
45kg	3444	1015	1358
65kg	2460	725	970
85kg	1800	550	740

(单位Unit:mm)

侧面安装 Side mounting	A	B	C
45kg	1410	925	3435
65kg	1010	664	2455
85kg	770	500	1886

传感器连接图<原点及端点> Sensor layout

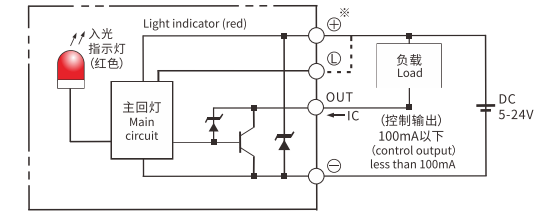

- HNR
- HCR
- HNB
- HCB
- HNT
- XYZ
- ONB
- OCB
- GCR
- GCB
- GCBS
- GCRS
- ESR
- EMR
- EHR
- KSR
- LNP
- DDR

参考资料  
Reference data

静态容许负载惯量 Static loading moment

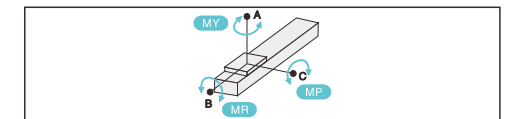

(单位Unit:N.m)

MY	2052
MP	2052
MR	1810

\*力矩表所表示的数据, 代表重心。  
The torque value in the chart indicate the center of gravity.  
\*符合型录规范的正常试用下, 保证寿命为10000公里。  
Operation life is 10,000km when the product is using under the specified conditions.  
\*倒吊使用无法套用标准规范, 如有需求请咨询我司业务。  
The standard specification cannot be applied to the use of inverted crane. Please consult our business if necessary.

搭配伺服马达一览表 Suitable motor brand

品牌 Brand	马达记号 Mark	刹车有无 Brake	马达容量 Motor capacity	电源电压 AC-Voltage	伺服马达型号 Servo motor model	驱动器型号 Driver Model
三菱 Mitsubishi	M	无刹车(水平式样) No brake (horizontal type)	200	220	HG-KR73	MR-J4-70A
松下 Panasonic	P	无刹车(水平式样) No brake (horizontal type)	200	220	MHMD082G1U	MBDHT3520
台达 Delta	T	无刹车(水平式样) No brake (horizontal type)	200	220	ECMA-C20807ES	ASD-B20721-B



电机外置左侧/电机外置右侧  
Motor external left side / Motor external right side

ML 电机外置左侧 Motor external left side

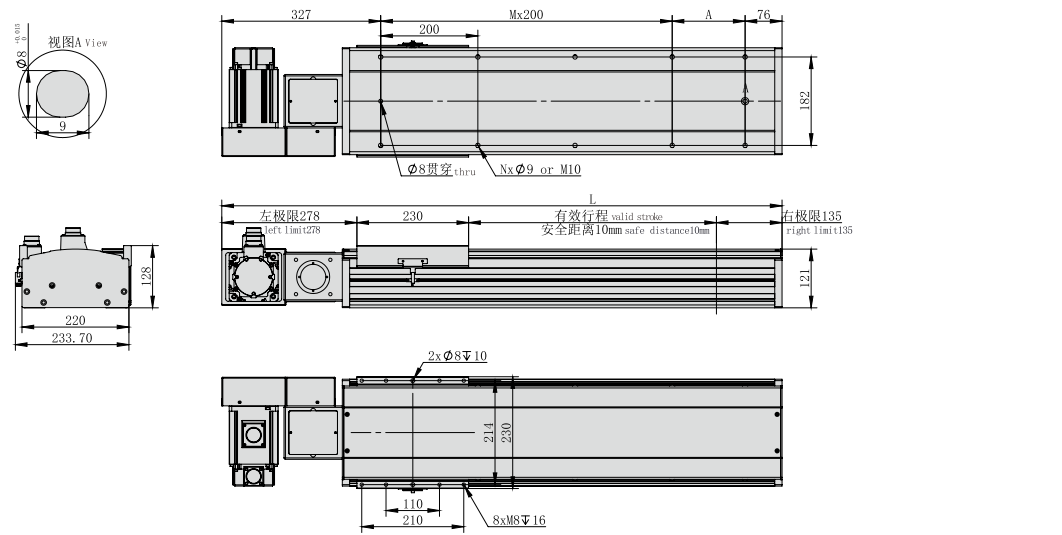

\*不含电机重量。\*Motor weight not included.

有效行程 Stroke	150	250	350	450	550	650	750	850	950	1050	1150	1250	1350	1450	1550	1650	1750	1850	1950	2050	2150	2250	2350	2450	2550	2650	2750	2850	2950	3050
L	803	903	1003	1103	1203	1303	1403	1503	1603	1703	1803	1903	2003	2103	2203	2303	2403	2503	2603	2703	2803	2903	3003	3103	3203	3303	3403	3503	3603	3703
A	200	100	200	100	200	100	200	100	200	100	200	100	200	100	200	100	200	100	200	100	200	100	200	100	200	100	200	100	200	100
N	6	8	8	10	10	12	12	14	14	16	16	18	18	20	20	22	22	24	24	26	26	28	28	30	30	32	32	34	34	36
M	2	2	3	3	4	4	5	5	6	6	7	7	8	8	9	9	10	10	11	11	12	12	13	13	14	14	15	15	16	16
KG	26.5	28	29.5	31	32.5	34	35.5	37	38.5	40	41.5	43	44.5	46	47.5	49	50.5	52	53.5	55	56.5	58	59.5	61	62.5	64	65.5	67	68.5	70

如有超长行程及定制需求,请咨询我司业务。If you have extra long trip and custom requirements, please consult our business.

MR 电机外置右侧 Motor external right side

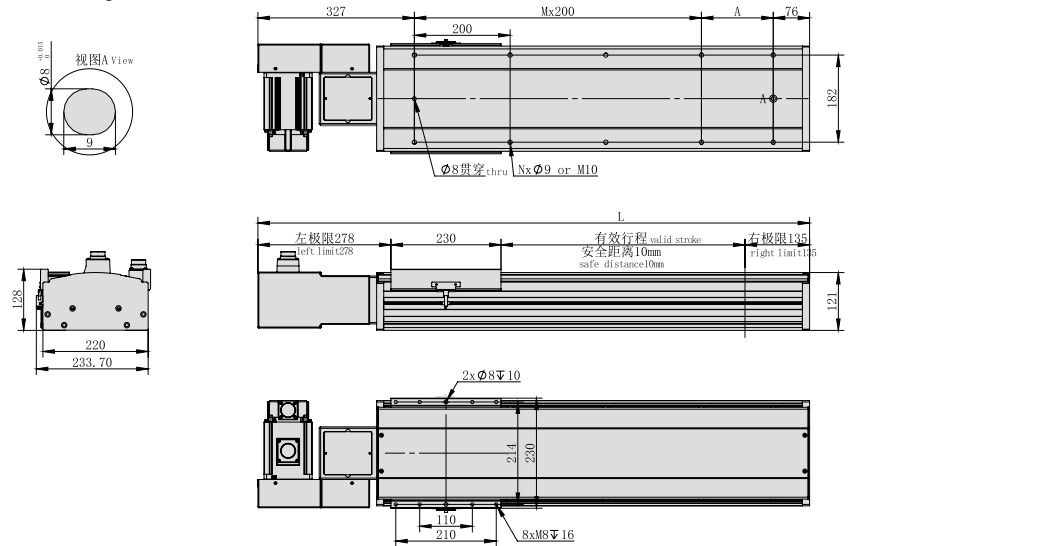

\*不含电机重量。\*Motor weight not included.

有效行程 Stroke	150	250	350	450	550	650	750	850	950	1050	1150	1250	1350	1450	1550	1650	1750	1850	1950	2050	2150	2250	2350	2450	2550	2650	2750	2850	2950	3050
L	803	903	1003	1103	1203	1303	1403	1503	1603	1703	1803	1903	2003	2103	2203	2303	2403	2503	2603	2703	2803	2903	3003	3103	3203	3303	3403	3503	3603	3703
A	200	100	200	100	200	100	200	100	200	100	200	100	200	100	200	100	200	100	200	100	200	100	200	100	200	100	200	100	200	100
N	6	8	8	10	10	12	12	14	14	16	16	18	18	20	20	22	22	24	24	26	26	28	28	30	30	32	32	34	34	36
M	2	2	3	3	4	4	5	5	6	6	7	7	8	8	9	9	10	10	11	11	12	12	13	13	14	14	15	15	16	16
KG	26.5	28	29.5	31	32.5	34	35.5	37	38.5	40	41.5	43	44.5	46	47.5	49	50.5	52	53.5	55	56.5	58	59.5	61	62.5	64	65.5	67	68.5	70

如有超长行程及定制需求,请咨询我司业务。If you have extra long trip and custom requirements, please consult our business.

电机外置左下/电机外置左上  
Motor external lower left / Motor external upper left

LP 电机外置左下 Motor external lower left

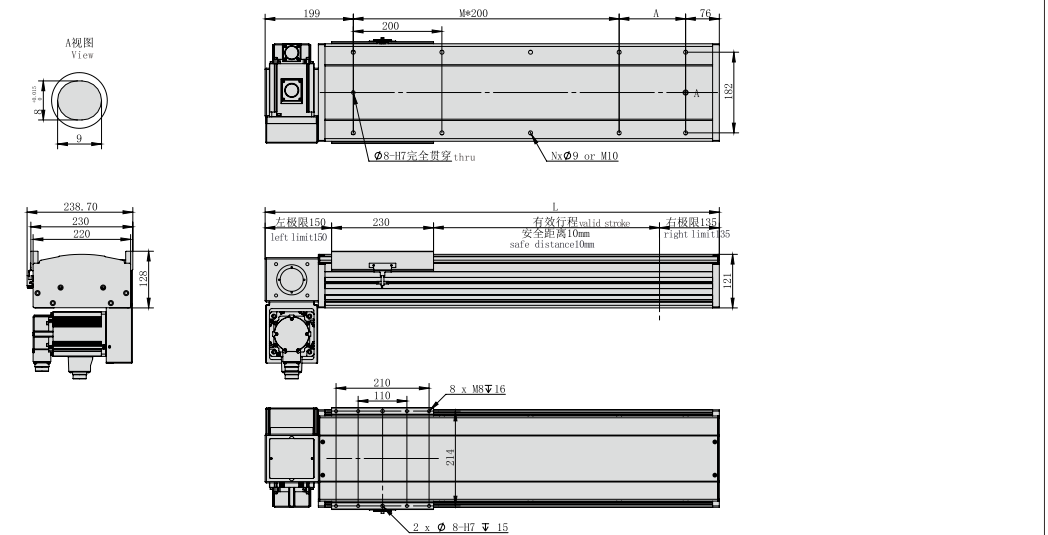

\*不含电机重量。\*Motor weight not included.

有效行程 Stroke	150	250	350	450	550	650	750	850	950	1050	1150	1250	1350	1450	1550	1650	1750	1850	1950	2050	2150	2250	2350	2450	2550	2650	2750	2850	2950	3050
L	675	775	875	975	1075	1175	1275	1375	1475	1575	1675	1775	1875	1975	2075	2175	2275	2375	2475	2575	2675	2775	2875	2975	3075	3175	3275	3375	3475	3575
A	200	100	200	100	200	100	200	100	200	100	200	100	200	100	200	100	200	100	200	100	200	100	200	100	200	100	200	100	200	100
N	6	8	8	10	10	12	12	14	14	16	16	18	18	20	20	22	22	24	24	26	26	28	28	30	30	32	32	34	34	36
M	2	2	3	3	4	4	5	5	6	6	7	7	8	8	9	9	10	10	11	11	12	12	13	13	14	14	15	15	16	16
KG	26.5	28	29.5	31	32.5	34	35.5	37	38.5	40	41.5	43	44.5	46	47.5	49	50.5	52	53.5	55	56.5	58	59.5	61	62.5	64	65.5	67	68.5	70

如有超长行程及定制需求,请咨询我司业务。If you have extra long trip and custom requirements, please consult our business.

LU 电机外置左上 Motor external upper left

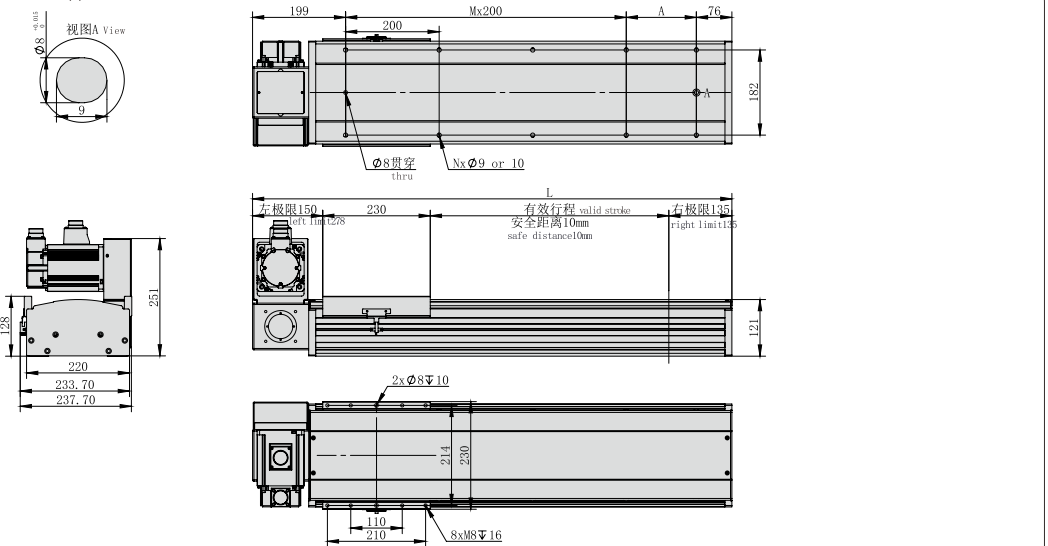

\*不含电机重量。\*Motor weight not included.

有效行程 Stroke	150	250	350	450	550	650	750	850	950	1050	1150	1250	1350	1450	1550	1650	1750	1850	1950	2050	2150	2250	2350	2450	2550	2650	2750	2850	2950	3050
L	675	775	875	975	1075	1175	1275	1375	1475	1575	1675	1775	1875	1975	2075	2175	2275	2375	2475	2575	2675	2775	2875	2975	3075	3175	3275	3375	3475	3575
A	200	100	200	100	200	100	200	100	200	100	200	100	200	100	200	100	200	100	200	100	200	100	200	100	200	100	200	100	200	100
N	6	8	8	10	10	12	12	14	14	16	16	18	18	20	20	22	22	24	24	26	26	28	28	30	30	32	32	34	34	36
M	2	2	3	3	4	4	5	5	6	6	7	7	8	8	9	9	10	10	11	11	12	12	13	13	14	14	15	15	16	16
KG	26.5	28	29.5	31	32.5	34	35.5	37	38.5	40	41.5	43	44.5	46	47.5	49	50.5	52	53.5	55	56.5	58	59.5	61	62.5	64	65.5	67	68.5	70

如有超长行程及定制需求,请咨询我司业务。If you have extra long trip and custom requirements, please consult our business.

- HNR
- HCR
- HNB
- HCB
- HNT
- XYZ
- ONB
- OCB
- GCR
- GCB
- GCBS
- GCRS
- ESR
- EMR
- EHR
- KSR
- LNP
- DDR

参考资料  
Reference data



电机外置右下/电机外置右上  
Motor external lower right / Motor external upper right

RP 电机外置右下 Motor external lower right

单位:Unit: mm

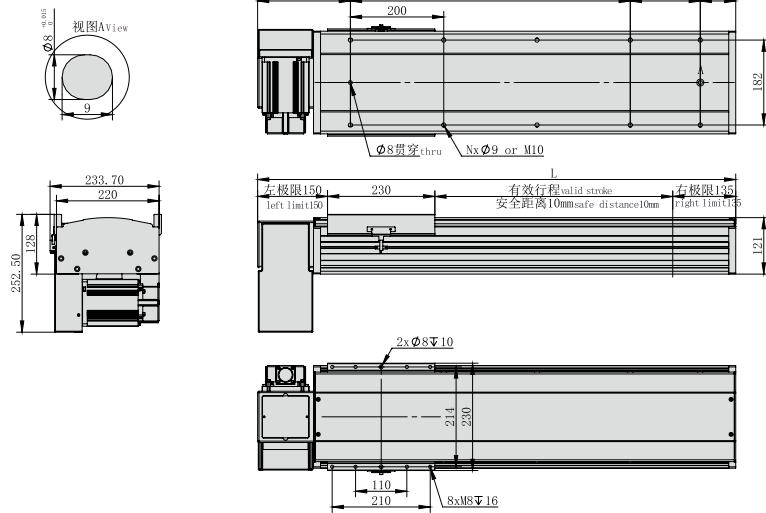

\*不含电机重量。\*Motor weight not included.

有效行程 Stroke	150	250	350	450	550	650	750	850	950	1050	1150	1250	1350	1450	1550	1650	1750	1850	1950	2050	2150	2250	2350	2450	2550	2650	2750	2850	2950	3050
L	675	775	875	975	1075	1175	1275	1375	1475	1575	1675	1775	1875	1975	2075	2175	2275	2375	2475	2575	2675	2775	2875	2975	3075	3175	3275	3375	3475	3575
A	200	100	200	100	200	100	200	100	200	100	200	100	200	100	200	100	200	100	200	100	200	100	200	100	200	100	200	100	200	100
N	6	8	8	10	10	12	12	14	14	16	16	18	18	20	20	22	22	24	24	26	26	28	28	30	30	32	32	34	34	36
M	2	2	3	3	4	4	5	5	6	6	7	7	8	8	9	9	10	10	11	11	12	12	13	13	14	14	15	15	16	16
KG	26.5	28	29.5	31	32.5	34	35.5	37	38.5	40	41.5	43	44.5	46	47.5	49	50.5	52	53.5	55	56.5	58	59.5	61	62.5	64	65.5	67	68.5	70

如有超长行程及定制需求,请咨询我司业务。If you have extra long trip and custom requirements, please consult our business.

RU 电机外置右上 Motor external upper right

单位:Unit: mm

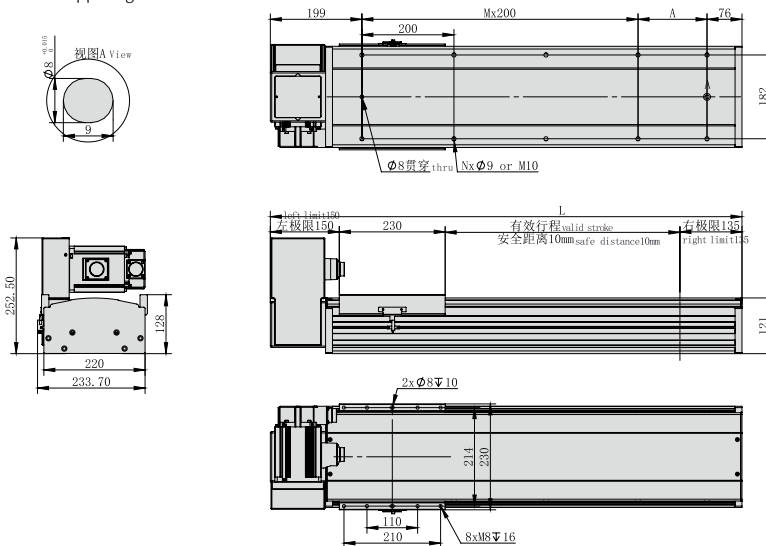

\*不含电机重量。\*Motor weight not included.

有效行程 Stroke	150	250	350	450	550	650	750	850	950	1050	1150	1250	1350	1450	1550	1650	1750	1850	1950	2050	2150	2250	2350	2450	2550	2650	2750	2850	2950	3050
L	675	775	875	975	1075	1175	1275	1375	1475	1575	1675	1775	1875	1975	2075	2175	2275	2375	2475	2575	2675	2775	2875	2975	3075	3175	3275	3375	3475	3575
A	200	100	200	100	200	100	200	100	200	100	200	100	200	100	200	100	200	100	200	100	200	100	200	100	200	100	200	100	200	100
N	6	8	8	10	10	12	12	14	14	16	16	18	18	20	20	22	22	24	24	26	26	28	28	30	30	32	32	34	34	36
M	2	2	3	3	4	4	5	5	6	6	7	7	8	8	9	9	10	10	11	11	12	12	13	13	14	14	15	15	16	16
KG	26.5	28	29.5	31	32.5	34	35.5	37	38.5	40	41.5	43	44.5	46	47.5	49	50.5	52	53.5	55	56.5	58	59.5	61	62.5	64	65.5	67	68.5	70

如有超长行程及定制需求,请咨询我司业务。If you have extra long trip and custom requirements, please consult our business.

MEMO

- HNR
- HCR
- HNB
- HCB
- HNT
- XYZ
- ONB
- OCB
- GCR
- GCB
- GCBS
- GCRS
- ESR
- EMR
- EHR
- KSR
- LNP
- DDR

参考资料  
Reference data



重复精度  
Repeat Accuracy  
±0.04 mm

此图仅供参考, 出货规格详见尺寸图面  
This picture for reference only, specs details according with the drawing.

最大行程  
Max stroke 3050mm

最高速度  
Max speed 7000mm/s

马达容量  
Motor output 1000W

直线导轨  
Linear guide 23X22-2支

型号表达方式 Ordering method

TPA-HNB-270D-140-L3050-MR-Y-P1K-N3-F

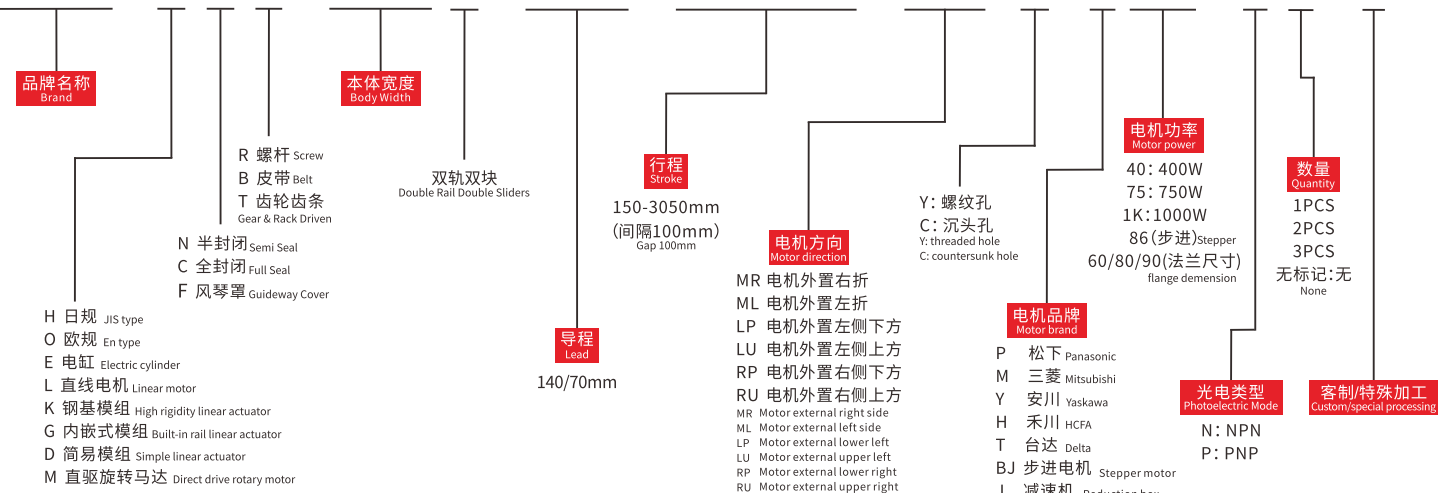

产品性能参数如下 Product performance parameters are as follows

规格 Spec	电机功率 (W) Motor power (W)	1000	
	重复定位精度 (mm) Repeated positioning accuracy (mm)	±0.04	
	减速比 (mm) Reduction ratio	1:1	1:2
	导程 (mm) Lead (mm)	140	70
	最高速度 (mm/s) Maximum speed (mm/s)	7000	
	电机额定转速 (RPM) Rated speed of motor (RPM)	3000	
最大可搬重量 Maximum Payload	70	140	
	标准行程 (mm) Stroke pitch (mm)	150~3050mm/100 间隔100 mm Pitch	
部品 Parts	底座材质 Material of base	硬质挤压铝材A1 Hard extruded aluminum A1	
	使用环境 Operating environment	0~40°C, 85%RH (无凝结) No condensation	

注1: 使用非上述功率电机时请依据实际参数推算。  
Note 1: When using a motor with a power other than the above, please calculate according to the actual parameters.

注2: 最高速度因行程和负载而异, 当螺杆细长比大于1:50时, 可能会因螺杆临界速度产生共振和抖动, 应适当下调运行速度, 一般螺杆每增长100mm, 速度应下调10~15%。  
Note 2: The maximum speed varies with stroke and load. When the screw slenderness ratio is greater than 1:50, resonance and jitter may occur due to the critical speed of the screw, so the running speed should be reduced appropriately. Generally, the speed should be reduced by 10~15% for every 100mm increase of the screw.

容许负载力矩表 N.m Allowable overhang

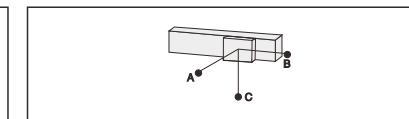
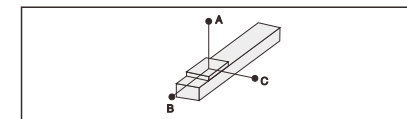

		(单位Unit:mm)			(单位Unit:mm)			
		水平安装 Horizontal installation			侧面安装 Side mounting			
		A	B	C	A	B	C	
负载 Load	90kg	1579	605	336	90kg	485	682	1783
	115kg	1136	328	283	115kg	318	420	1136
	140kg	771	269	210	140kg	205	281	772

传感器连接图<原点及端点> Sensor layout

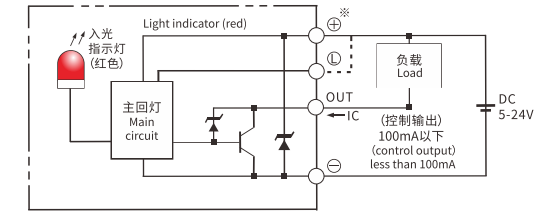

- HNR
- HCR
- HNB
- HCB
- HNT
- XYZ
- ONB
- OCB
- GCR
- GCB
- GCBS
- GCRS
- ESR
- EMR
- EHR
- KSR
- LNP
- DDR
- 参考资料  
Reference data

静态容许负载惯量 Static loading moment

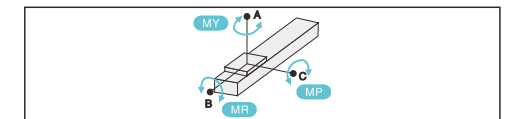

		(单位Unit:N.m)
MY		3223
MP		3223
MR		2843

\*力矩表所表示的数据, 代表重心。  
The torque value in the chart indicate the center of gravity.  
\*符合型录规范的正常试用下, 保证寿命为10000公里。  
Operation life is 10,000km when the product is using under the specified conditions.  
\*倒吊使用无法套用标准规范, 如有需求请咨询我司业务。  
The standard specification cannot be applied to the use of inverted crane. Please consult our business if necessary.

搭配伺服马达一览表 Suitable motor brand

品牌 Brand	马达记号 Mark	刹车有无 Brake	马达容量 Motor capacity	电源电压 AC-Voltage	伺服马达型号 Servo motor model	驱动器型号 Driver Model
三菱 Mitsubishi	M	无刹车(水平式样) No brake (horizontal type)	200	220	HG-KR73	MR-J4-70A
松下 Panasonic	P	无刹车(水平式样) No brake (horizontal type)	200	220	MHMD082G1U	MBDHT3520
台达 Delta	T	无刹车(水平式样) No brake (horizontal type)	200	220	ECMA-C20807ES	ASD-B20721-B



电机外置左侧/电机外置右侧  
Motor external left side / Motor external right side

**ML** 电机外置左侧 Motor external left side

单位:Unit: mm

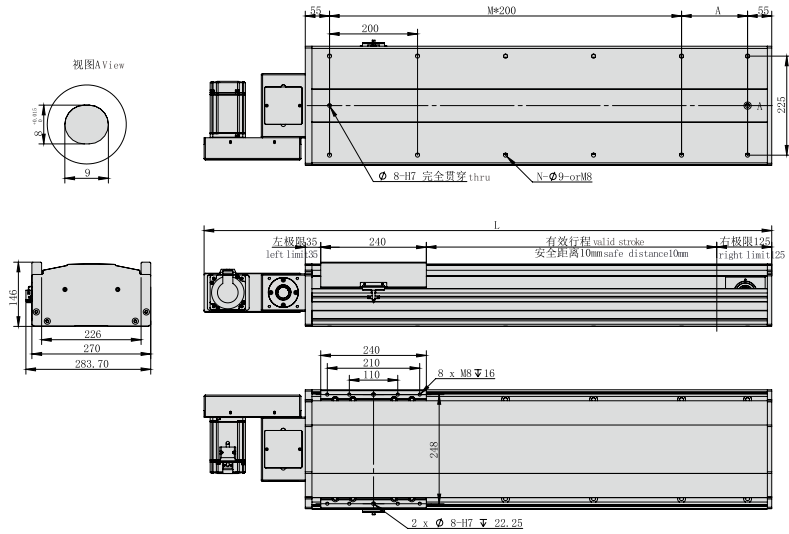

\*不含电机重量。\*Motor weight not included.

有效行程 Stroke	150	250	350	450	550	650	750	850	950	1050	1150	1250	1350	1450	1550	1650	1750	1850	1950	2050	2150	2250	2350	2450	2550	2650	2750	2850	2950	3050
L	790	890	990	1090	1190	1290	1390	1490	1590	1690	1790	1890	1990	2090	2190	2290	2390	2490	2590	2690	2790	2890	2990	3090	3190	3290	3390	3490	3590	3690
A	50	150	50	150	50	150	50	150	50	150	50	150	50	150	50	150	50	150	50	150	50	150	50	150	50	150	50	150	50	150
N	8	8	10	10	12	12	14	14	16	16	18	18	20	20	22	22	24	24	26	26	28	28	30	30	32	32	34	34	36	36
M	2	2	3	3	4	4	5	5	6	6	7	7	8	8	9	9	10	10	11	11	12	12	13	13	14	14	15	15	16	16
KG	37	39.2	41.4	43.6	45.8	48	50.2	52.4	54.6	56.8	59	61.2	63.4	65.6	67.8	70	72.2	74.4	76.6	78.8	81	83.2	85.4	87.6	89.8	92	94.2	96.4	98.6	100.8

如有超长行程及定制需求,请咨询我司业务。If you have extra long trip and custom requirements, please consult our business.

电机外置左下/电机外置左上  
Motor external lower left / Motor external upper left

**LP** 电机外置左下 Motor external lower left

单位:Unit: mm

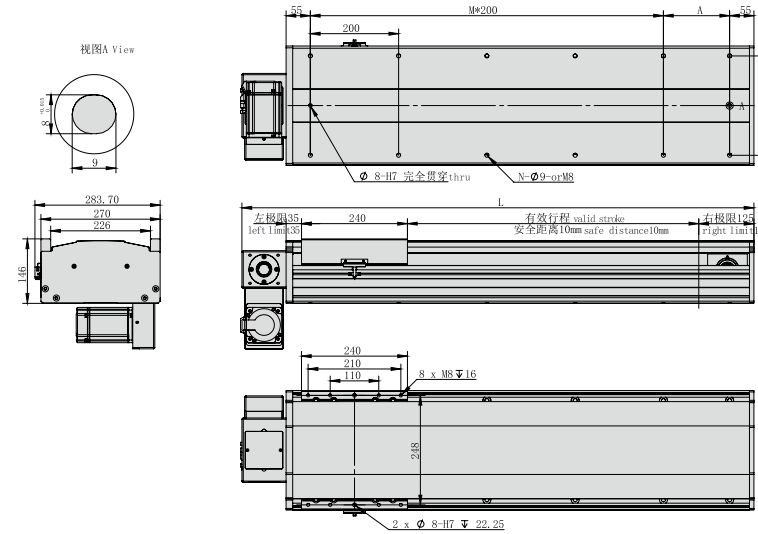

\*不含电机重量。\*Motor weight not included.

有效行程 Stroke	150	250	350	450	550	650	750	850	950	1050	1150	1250	1350	1450	1550	1650	1750	1850	1950	2050	2150	2250	2350	2450	2550	2650	2750	2850	2950	3050
L	660	760	860	960	1060	1160	1260	1360	1460	1560	1660	1760	1860	1960	2060	2160	2260	2360	2460	2560	2660	2760	2860	2960	3060	3160	3260	3360	3460	3560
A	50	150	50	150	50	150	50	150	50	150	50	150	50	150	50	150	50	150	50	150	50	150	50	150	50	150	50	150	50	150
N	8	8	10	10	12	12	14	14	16	16	18	18	20	20	22	22	24	24	26	26	28	28	30	30	32	32	34	34	36	36
M	2	2	3	3	4	4	5	5	6	6	7	7	8	8	9	9	10	10	11	11	12	12	13	13	14	14	15	15	16	16
KG	37	39.2	41.4	43.6	45.8	48	50.2	52.4	54.6	56.8	59	61.2	63.4	65.6	67.8	70	72.2	74.4	76.6	78.8	81	83.2	85.4	87.6	89.8	92	94.2	96.4	98.6	100.8

如有超长行程及定制需求,请咨询我司业务。If you have extra long trip and custom requirements, please consult our business.

**MR** 电机外置右侧 Motor external right side

单位:Unit: mm

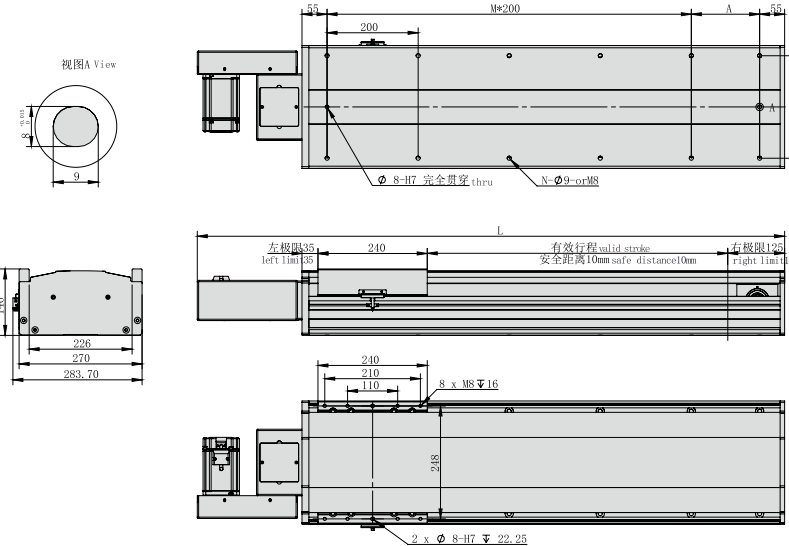

\*不含电机重量。\*Motor weight not included.

有效行程 Stroke	150	250	350	450	550	650	750	850	950	1050	1150	1250	1350	1450	1550	1650	1750	1850	1950	2050	2150	2250	2350	2450	2550	2650	2750	2850	2950	3050
L	790	890	990	1090	1190	1290	1390	1490	1590	1690	1790	1890	1990	2090	2190	2290	2390	2490	2590	2690	2790	2890	2990	3090	3190	3290	3390	3490	3590	3690
A	50	150	50	150	50	150	50	150	50	150	50	150	50	150	50	150	50	150	50	150	50	150	50	150	50	150	50	150	50	150
N	8	8	10	10	12	12	14	14	16	16	18	18	20	20	22	22	24	24	26	26	28	28	30	30	32	32	34	34	36	36
M	2	2	3	3	4	4	5	5	6	6	7	7	8	8	9	9	10	10	11	11	12	12	13	13	14	14	15	15	16	16
KG	37	39.2	41.4	43.6	45.8	48	50.2	52.4	54.6	56.8	59	61.2	63.4	65.6	67.8	70	72.2	74.4	76.6	78.8	81	83.2	85.4	87.6	89.8	92	94.2	96.4	98.6	100.8

如有超长行程及定制需求,请咨询我司业务。If you have extra long trip and custom requirements, please consult our business.

**LU** 电机外置左上 Motor external upper left

单位:Unit: mm

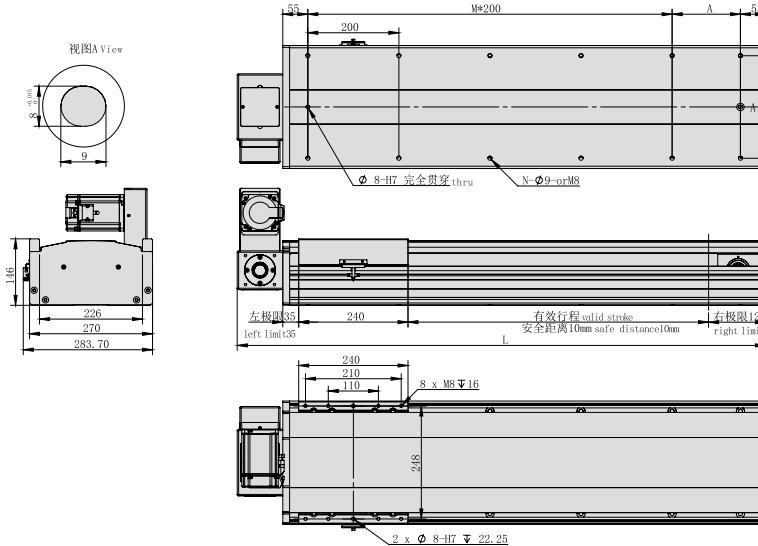

\*不含电机重量。\*Motor weight not included.

有效行程 Stroke	150	250	350	450	550	650	750	850	950	1050	1150	1250	1350	1450	1550	1650	1750	1850	1950	2050	2150	2250	2350	2450	2550	2650	2750	2850	2950	3050
L	660	760	860	960	1060	1160	1260	1360	1460	1560	1660	1760	1860	1960	2060	2160	2260	2360	2460	2560	2660	2760	2860	2960	3060	3160	3260	3360	3460	3560
A	50	150	50	150	50	150	50	150	50	150	50	150	50	150	50	150	50	150	50	150	50	150	50	150	50	150	50	150	50	150
N	8	8	10	10	12	12	14	14	16	16	18	18	20	20	22	22	24	24	26	26	28	28	30	30	32	32	34	34	36	36
M	2	2	3	3	4	4	5	5	6	6	7	7	8	8	9	9	10	10	11	11	12	12	13	13	14	14	15	15	16	16
KG	37	39.2	41.4	43.6	45.8	48	50.2	52.4	54.6	56.8	59	61.2	63.4	65.6	67.8	70	72.2	74.4	76.6	78.8	81	83.2	85.4	87.6	89.8	92	94.2	96.4	98.6	100.8

如有超长行程及定制需求,请咨询我司业务。If you have extra long trip and custom requirements, please consult our business.

- HNR
- HCR
- HNB
- HCB
- HNT
- XYZ
- ONB
- OCB
- GCR
- GCB
- GCBS
- GCRS
- ESR
- EMR
- EHR
- KSR
- LNP
- DDR

参考资料  
Reference data





电机外置右下/电机外置右上  
Motor external lower right / Motor external upper right

RP 电机外置右下 Motor external lower right

单位:Unit: mm

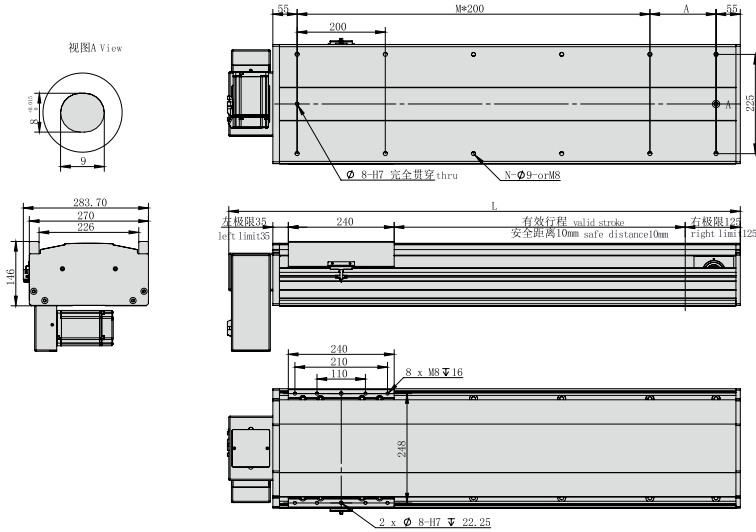

\*不含电机重量。\*Motor weight not included.

有效行程 Stroke	150	250	350	450	550	650	750	850	950	1050	1150	1250	1350	1450	1550	1650	1750	1850	1950	2050	2150	2250	2350	2450	2550	2650	2750	2850	2950	3050
L	660	760	860	960	1060	1160	1260	1360	1460	1560	1660	1760	1860	1960	2060	2160	2260	2360	2460	2560	2660	2760	2860	2960	3060	3160	3260	3360	3460	3560
A	50	150	50	150	50	150	50	150	50	150	50	150	50	150	50	150	50	150	50	150	50	150	50	150	50	150	50	150	50	150
N	8	8	10	10	12	12	14	14	16	16	18	18	20	20	22	22	24	24	26	26	28	28	30	30	32	32	34	34	36	36
M	2	2	3	3	4	4	5	5	6	6	7	7	8	8	9	9	10	10	11	11	12	12	13	13	14	14	15	15	16	16
KG	37	39.2	41.4	43.6	45.8	48	50.2	52.4	54.6	56.8	59	61.2	63.4	65.6	67.8	70	72.2	74.4	76.6	78.8	81	83.2	85.4	87.6	89.8	92	94.2	96.4	98.6	100.8

如有超长行程及定制需求,请咨询我司业务。If you have extra long trip and custom requirements, please consult our business.

RU 电机外置右上 Motor external upper right

单位:Unit: mm

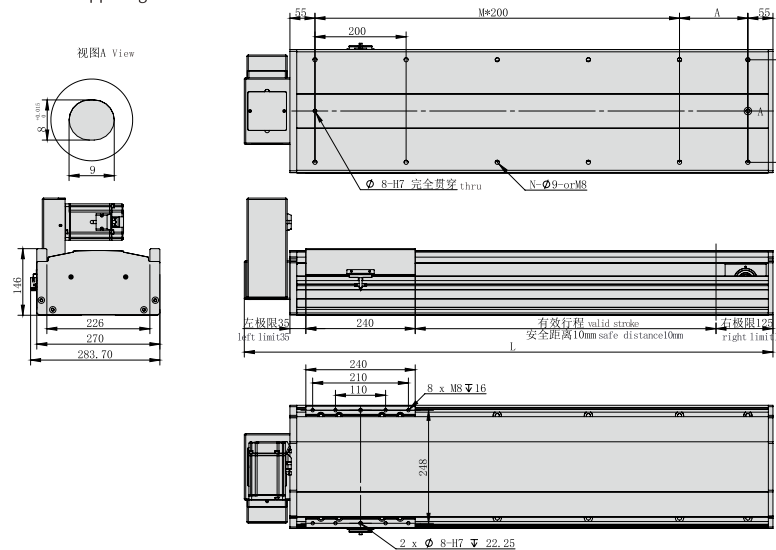

\*不含电机重量。\*Motor weight not included.

有效行程 Stroke	150	250	350	450	550	650	750	850	950	1050	1150	1250	1350	1450	1550	1650	1750	1850	1950	2050	2150	2250	2350	2450	2550	2650	2750	2850	2950	3050
L	660	760	860	960	1060	1160	1260	1360	1460	1560	1660	1760	1860	1960	2060	2160	2260	2360	2460	2560	2660	2760	2860	2960	3060	3160	3260	3360	3460	3560
A	50	150	50	150	50	150	50	150	50	150	50	150	50	150	50	150	50	150	50	150	50	150	50	150	50	150	50	150	50	150
N	8	8	10	10	12	12	14	14	16	16	18	18	20	20	22	22	24	24	26	26	28	28	30	30	32	32	34	34	36	36
M	2	2	3	3	4	4	5	5	6	6	7	7	8	8	9	9	10	10	11	11	12	12	13	13	14	14	15	15	16	16
KG	37	39.2	41.4	43.6	45.8	48	50.2	52.4	54.6	56.8	59	61.2	63.4	65.6	67.8	70	72.2	74.4	76.6	78.8	81	83.2	85.4	87.6	89.8	92	94.2	96.4	98.6	100.8

如有超长行程及定制需求,请咨询我司业务。If you have extra long trip and custom requirements, please consult our business.

MEMO

HNR

HCR

HNB

HCB

HNT

XYZ

ONB

OCB

GCR

GCB

GCBS

GCRS

ESR

EMR

EHR

KSR

LNP

DDR

参考资料

Reference

data